

DF40F Series

Small Floating Board-to-Board Connector, 125°C Heat Resistance for Automotive



Compact



Floating



High Temp

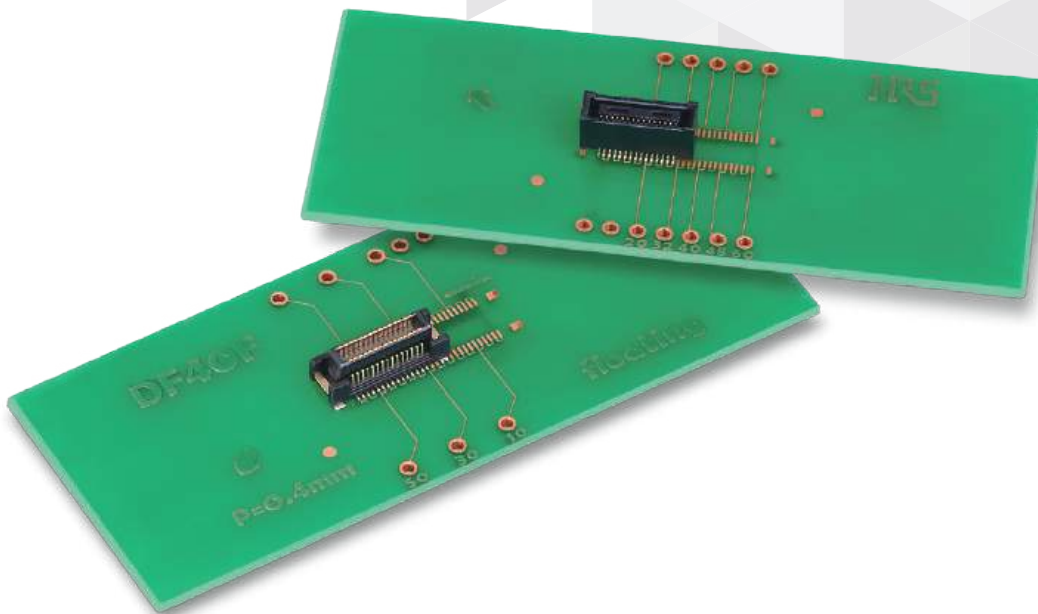

NEW



Features

1. 0.4mm Pitch, 3.68mm Width, Stacking Height 3.5 to 6.0mm World's Smallest Width Class in Floating Board-to-Board Connectors

It contributes to making board design space-saving. Significantly reduces the area occupied on mounting part.

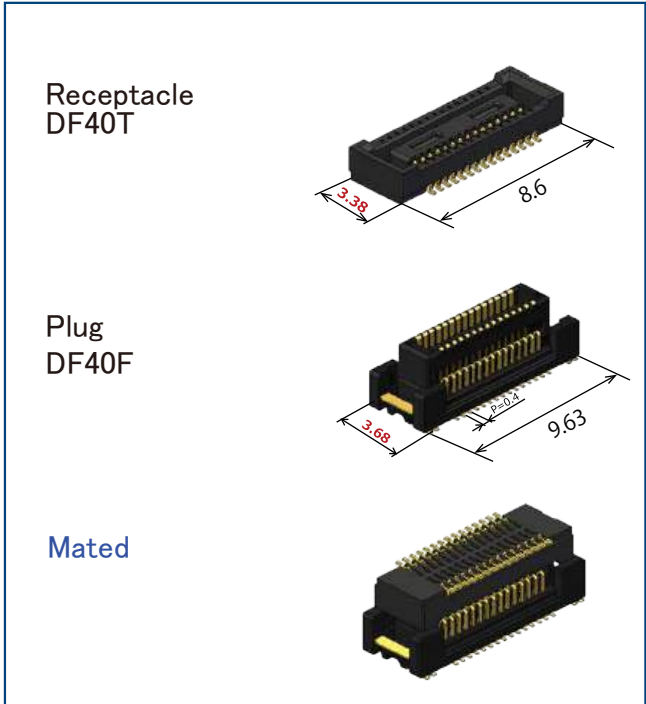

Small & Space-Saving (e.g. 30pos.)

2. Absorption of Misalignment

X and Y Directions :
Floating Range $\pm 0.3\text{mm}$

Z Direction :
Effective Mating Length
 $\pm 0.25/0\text{mm}$

The board mounting misalignment and misalignment due to board warpage can be absorbed by the connector.

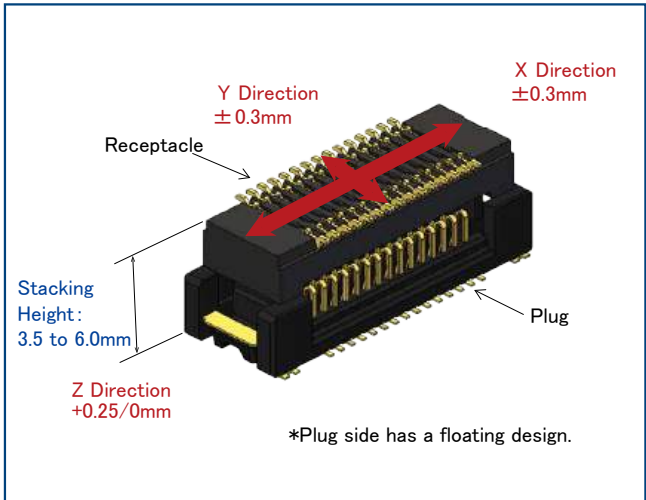

Large Floating Range & Effective Mating Length

Mar.1.2026 Copyright 2026 HIROSE ELECTRIC CO., LTD. All Rights Reserved.

3. Wide Variety of Stacking Heights by Mating Combination with DF40T

Plug DF40F and Receptacle DF40T are used in combination.

Stacking Height can be changed by changing receptacle side.

- DF40F : 1 Type
- DF40T : 6 Types

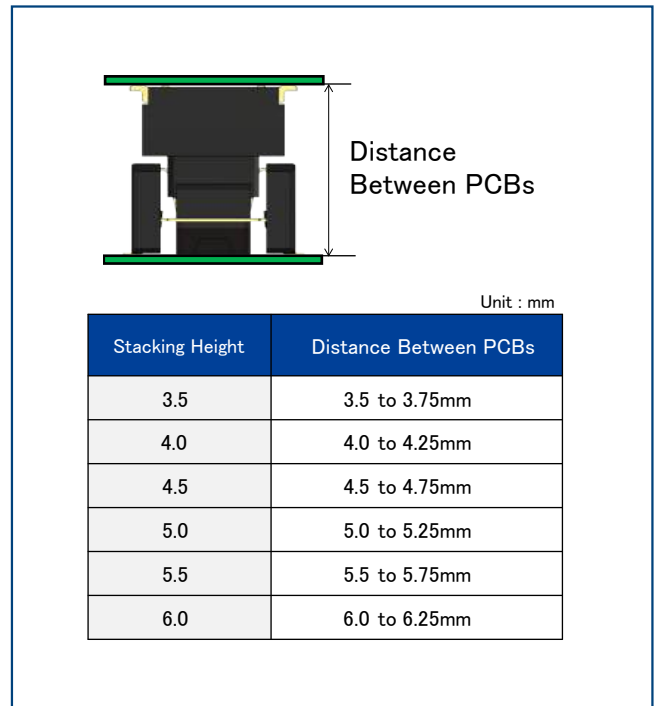

Stacking Height Variation

4. 125°C Heat Resistance for Automotive Specifications

5. Supports High Speed Transmission

All heights support these standards.

PCI-ex Gen.4 (16Gbps)

- Pin Assign : GGGSSGSSGGG
- Reference Impedance : 85Ω

MIPI D-PHY Ver. 1.1 (1.5Gbps)

- Pin Assign : GGSGSGSGSGG
- Reference Impedance : 100Ω

Applications

It can be used for in-vehicle applications for front cameras, Rear/Side Cameras, Millimeter-Wave Radar LiDAR and other devices that require misalignment absorption of the substrate by small size floating. It can also be used in devices that require absorption of the substrate misalignment for consumer and industrial equipment.

Product Specifications

Rated Current	0.3A	Operating Temperature (Note 1)(Note 2)	-55 to +125°C
Rated Voltage	30V AC/DC	Storage Temperature (Note 3)	-10 to +60°C

Item	Specifications	Conditions
Contact Resistance	90m Ω Max.	Measured at 20mV AC, 1kHz, 1mA
Insulation Resistance	50M Ω Min.	Measured at 100V DC
Withstanding Voltage	No Flashover or Breakdown	100V AC for 1 min.
Mating Durability	Contact Resistance : 90m Ω Max. No damage, cracks or part dislocation.	10 times
Vibration Resistance	There should be no electrical interruption of 1 μ s Min. No damage, cracks or part dislocation.	Frequency 10 to 500Hz, Acceleration 49m/s ² Swept speed 1oct/min 8 hours each of 3-axis direction
Heat Resistance	Contact Resistance : 90m Ω Max. No damage, cracks or part dislocation.	Left for 1000 hours at Temperature 125 ± 2°C
Moisture Resistance	Contact Resistance : 90m Ω Max. Insulation Resistance : 25M Ω Min. No damage, cracks or part dislocation.	Temperature -10 → +65°C , RH In 90 - 96% Left for 10 cycles (240 hours)
Temperature Cycles	Contact Resistance : 90m Ω Max. No damage, cracks or part dislocation.	Temperature -55°C : 30min. → +125°C : 30min., 1000 cycles (Tank transfer time : 2 to 3min.)
Solder Heat Resistance	No deformation in appearance or significant damage to contacts.	Reflow : According to the Recommended Temperature Profile Hand Soldering : 350°C within 3 sec.

Note 1 : Includes the temperature rise due to current flow.

Note 2 : Use without condensation.

Note 3 : Storage refers to long-term storage of unused items before they are mounted on the PCB.

Operating temperature and humidity range apply when the product is not powered after PCB mounting and when temporarily stored during transportation.

Materials/Finish

Item	Component	Material	Color/Finish
Plug DF40F	Insulator	LCP	Black
	Contact	Copper Alloy	Gold Plating (Nickle Underplating)
	Retention Tab	Copper Alloy	Gold Plating (Nickle Underplating)
Receptacle DF40T	Insulator	LCP	Black
	Contact	Copper Alloy	Gold Plating (Nickle Underplating)

Product Number Structure

Refer to the chart below when determining the product specifications from the product number.
Please select from the product numbers listed in this catalog when placing orders.

■ Plug

DF40 F (2.0) - 30 DP - 0.4 V (51)

① ② ③ ④ ⑤ ⑥ ⑦ ⑧

■ Receptacle

DF40 TC (4.0) - 30 DS - 0.4 V (51)

① ② ③ ④ ⑤ ⑥ ⑦ ⑧

① Series Name	DF40	⑤ Connector Type	DP : Double Row Plug DS : Double Row Receptacle
② Shape Symbol	F : Floating TC : No Retention Tab	⑥ Contact Pitch	0.4mm
③ Stacking Height	3.5, 4.0, 4.5, 5.0, 5.5, 6.0 mm Stacking Height is total value of (a) and (b) below. Plug (a) : 2.0 Receptacle (b) : 1.5, 2.0, 2.5, 3.0, 3.5, 4.0 (Note 1)	⑦ Contact Type	V : Straight SMT
		⑧ Packaging Type	(51) : Embossed Tape Packaging, DF40F 3,000pcs/reel DF40TC 5,000pcs/reel DF40TC(2.5) 3,000pcs/reel DF40TC(3.0) 3,000pcs/reel DF40TC(3.5) 2,000pcs/reel DF40TC(4.0) 2,000pcs/reel
④ No. of Pos.	30		(53) : Embossed Tape Packaging, 500pcs/reel (For trial production)

Note 1 : (1.5) of the Receptacle will be blank. (e.g. : DF40TC-30DS-0.4V(51))

Combinations

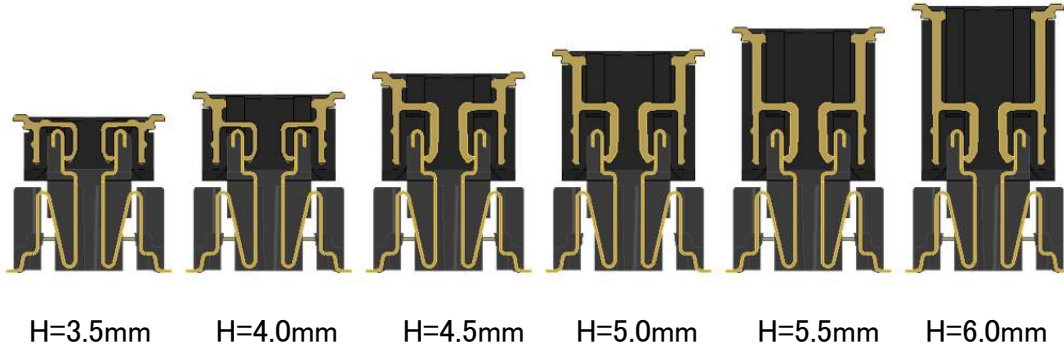

Unit : mm

Receptacle/Plug	DF40F(2.0)-30DP-0.4V(##) Stacking Height
DF40TC-30DS-0.4V(##)	3.5
DF40TC(2.0)-30DS-0.4V(##)	4.0
DF40TC(2.5)-30DS-0.4V(##)	4.5
DF40TC(3.0)-30DS-0.4V(##)	5.0
DF40TC(3.5)-30DS-0.4V(##)	5.5
DF40TC(4.0)-30DS-0.4V(##)	6.0

DF40F (125°C Heat Resistant Floating Type) Plug

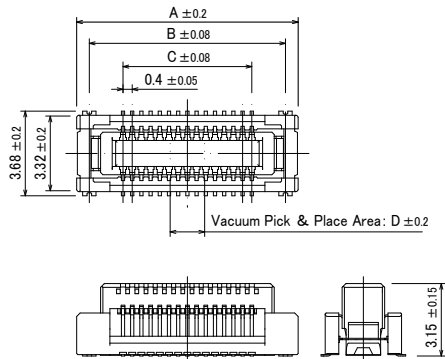

● Recommended PCB Layout

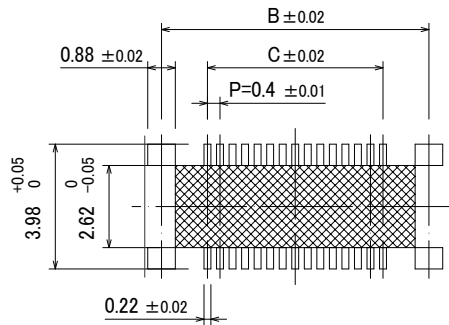

▨ Pattern Prohibited Area

● Recommended Metal Mask Dimensions

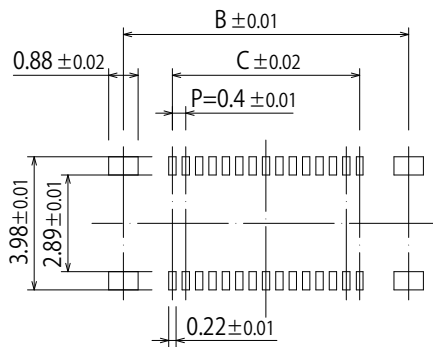

Recommended Metal Mask Thickness : 0.12mm, Open Area Ratio : 80%

Unit : mm

Part No.	HRS No.	No. of Pos.	A	B	C	D	Purchase Unit (##) : (51)	Purchase Unit (##) : (53)
DF40F(2.0)-30DP-0.4V(##)	CL0684-4501-0-##	30	9.63	8.53	5.6	1.5	3,000pcs per reel	500pcs per reel

Note : This connector has no polarity.

DF40T (125°C Heat Resistant Standard Type) Receptacle (Stacking Height 3.5mm)

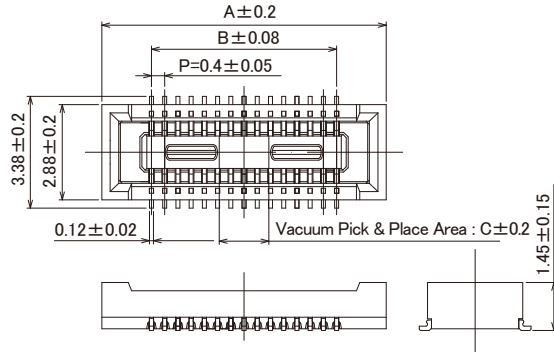

Recommended PCB Layout

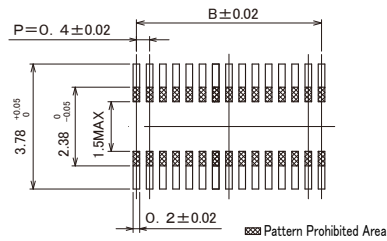

Recommended Metal Mask Thickness : 0.12mm, Open Area Ratio : 80%

Unit : mm

Part No.	HRS No.	No. of Pos.	A	B	C	Purchase Unit (##) : (51)	Purchase Unit (##) : (53)
DF40TC-30DS-0.4V(##)	CL0684-4261-0-##	30	8.6	5.6	1.5	5,000pcs per reel	500pcs per reel

Note : This connector has no polarity.

DF40T (125°C Heat Resistant Standard Type) Receptacle (Stacking Height 4.0mm)

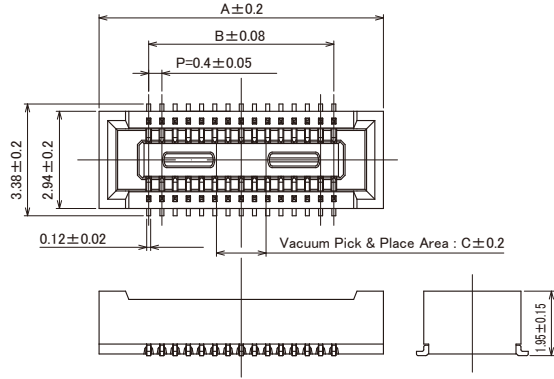

● **Recommended PCB Layout**

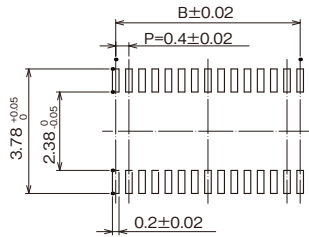

Recommended Metal Mask Thickness : 0.12mm, Open Area Ratio : 80%

Unit : mm

Part No.	HRS No.	No. of Pos.	A	B	C	Purchase Unit (##) : (51)	Purchase Unit (##) : (53)
DF40TC(2.0)-30DS-0.4V(##)	CL0684-4265-0-##	30	8.6	5.6	1.5	4,000pcs per reel	500pcs per reel

Note : This connector has no polarity.

DF40T (125°C Heat Resistant Standard Type) Receptacle (Stacking Height 4.5 to 6.0mm)

● **Stacking Height 4.5mm**

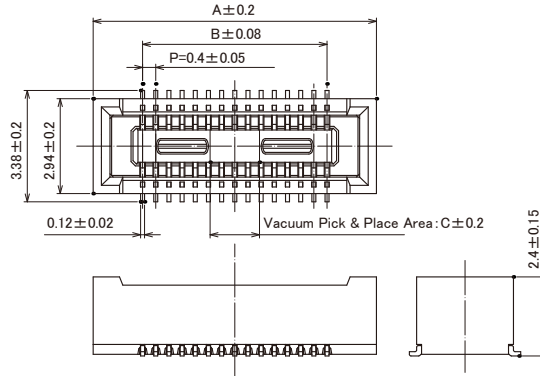

● **Recommended PCB Layout**

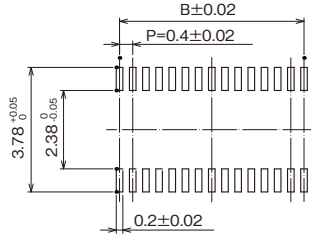

Recommended Metal Mask Thickness : 0.12mm, Open Area Ratio : 80%

Unit : mm

Part No.	HRS No.	No. of Pos.	A	B	C	Purchase Unit (##) : (51)	Purchase Unit (##) : (53)
DF40TC(2.5)-30DS-0.4V(##)	CL0684-4266-0-##	30	8.6	5.6	1.5	3,000pcs per reel	500pcs per reel

Note : This connector has no polarity.

● Stacking Height 5.0mm

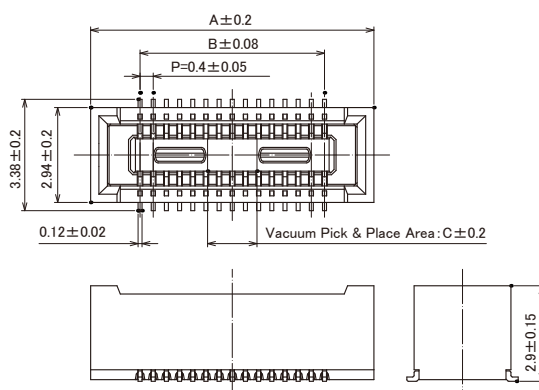

● Recommended PCB Layout

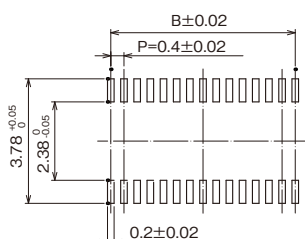

Recommended Metal Mask Thickness : 0.12mm. Open Area Ratio : 80%

Unit : mm

Part No.	HRS No.	No. of Pos.	A	B	C	Purchase Unit (##) : (51)	Purchase Unit (##) : (53)
DF40TC(3.0)-30DS-0.4V(##)	CL0684-4242-0-##	30	8.6	5.6	1.5	3,000pcs per reel	500pcs per reel

Note : This connector has no polarity.

● Stacking Height 5.5mm

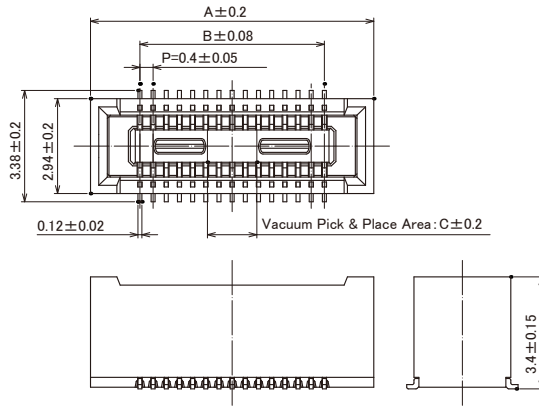
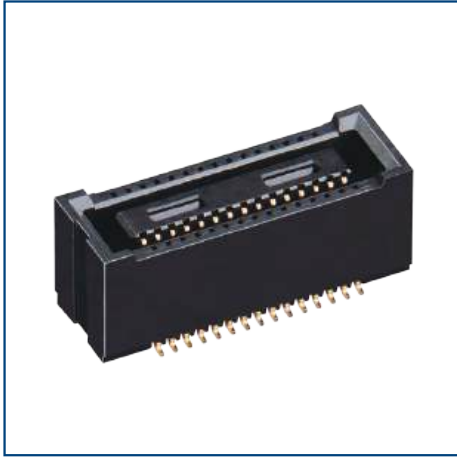

● Recommended PCB Layout

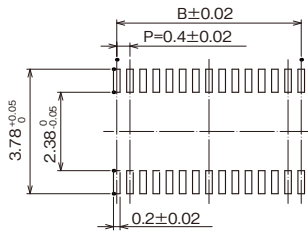

Recommended Metal Mask Thickness : 0.12mm, Open Area Ratio : 80%

Unit : mm

Part No.	HRS No.	No. of Pos.	A	B	C	Purchase Unit (##) : (51)	Purchase Unit (##) : (53)
DF40TC(3.5)-30DS-0.4V(##)	CL0684-4237-0-##	30	8.6	5.6	1.5	2,000pcs per reel	500pcs per reel

Note : This connector has no polarity.

● Stacking Height 6.0mm

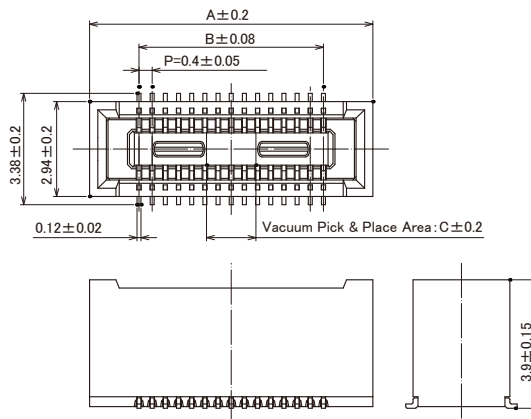

● Recommended PCB Layout

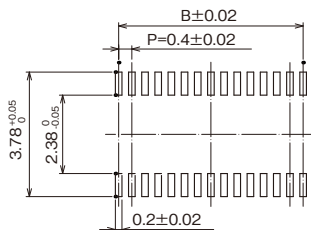

Recommended Metal Mask Thickness : 0.12mm, Open Area Ratio : 80%

Unit : mm

Part No.	HRS No.	No. of Pos.	A	B	C	Purchase Unit (##) : (51)	Purchase Unit (##) : (53)
DF40TC(4.0)-30DS-0.4V(##)	CL0684-4256-0-##	30	8.6	5.6	1.5	2,000pcs per reel	500pcs per reel

Note : This connector has no polarity.

Packaging Specifications Diagram (JIS C 0806, IEC 60286-3 Compliant)

DF40F Plug

Embossed Carrier Tape Dimensions

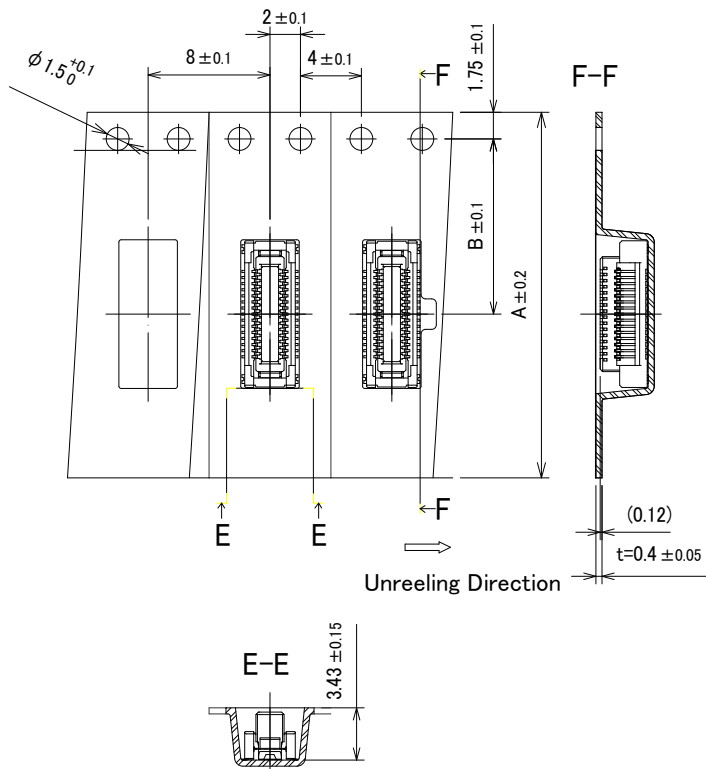

Reel Dimensions

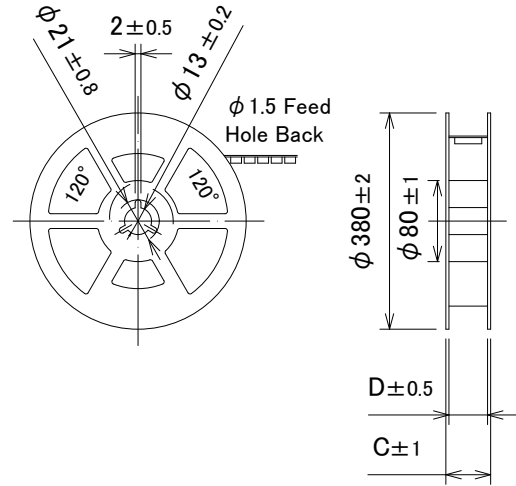

Unit : mm

Part No.	HRS No.	A	B	C	D	Purchase Unit (##) : (51)	Purchase Unit (##) : (53)
DF40F(2.0)-30DP-0.4V(##)	CL0684-4501-0-##	24	11.5	29.5	25.5	3,000pcs per reel	500pcs per reel

DF40T Receptacle

- Stacking Height 3.5 to 5.0mm

Embossed Carrier Tape Dimensions

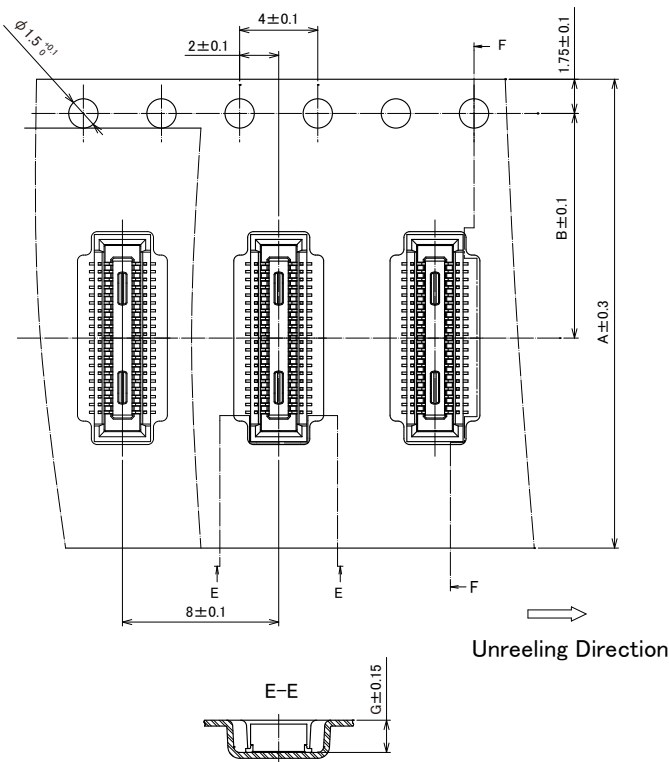

Reel Dimensions

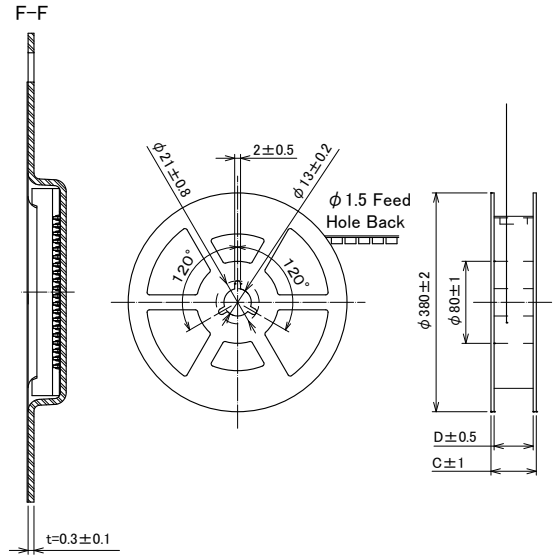

Unit : mm

Part No.	HRS No.	A	B	C	D	G	Purchase Unit (##) : (51)	Purchase Unit (##) : (53)
DF40TC-30DS-0.4V(##)	CL0684-4261-0-##	24	11.5	29.5	25.5	1.65	5,000pcs per reel	500pcs per reel
DF40TC(2.0)-30DS-0.4V(##)	CL0684-4265-0-##	24	11.5	29.5	25.5	2.2	4,000pcs per reel	500pcs per reel
DF40TC(2.5)-30DS-0.4V(##)	CL0684-4266-0-##	24	11.5	29.5	25.5	2.72	3,000pcs per reel	500pcs per reel
DF40TC(3.0)-30DS-0.4V(##)	CL0684-4242-0-##	24	11.5	29.5	25.5	3.15		

● Stacking Height 5.5 to 6.0mm

Embossed Carrier Tape Dimensions

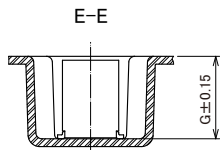
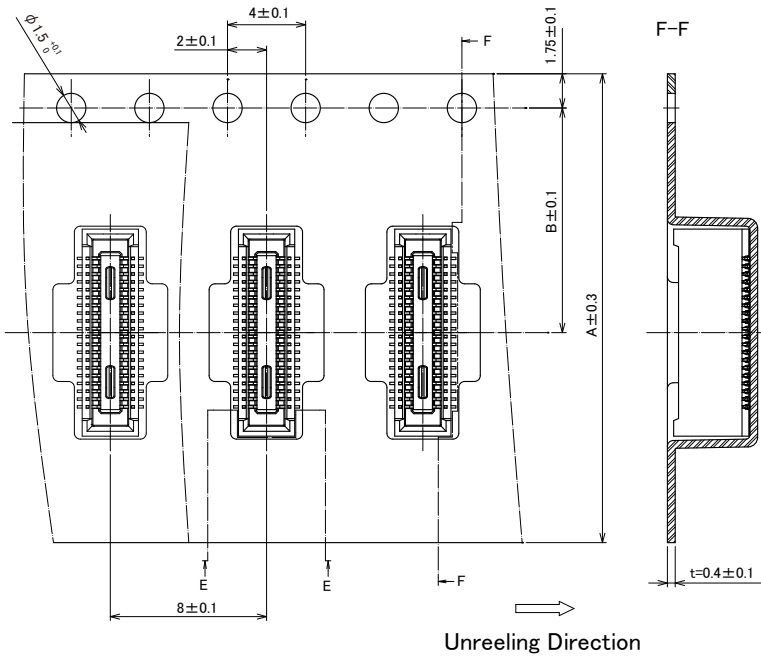

Reel Dimensions

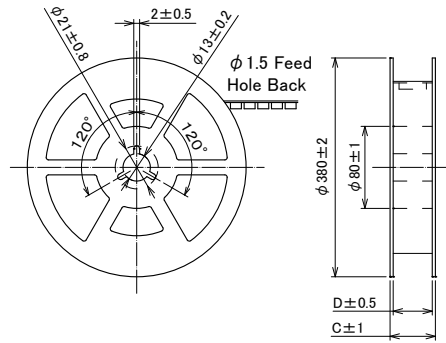

Unit : mm

Part No.	HRS No.	A	B	C	D	G	Purchase Unit (##) : (51)	Purchase Unit (##) : (53)
DF40TC(3.5)-30DS-0.4V(##)	CL0684-4237-0-##	24	11.5	29.5	25.5	3.72	2,000pcs per reel	500pcs per reel
DF40TC(4.0)-30DS-0.4V(##)	CL0684-4256-0-##	24	11.5	29.5	25.5	4.22		

Precautions

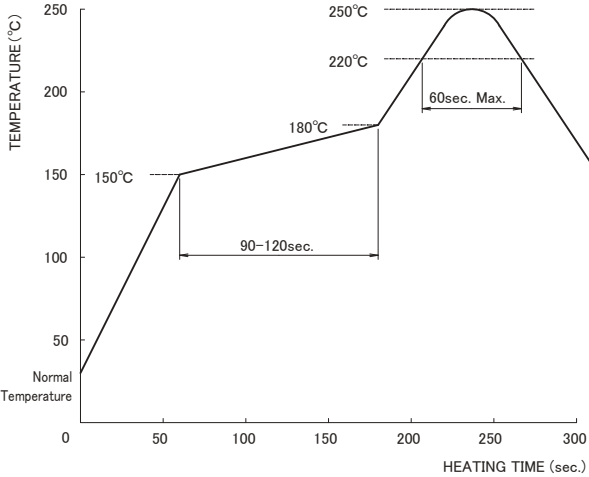
<p>Recommended Temperature Profile</p>	 <p>【Conditions】</p> <ol style="list-style-type: none"> 1. Peak Temperature : 250°C 2. Heating : 220°C Min. for 60 sec. Max. 3. Preheating : 150 to 180°C, 90 to 120 sec. 4. Number of Reflow Cycles : 2 cycles Max. <p>* Temperature refers to the surface temperature of the board near the connector lead. We recommend reflow mounting in a nitrogen environment.</p>
<p>Recommended Manual Soldering Conditions</p>	<p>Soldering iron temperature : 340 ± 10°C , Soldering Time : Within 3 sec.</p>
<p>Recommended Metal Mask Thickness and Open Area to PCB Pattern (Area Ratio)</p>	<p>Thickness : 0.12mm, Aperture Ratio : Plug 80% / Receptacle 80%</p>
<p>Board Warpage</p>	<p>Max. of 0.02mm at the center in reference to both ends of the connector</p>
<p>Cleaning</p>	<p>Cleaning is not recommended. If you clean this product, please evaluate its performance before using it. (Cleaning may impair the mating/unmating properties and lower resistance to environmental factors.)</p>
<p>Precautions</p>	<ul style="list-style-type: none"> · Be careful when mating/unmating the connector when it is not mounted on the PCB as it may cause damage/deformation to contacts. · Avoid supporting the PCB only with the connectors. Support it by other means such as bolts, screws, posts, etc. · Excessive prying during unmating/mating may result in damage. · In the case of hand soldering, please do not apply any flux which could cause flux wicking. · This product may have slight color differences due to production lot variability, but this does not affect the performance. · Please refer to the following page for handling precautions when inserting and removing. · Because the product can disengage if dropped (or other impact), or by FPC routing, it is advised to secure the mated connectors to the board with housings and cushioning materials. · Do not use the connector in non-recommended conditions (i.e., rated current, rated voltage, PCB design and operating environment, etc.). Such usage could lead to material outgassing, ignition, or short-circuit, etc. Refer to the specifications and guidelines for board pattern dimensions, board cautions, and connector treatment. Please contact Hirose if connector usage in conditions other than those described in the specifications and the guidelines is being considered.

Precautions for Handling During Use

● About Setting The Distance Between PCBs

Use within the specified dimensions between PCBs below.

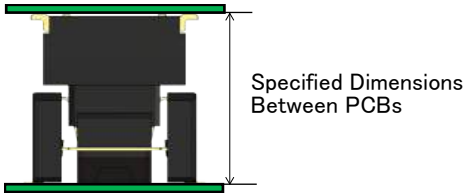

Stacking Height	Specified Dimensions Between PCBs	Plug	Receptacle
3.5mm	3.5 to 3.75mm	DF40F(2.0)-30DP-0.4V	DF40TC-30DS-0.4V
4.0mm	4.0 to 4.25mm		DF40TC(2.0)-30DS-0.4V
4.5mm	4.5 to 4.75mm		DF40TC(2.5)-30DS-0.4V
5.0mm	5.0 to 5.25mm		DF40TC(3.0)-30DS-0.4V
5.5mm	5.5 to 5.75mm		DF40TC(3.5)-30DS-0.4V
6.0mm	6.0 to 6.25mm		DF40TC(4.0)-30DS-0.4V

*Stacking Height in Under Planning

● Securing PCBs

This connector can absorb misalignment between PCBs, but not vibration.

If you support PCBs only with the connectors without taking any fixing measures, the load on the connectors will be excessive and may cause broken or contact failure.

Be sure to secure PCBs except for the connectors as shown below to prevent the board from moving. This connector connects the board to the board.

When using mounting to FPC, fasten the board and FPC to the case separately.

Fixing PCBs with a Spacer or Case

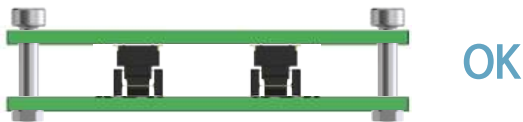

Do not use the product without fixing PCBs together.



● Mating Precautions

1. Mating

The alignment dimension is $\pm 0.3\text{mm}$ in the X and Y directions.

After the start of mating, follow the alignment and mate perpendicularly to the board without applying an overloading to the connector.

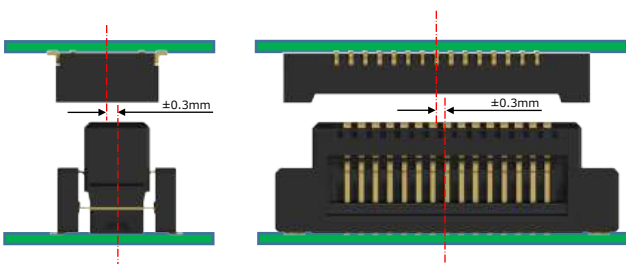

2. Misalignment Allowance in Mated Condition (Floating Range)

Because of floating design, this connector has a $\pm 0.3\text{mm}$ board misalignment tolerance in the X and Y directions when mated. However, it is not suitable for absorption when the range of misalignment constantly changes due to vibration, etc. The number of repetitions of floating movable operations is stipulated to be no more than 10 times.

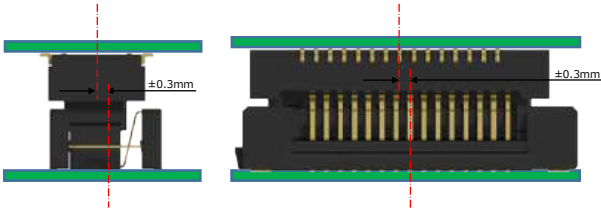

3. Removing

When removing the connector, pull it out in parallel.
If it is removed in an inclined position, connector may deform.

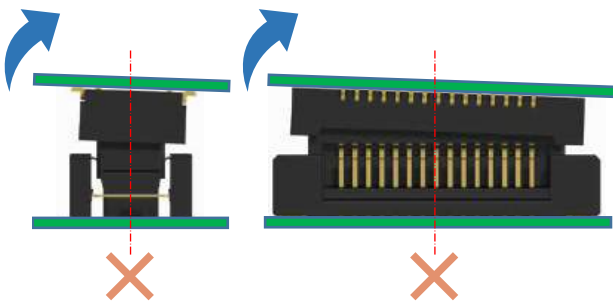

While Taking into Consideration

Specifications mentioned in this catalog are reference values.

When considering to order or use this product, please review the Drawing and Product Specifications sheets.

Use an appropriate cable when using the connector in combination with cables.

If considering usage of a non-specified cable, please contact your sales representative.

If assembly process is done by jigs & tools which are not identified by Hirose, the warranty of the product may be affected.

If considering usage for below mentioned applications, please contact your sales representative.

In cases where the application will demand a high level of reliability, such as automotive, medical instruments, public infrastructure, aerospace/defense etc. Hirose must review before assurance of reliability can be given.