

## GT50 Series

# 1mm Pitch, Single Row, Small Size, Heat/Vibration Resistant Wire-to-Board Connector for Automotive Internal Connection

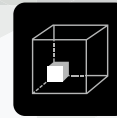

Space Saving



High Reliability



High Temp

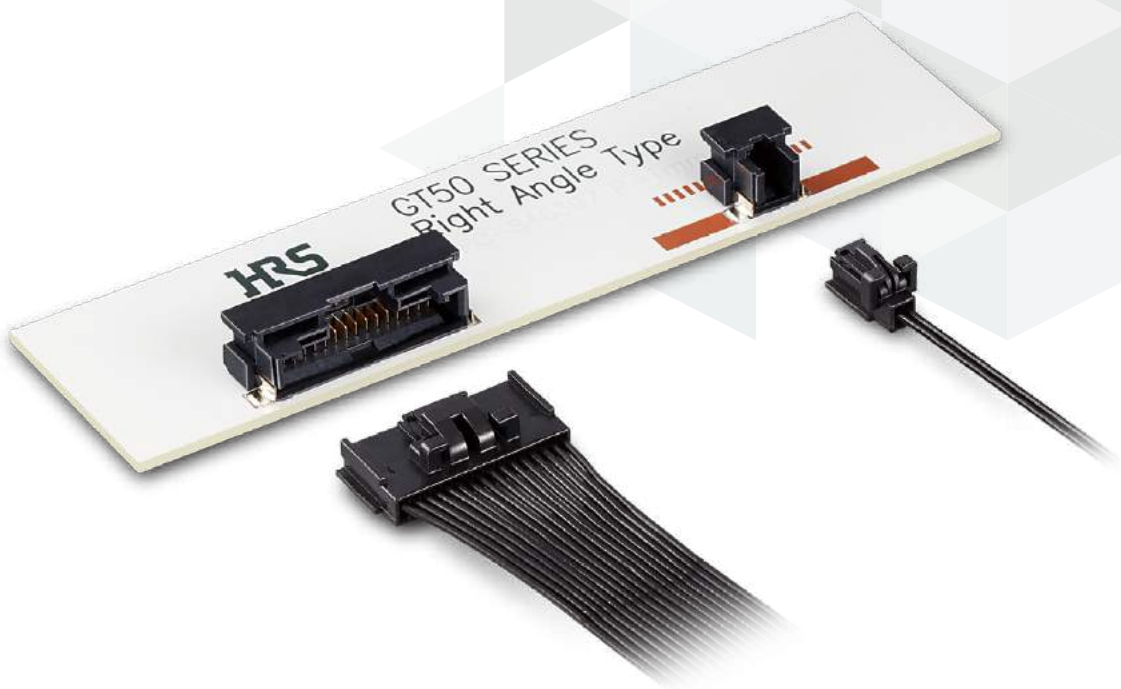

## Features

### 1. Compact and Low Profile (1mm Pitch)

Space-saving design that contributes to size reduction of end product.

### 2. High Heat Resistance up to 125°C

125°C heat resistance (Note) makes GT50 ideal for applications requiring high heat resistance such as automotive.

Note : Includes temperature rise due to current flow.

### 3. High Vibration Resistance

The stabilizer which suppresses vibration from the outside, reduces contact wear between the receptacle contact and crimp contact and achieves stable contact even under intense vibration.

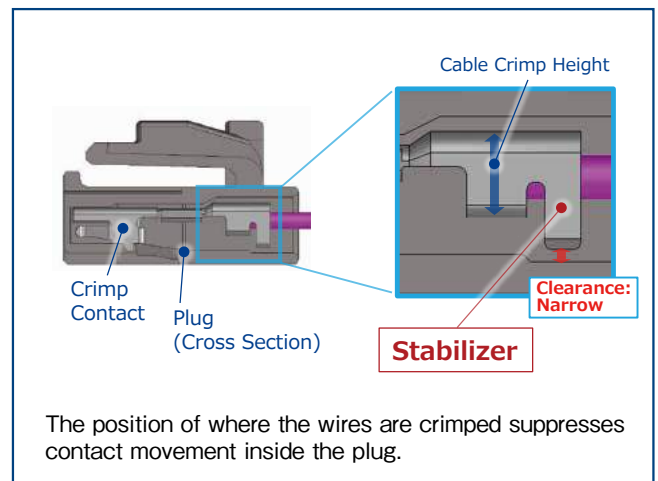

### 4. Robust design for cable routing that resists disconnecting.

GT50 has high strength in a compact size.

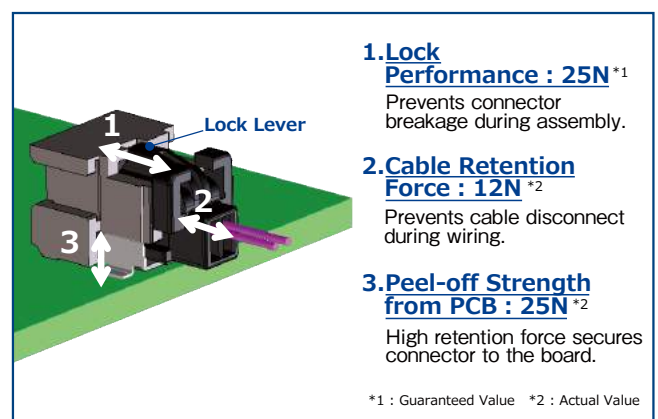

### 5. User-Friendly Lock Design

Incomplete mating prevention for enhanced contact reliability.

## Product Specifications

|               |           |                  |                                 |   |
|---------------|-----------|------------------|---------------------------------|---|
| Rated Current | 2, 4pos.  | 6, 8, 12, 16pos. | Operating Temperature (Note 1)  | -40 to +125°C                                   |
|               | 2A        | 1.5A             | Storage Temperature (Note 2)    | -10 to +60°C                                    |
| Rated Voltage | 60V AC/DC |                  | Storage Humidity Range (Note 2) | Relative Humidity 86% Max.<br>(No Condensation) |

| Items                 | Specifications   | Conditions   |
|-----------------------|--|--|
| Contact Resistance    | 30m Ω Max.   | Measured at 1mA DC, 20mV AC  |
| Insulation Resistance | 500M Ω Min.  | Measured at 100V DC  |
| Withstanding Voltage  | There shall be no dielectric breakdown.  | 300V AC for 1 min.   |
| Mating Durability     | Contact Resistance : 50m Ω Max.  | 10 Insertion/Extraction cycles   |
| Vibration Resistance  | No electrical discontinuity of 1 μ s or more.<br>Contact Resistance : 50m Ω Max. | Frequency : 5 to 600Hz<br>(Constant Acceleration of 5 to 14.9Hz : 16.5mm(p-p),<br>Constant Acceleration of 14.9 to 600Hz : 73.0m/s <sup>2</sup> )<br>8 hours in 3 directions |
| Shock Resistance      | No electrical discontinuity of 1 μ s or more.                                    | Peak Acceleration : 500m/s <sup>2</sup><br>10 cycles in each direction of 3 axes   |
| Lock Strength         | 25N Min.   | Lock breaking strength measured when pulling in mating axis direction  |
| Humidity Resistance   | Contact Resistance : 50m Ω Max.<br>Insulation Resistance : 100M Ω Min.           | Left for 96 hours at a temperature of 60°C and a relative humidity humidity 90 to 95%  |
| Thermal Shock         | Contact Resistance : 50m Ω Max.  | Temperature : -40°C → Room temperature → +125°C<br>→ Room temperature<br>Time : 30 → 5 → 30 → 5 minutes for 1000 cycles  |
| Heat Resistance       | Contact Resistance : 50m Ω Max.  | Left at 125°C for 1000 hours   |
| Cold Resistance       | Contact Resistance : 50m Ω Max.  | Left at -40°C for 1000 hours   |

Note 1 : Includes temperature rise caused by current flow.

Note 2 : Storage refers to long-term storage of unused items before they are mounted on the PCB.

Operating temperature and humidity range apply when the product is not powered after PCB mounting and when temporarily stored during transportation.

## Materials / Finish

| Component     | Part           | Material     | Color / Finish                           | UL Standard |
|---------------|----------------|--------------|--|-------------|
| Receptacle    | Housing        | LCP          | Black                                    | UL94V-0     |
|               | Contact        | Brass        | Gold Plating (Contact Area and SMT Lead) | —           |
|               | Retention Tabs | Brass        | Tin Plating                              | —           |
| Plug          | Housing        | PBT          | Black                                    | UL94V-0     |
| Crimp Contact |                | Copper Alloy | Gold Plating (Contact Area)              | —           |

## Product Number Structure

Refer to the chart below when determining the product specifications from the product number.  
Please select from the product numbers listed in this catalog when placing orders.

### Receptacle / Plug

**GT50 - 2 P - 1 H**

①      ② ③      ④ ⑤

### Crimp Contact

**GT50 - 28 SCFA**

①      ⑥      ⑦

|                  |                            |                        |   |
|------------------|----------------------------|------------------------|---|
| ① Series Name    | GT50                       | ④ Pitch                | 1mm   |
| ② No. of Pos.    | 2, 4, 6, 8, 12, 16         | ⑤ Product Type         | H : SMT Right Angle Type<br>C : Crimp Housing |
| ③ Connector Type | P : Receptacle<br>S : Plug | ⑥ Applicable Cable     | 28 AWG (0.08sq)                               |
|                  |                            | ⑦ Type /Packaging Type | Contact / Reel                                |

## Right Angle Receptacle

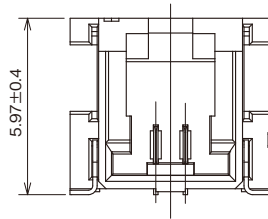
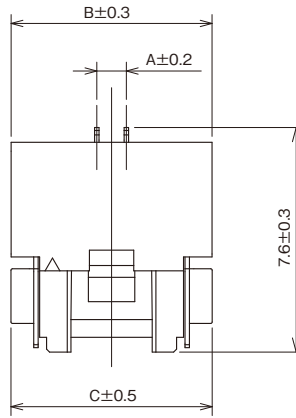

### ● Recommended PCB Layout

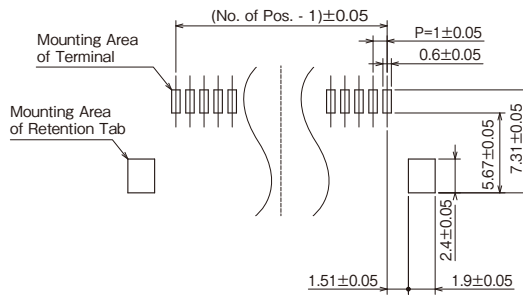

Unit : mm

| Part No.    | HRS No.          | No. of Pos. | A    | B    | C     | Purchase Unit     |
|-------------|------------------|-------------|------|------|-------|-------------------|
| GT50-2P-1H  | CL0760-1002-0-00 | 2           | 1.0  | 6.8  | 6.81  | 1,000pcs per reel |
| GT50-4P-1H  | CL0760-1004-0-00 | 4           | 3.0  | 8.8  | 8.81  |                   |
| GT50-6P-1H  | CL0760-1006-0-00 | 6           | 5.0  | 10.8 | 10.81 |                   |
| GT50-8P-1H  | CL0760-1008-0-00 | 8           | 7.0  | 12.8 | 12.81 |                   |
| GT50-12P-1H | CL0760-1010-0-00 | 12          | 11.0 | 16.8 | 16.81 |                   |
| GT50-16P-1H | CL0760-1012-0-00 | 16          | 15.0 | 20.8 | 20.81 |                   |

## Plug



Shown with crimp contact inserted.

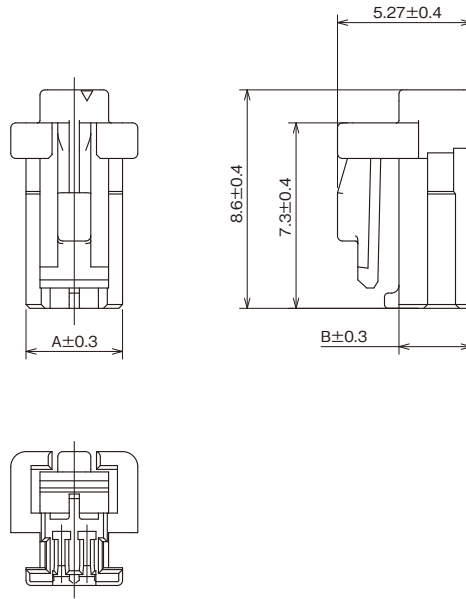

Unit : mm

| Part No.    | HRS No.          | No. of Pos. | A    | B    | Purchase Unit     |
|-------------|------------------|-------------|------|------|-------------------|
| GT50-2S-1C  | CL0760-1003-0-00 | 2           | 3.8  | 2.85 | 100pcs<br>per bag |
| GT50-4S-1C  | CL0760-1005-0-00 | 4           | 5.8  |      |                   |
| GT50-6S-1C  | CL0760-1007-0-00 | 6           | 7.8  |      |                   |
| GT50-8S-1C  | CL0760-1009-0-00 | 8           | 9.8  | 3.44 |                   |
| GT50-12S-1C | CL0760-1011-0-00 | 12          | 13.8 |      |                   |
| GT50-16S-1C | CL0760-1013-0-00 | 16          | 17.8 |      |                   |

## Crimp Contact

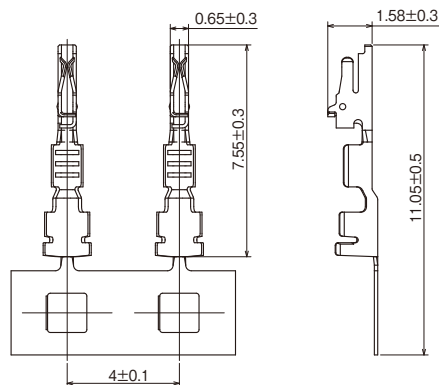

| Part No.    | HRS No.          | Applicable Cable  | Purchase Unit         |
|-------------|------------------|---|-----------------------|
| GT50-28SCFA | CL0760-1001-0-00 | 28 AWG (0.08sq)<br>Coated Outer Diameter $\phi$ 0.7-0.8mm | 28,000pcs<br>per reel |

## Mated Diagram

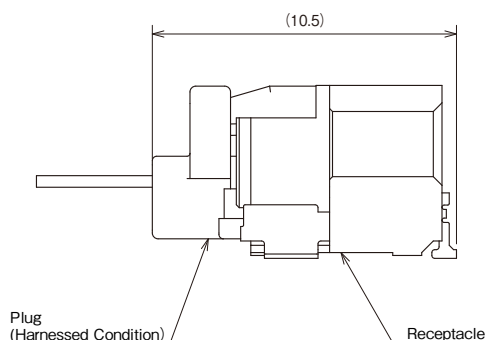

## Applicable Tools

| Type  | Part No.        | HRS No.          | Compatible Crimp Contact |
|---|-----------------|------------------|--------------------------|
| Hirose Crimping Tool                        | CM-105C         | CL0901-0001-0-00 | -                        |
| Applicator for Hirose Crimping Tool         | AP105-GT50-28S  | CL0901-5257-0-00 | GT50-28SCFA              |
| Japan Automatic Machine Applicator (Note 1) | EHX106000H-UP   | -                | GT50-28SCFA              |
| Hand Tool (Note 2)                          | HT307/GT50-28SA | CL0902-5166-0-00 | GT50-28SCFA              |

Note 1 : Contact Japan Automatic Machine (J.A.M.) regarding crimping failure relating to applicable J.A.M. applicators or for other applicator inquiries via the J.A.M. website. (URL : <http://www.jam-net.co.jp>)

Note 2 : Hand tools are developed as a prototype tool during product development. Use an applicator for mass production.

Note 3 : Crimping should be carried out based on the "Crimping Quality Standards" and "Crimping Conditions Table."

Note 4 : Problems caused by tools other than those specified are not covered by the warranty.

## Usage Precautions

|   |  |   |
|---|--|---|
| Recommended Temperature Profile         | <p>Temperature(°C)</p> <p>Time(s)</p> <p>250°C</p> <p>230°C</p> <p>180°C</p> <p>150°C</p> <p>100°C</p> <p>90~120s</p> <p>30±10s</p>  | <p><b>【Conditions】</b></p> <ol style="list-style-type: none"> <li>1. Reflow Heating Method Used :<br/>Far infrared, air atmosphere or nitrogen</li> <li>2. Peak Temperature 250°C Peak</li> <li>3. Heated part 230°C Min. 20-40 sec.</li> <li>4. Preheat Temperature 150 to 180°C 90-120 sec.</li> <li>5. Cycles 2 times Max.</li> <li>6. Recommended Solder Thickness : 0.1mm</li> </ol> |
| Recommended Manual Soldering Conditions | Soldering iron temperature : 350 to 380°C , Soldering time : within 5 seconds  |   |
| Precautions                             | <ol style="list-style-type: none"> <li>1. Excessive pull force during unmating may damage the connector. If it is difficult to remove, push in lightly once and then release the lock.</li> <li>2. Always make sure to turn off the power before reinserting the connector.</li> <li>3. Do not directly touch the terminal when electricity is flowing since it is extremely dangerous.</li> <li>4. Contact a Hirose representative for harness procedures or handling manuals.</li> </ol> |   |

## While Taking into Consideration

Specifications mentioned in this catalog are reference values.

When considering to order or use this product, please review the Drawing and Product Specifications sheets.

Use an appropriate cable when using the connector in combination with cables.

If considering usage of a non-specified cable, please contact your sales representative.

If assembly process is done by jigs & tools which are not identified by Hirose, the warranty of the product may be affected.

If considering usage for below mentioned applications, please contact your sales representative.

In cases where the application will demand a high level of reliability, such as automotive, medical instruments, public infrastructure, aerospace/defense etc. Hirose must review before assurance of reliability can be given.