

Oct.1.2024 Copyright 2024 HIROSE ELECTRIC CO., LTD. All Rights Reserved.
In case of consideration for using Automotive equipment / device which demand high reliability, kindly contact our sales window correspondents.

Notes. 1. Recommended cable condition is shown below.
 ⚠ A list of compatible cables is available on the Hirose website.
 When using a non-recommended cable, please contact a Hirose sales representative.
 Refer to the technical specification (ETAD-E3213) for wiring and assembly procedures.

⚠ Recommended Cable

Items		⚠ Recommended Condition
Conductor	Size	AWG#22
	Composition	7 stranded
	Material	Annealed copper wire
Insulation O.D.		φ1.4 to 1.6mm
Braid Shield		Tin plating
Sheath O.D.		φ6.3 to 7.2mm

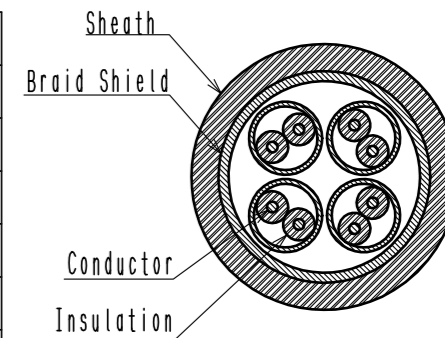

2. This product (Type B) is used for non Ethernet applications like signaling, serial or other industrial bus communication systems. Please use Type A for 10/100 Mbit/s and 1/10 Gbit/s Ethernet communication.

⚠ Mating Key

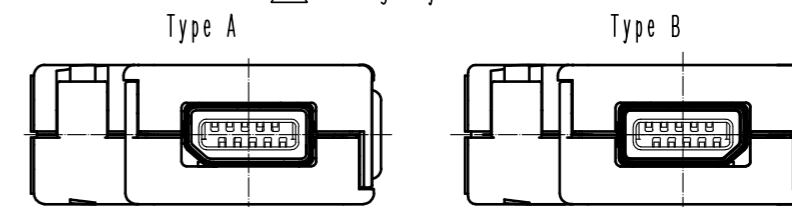

⚠ ③ Excluding the plug unit, this product is packaged separately by the type of parts. The shield shell is packaged prior to bending. (See next page.) Refer to the technical specification (ETAP-E3224) for packing.

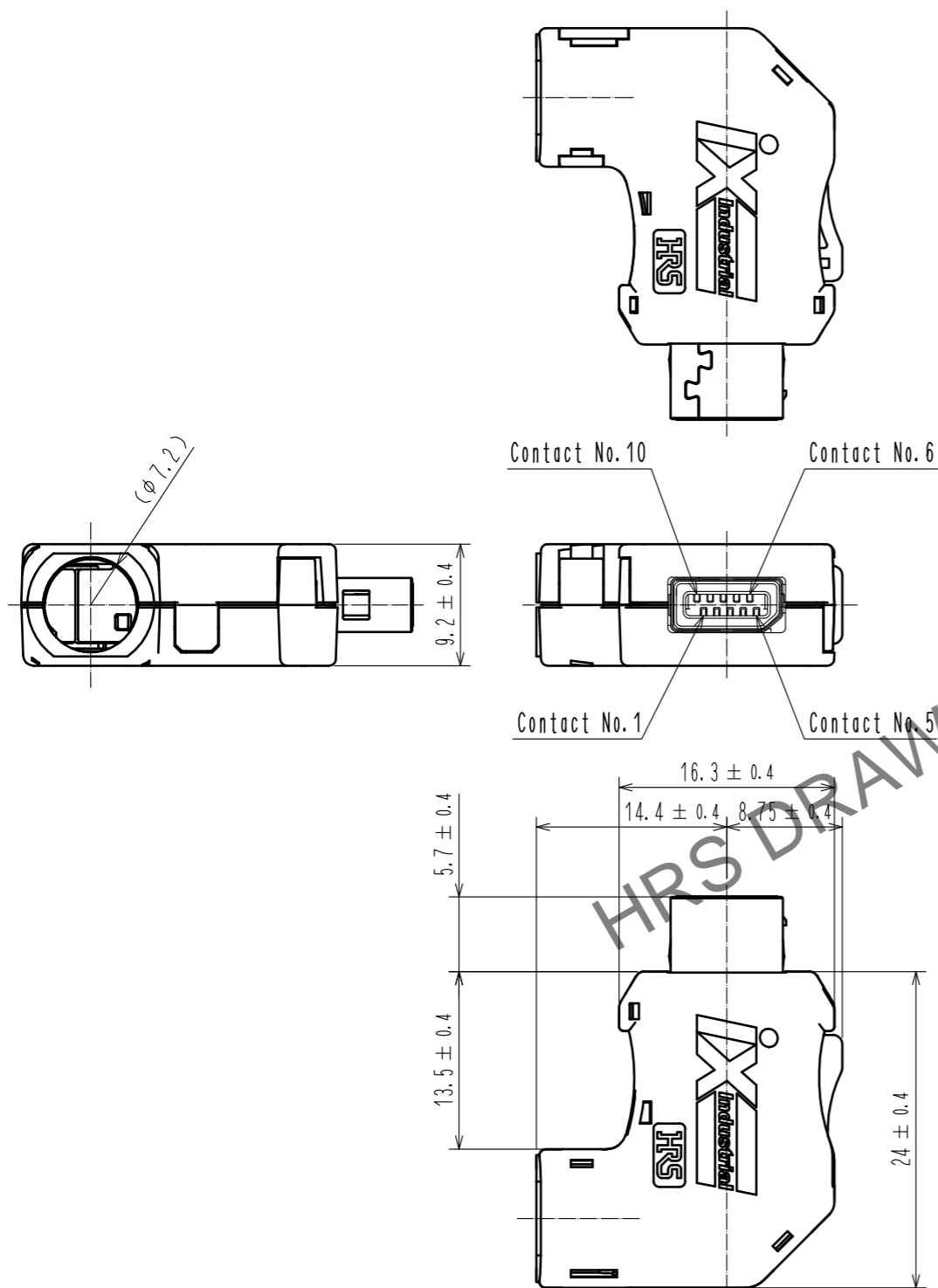

NO.	MATERIAL	FINISH . REMARKS	NO.	MATERIAL	FINISH . REMARKS
4	PA	Black, UL94V-0	9	PC	Dark gray, UL94V-0
3	Stainless Steel		8	PC	Dark gray, UL94V-0
2	PA	Dark gray, UL94V-0	7	Stainless Steel	Nickel 0.2 μm min
1	Copper Alloy	Contact area : Palladium-Nickel 0.75 μm min + Gold 0.05 μm min Wiring area : Gold 0.03 μm min Under plating : Nickel 2 μm min	6	Stainless Steel	Nickel 1 μm min
			5	PC	Clear blue, UL94V-0

UNITS	SCALE	COUNT	DESCRIPTION OF REVISIONS	DESIGNED	CHECKED	DATE
mm	2 : 1	6	DIS-E-00006883	MT. YASUDA	KI. KAGOTANI	20211025

APPROVED : MN. KENJO	20200519	DRAWING NO.	EDC-129984-01-00
CHECKED : KI. NAGANUMA	20200519	PART NO.	IX32G-B-8S-CVL1(7.0)(C01)
DESIGNED : MT. YASUDA	20200519	CODE NO.	CL0251-0072-0-01
DRAWN : MY. KOMUKAI	20200519		

Oct.1.2024 Copyright 2024 HIROSE ELECTRIC CO., LTD. All Rights Reserved.
 In case of consideration for using Automotive equipment / device which demand high reliability, kindly contact our sales window correspondents.

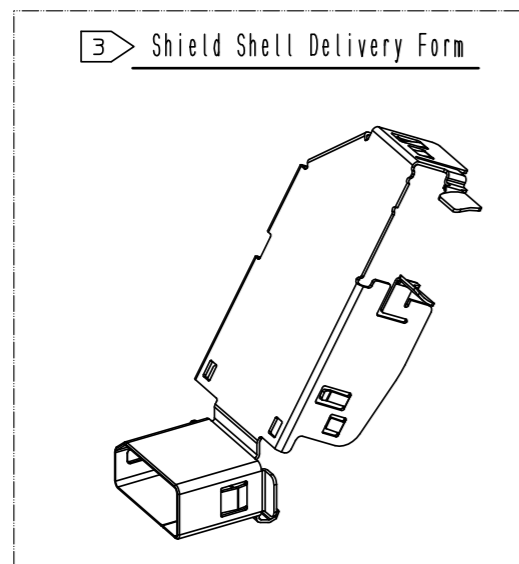

Product Structure

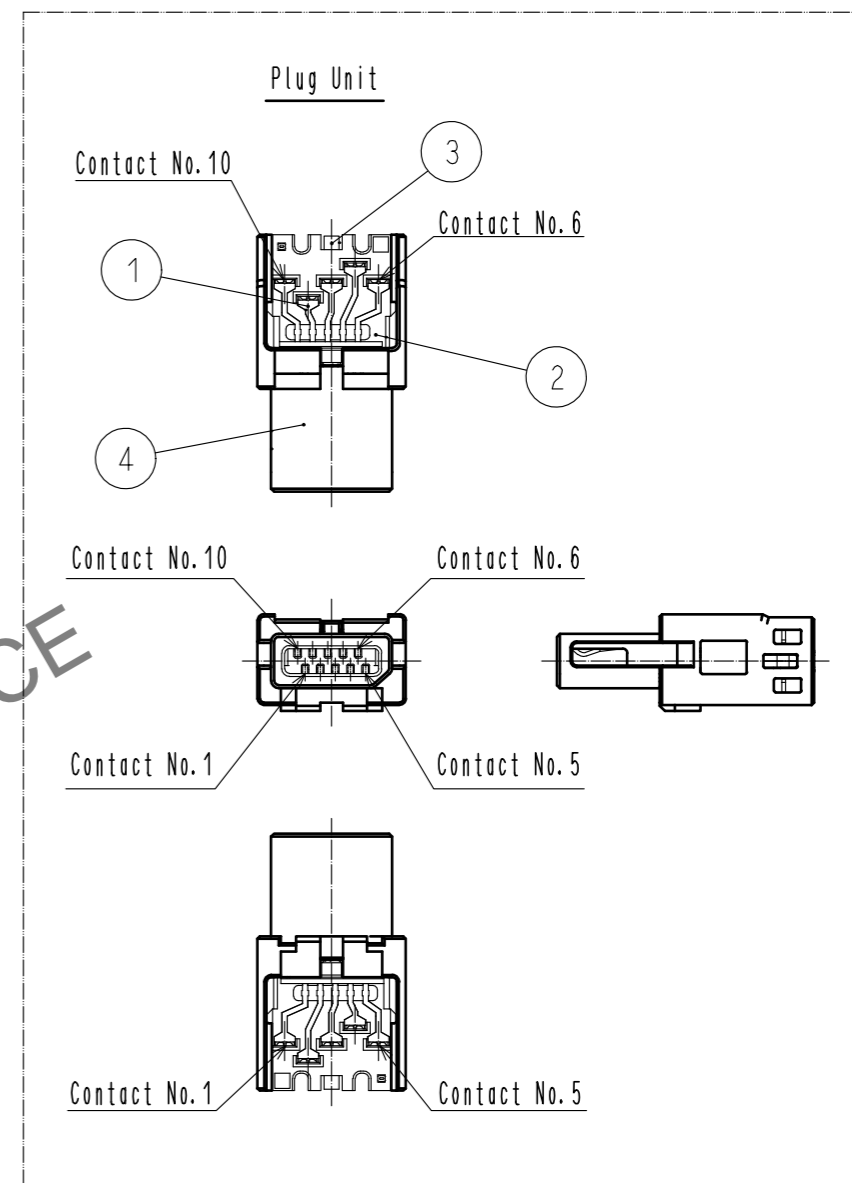
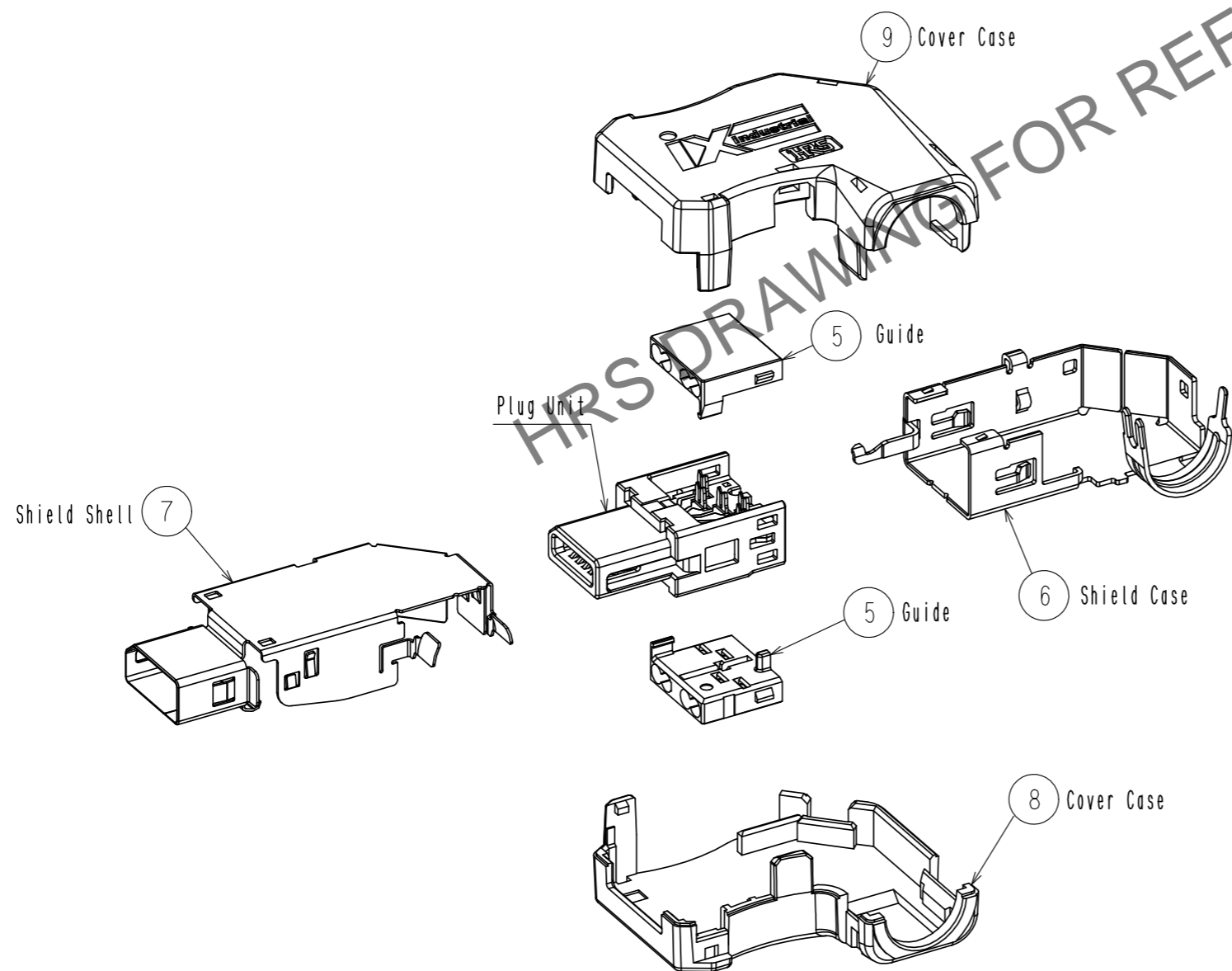

Mated Condition

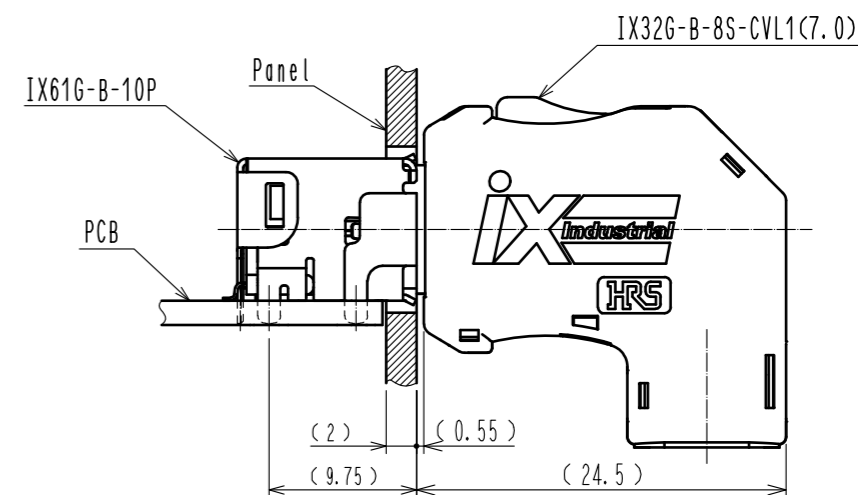

HRS	DRAWING NO.	EDC-129984-01-00
	PART NO.	IX32G-B-8S-CVL1(7.0)(01)
	CODE NO.	CL0251-0072-0-01
		△ 2/2