

Sep.1.2024 Copyright 2024 HIROSE ELECTRIC CO., LTD. All Rights Reserved.
 In case of consideration for using Automotive equipment / device which demand high reliability, kindly contact our sales window correspondents.

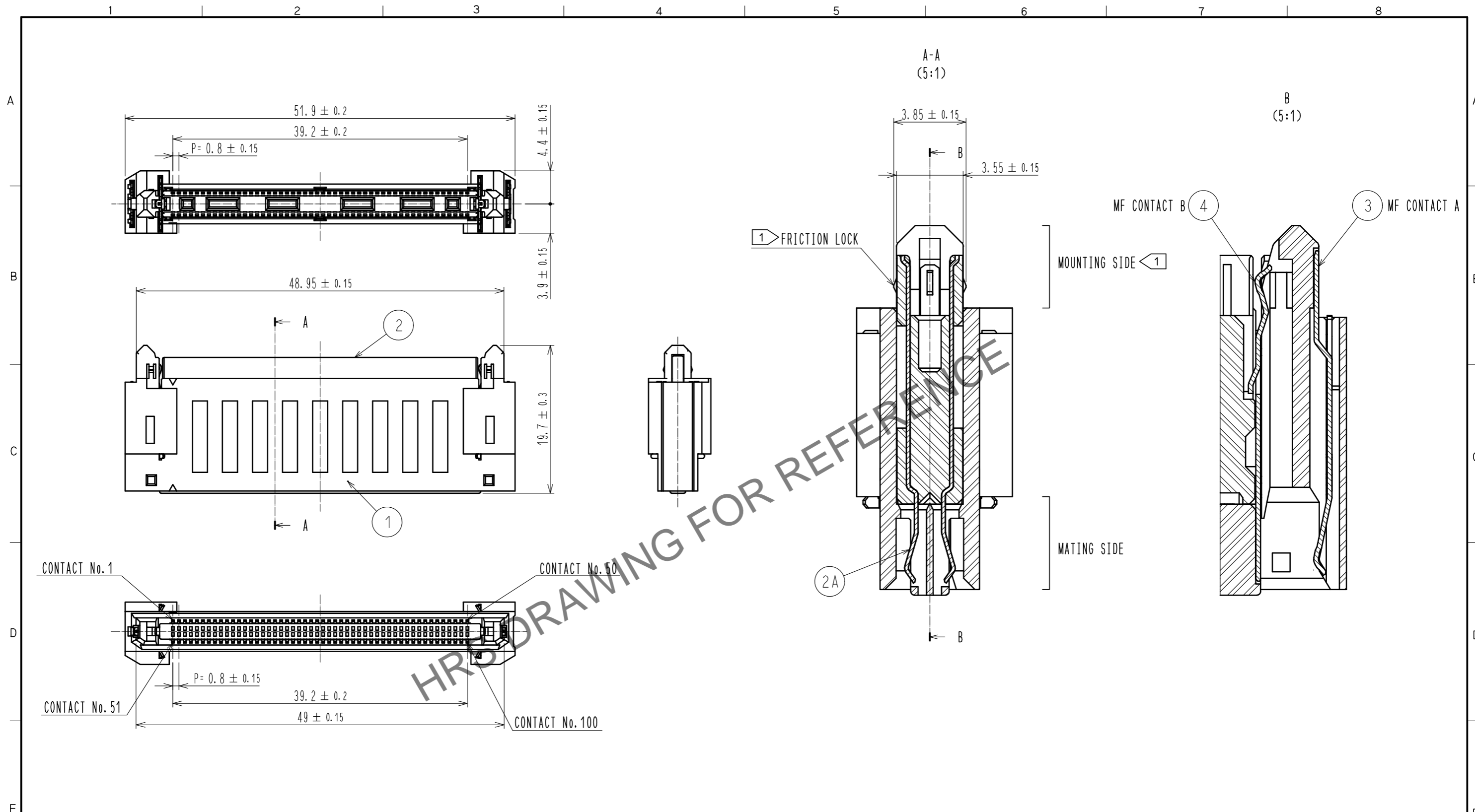

- NOTE
- 1 MOUNTING SIDE IS CONNECTED TO THE RECEPTACLE:FX18-100S-0.8SV** AND STABILIZED WITH FRICTION LOCKS. THE INSERTION/WITHDRAWAL IS ALLOWED UP TO 5 TIMES.
 - 2 ALWAYS CONNECT THE MOUNTING SIDE TO THE RECEPTACLE FIRST AND THEN MATE THE MATING SIDE TO FX18-100P-0.8SV**.
 - 3 THE MATING SIDE HAS SEQUENTIAL CONTACT STRUCTURE AS FOLLOWS.(MF CONTACT A=>SIGNAL CONTACT=>MF CONTACT B) WHEN USING THIS SEQUENTIAL STRUCTURE, PLEASE AVOID ANGLED INSERTION.
 - 4 MF CONTACT A AND MF CONTACT B CAN BE USED AS POWER SUPPLY CONTACT. (3A/PIN MAX)
 - 5 THIS IS PACKAGED IN TRAY.(40pcs/TRAY)
 - 6 BLEMISH AND HIT MARK CAN BE OCCURED THROUGH OUT THE MANUFACTURING PROCESS WHICH DOESN' T AFFECT QUALITY LEVEL.
 - 7 THE DIMENSIONS IN PARENTHESES ARE FOR REFERENCES.
 - 8 RECOMMENDED SPACER HEIGHT FOR EACH COMBINATION. SPACERS ARE REQUIRED TO PROTECT THE SOLDER JOINTS FROM EXCESSIVE STRESS.

NO.	MATERIAL	FINISH	REMARKS	NO.	MATERIAL	FINISH	REMARKS
2A	COPPER ALLOY		CONTACT AREA:GOLD 0.1 μm UNDER PLATING:NICKEL 1.3 μm	4	COPPER ALLOY		CONTACT AREA:GOLD 0.1 μm UNDER PLATING:NICKEL 1.3 μm
2	PBT		BLACK UL94V-0	3	COPPER ALLOY		CONTACT AREA:GOLD 0.1 μm UNDER PLATING:NICKEL 1.3 μm
1	POLYAMIDE		BLACK UL94V-0				
5					POLYSTYRENE		

UNITS	SCALE	COUNT	DESCRIPTION OF REVISIONS	DESIGNED	CHECKED	DATE
mm	2 : 1	△				
APPROVED : HS. OKAWA			15.01.30	DRAWING NO. EDC-349364-00-00		
CHECKED : HT. YAMAGUCHI			15.01.30	PART NO. FX18-100PS-0.8H15		
DESIGNED : TH. SANO			15.01.29	CODE NO. CL579-0052-3-00		
DRAWN : TH. SANO			15.01.29	1/2		

Sep.1.2024 Copyright 2024 HIROSE ELECTRIC CO., LTD. All Rights Reserved.
In case of consideration for using Automotive equipment / device which demand high reliability, kindly contact our sales window correspondents.

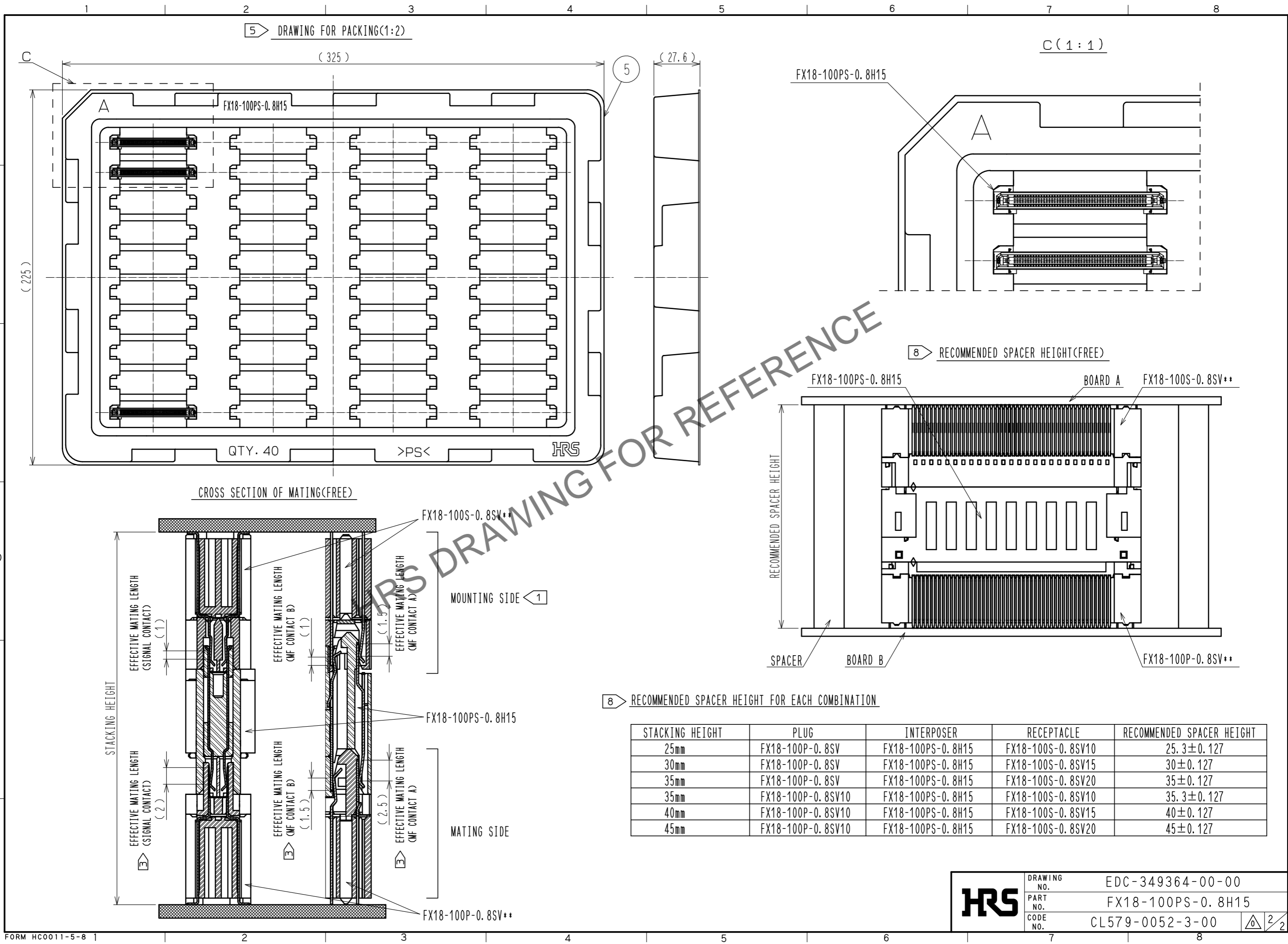

STACKING HEIGHT	PLUG	INTERPOSER	RECEPTACLE	RECOMMENDED SPACER HEIGHT
25mm	FX18-100P-0.8SV	FX18-100PS-0.8H15	FX18-100S-0.8SV10	25.3±0.127
30mm	FX18-100P-0.8SV	FX18-100PS-0.8H15	FX18-100S-0.8SV15	30±0.127
35mm	FX18-100P-0.8SV	FX18-100PS-0.8H15	FX18-100S-0.8SV20	35±0.127
35mm	FX18-100P-0.8SV10	FX18-100PS-0.8H15	FX18-100S-0.8SV10	35.3±0.127
40mm	FX18-100P-0.8SV10	FX18-100PS-0.8H15	FX18-100S-0.8SV15	40±0.127
45mm	FX18-100P-0.8SV10	FX18-100PS-0.8H15	FX18-100S-0.8SV20	45±0.127

HRS	DRAWING NO.	EDC-349364-00-00
	PART NO.	FX18-100PS-0.8H15
	CODE NO.	CL579-0052-3-00
		2/2