

Jul.1.2024 Copyright 2024 HIROSE ELECTRIC CO., LTD. All Rights Reserved.  
 In case of consideration for using Automotive equipment / device which demand high reliability, kindly contact our sales window correspondents.

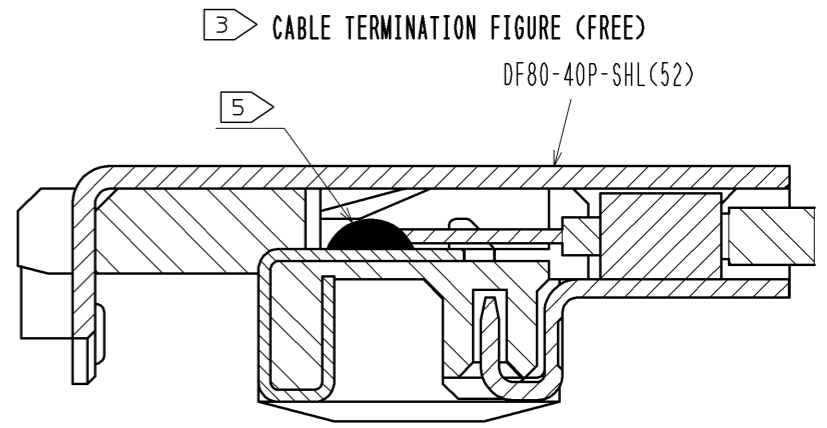
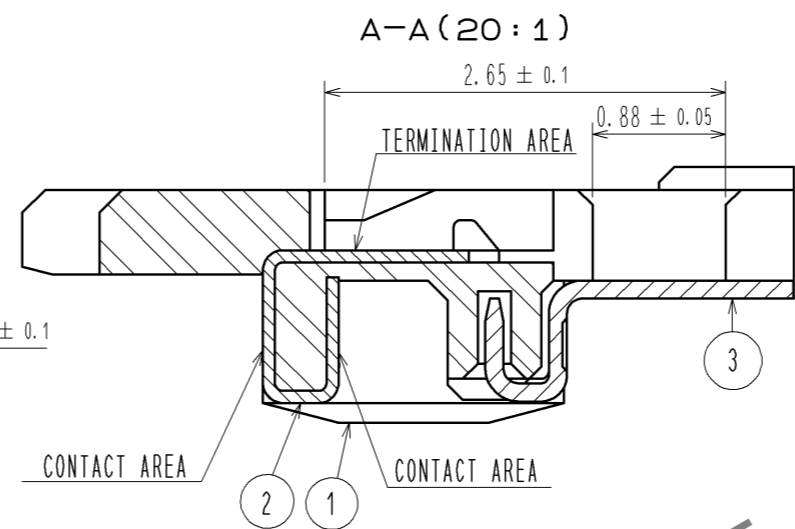
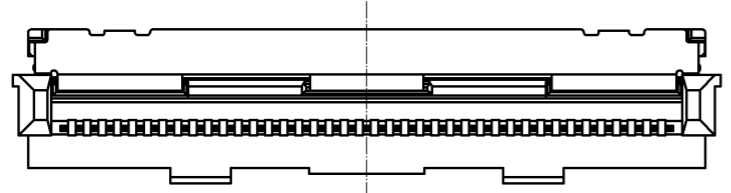
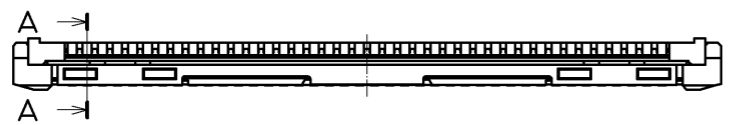
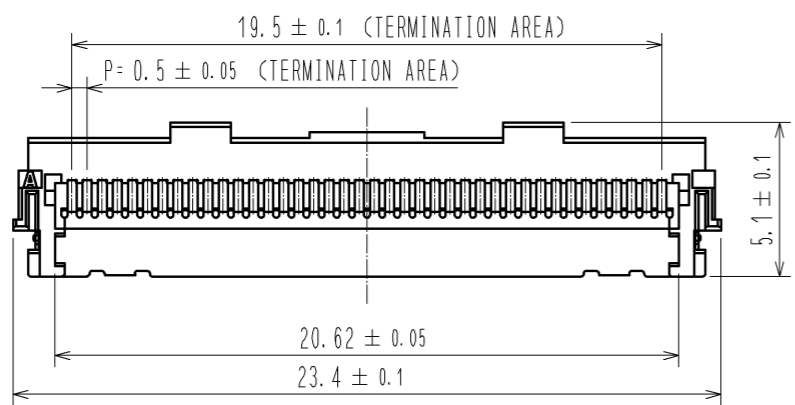
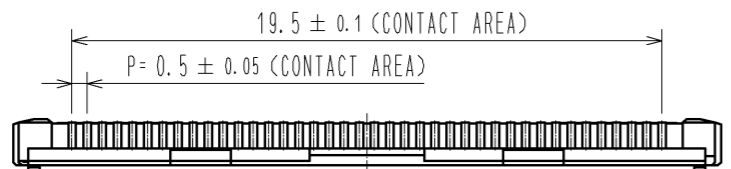

HRS DRAWING FOR REFERENCE

ITEM No.	PART NAME	PART No.	CODE No.
1, 2, 3	CONNECTOR UNIT	DF80D-40P-0.5SD(52)	CL662-8118-0-52
-	METAL SHIELDING	DF80-40P-SHL(52)	CL662-8003-8-52

- NOTES
1. APPLICABLE CABLE: DISCRETE CABLE(AWG#32~AWG#36) . MICRO COAXIAL CABLE (AWG#40~AWG#46)
  2. THIS CONNECTOR IS NOT HOT PLUGGABLE. MATE AND UNMATE WHILE THE POWER IS OFF.
  - 3 THE ASSEMBLY IS COMPLETED BY COMBINING TWO PARTS 'CONNECTOR UNIT, AND METAL SHIELDING'. REFER TO THE TABLE FOR EACH ITEM No. PART NAME, PART No AND CODE No.
  - 4 SOLDER A GRAND BAR WITH AN EXTERNAL CONDUCTOR OF THE CABLE ABOUT STICKING A GRAND BAR TOGETHER.
  - 5 PLEASE CONSULT ABOUT THE USE OF THE POTTING AND KAPTON TAPE SEPARATELY.

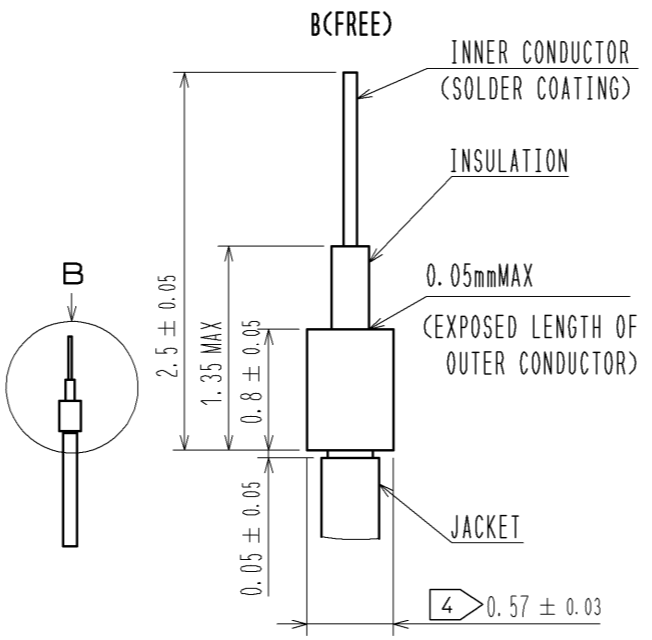
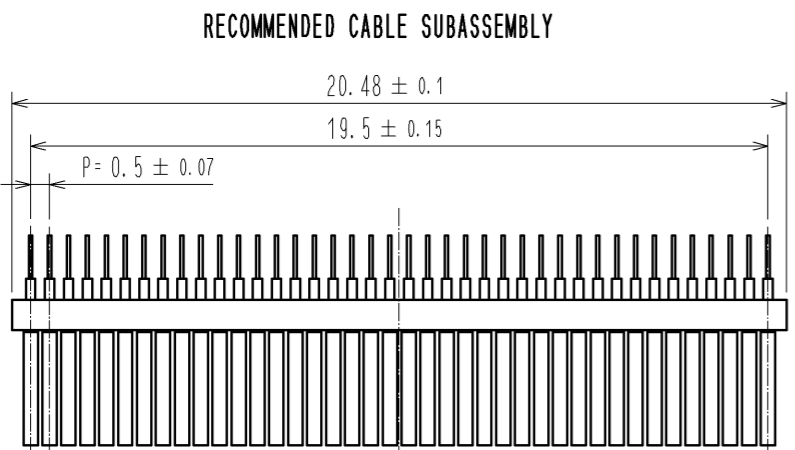

NO.	MATERIAL	FINISH	REMARKS	NO.	MATERIAL	FINISH	REMARKS
2	PHOSPHOR BRONZE	CONTACT AREA : Au PLATING 0.05μmMIN TERMINATION AREA : Au PLATING 0.05μmMIN UNDER PLATING : Ni PLATING 1μmMIN		6	PS		BLACK
1	LCP	UL94V-0 , BLACK		5	PHPOLYESTER		CLEAR
				4	PS		CLEAR
				3	STAINLESS		WHOLE AREA : Sn PLATING 1μmMIN UNDER PLATING : Ni PLATING 0.2μmMIN

UNITS	SCALE	COUNT	DESCRIPTION OF REVISIONS	DESIGNED	CHECKED	DATE
mm	FREE	△				
APPROVED : MH. YAMANE			13.08.30	DRAWING NO. EDC3-351197-02		
CHECKED : MH. TSUCHIDA			13.08.30	PART NO. DF80D-40P-0.5SD(52)		
DESIGNED : IO. DENPOUYA			13.08.29	CODE NO. CL662-8118-0-52		
DRAWN : IO. DENPOUYA			13.08.29	△ 1/2		

Jul.1.2024 Copyright 2024 HIROSE ELECTRIC CO., LTD. All Rights Reserved.  
 In case of consideration for using Automotive equipment / device which demand high reliability, kindly contact our sales window correspondents.

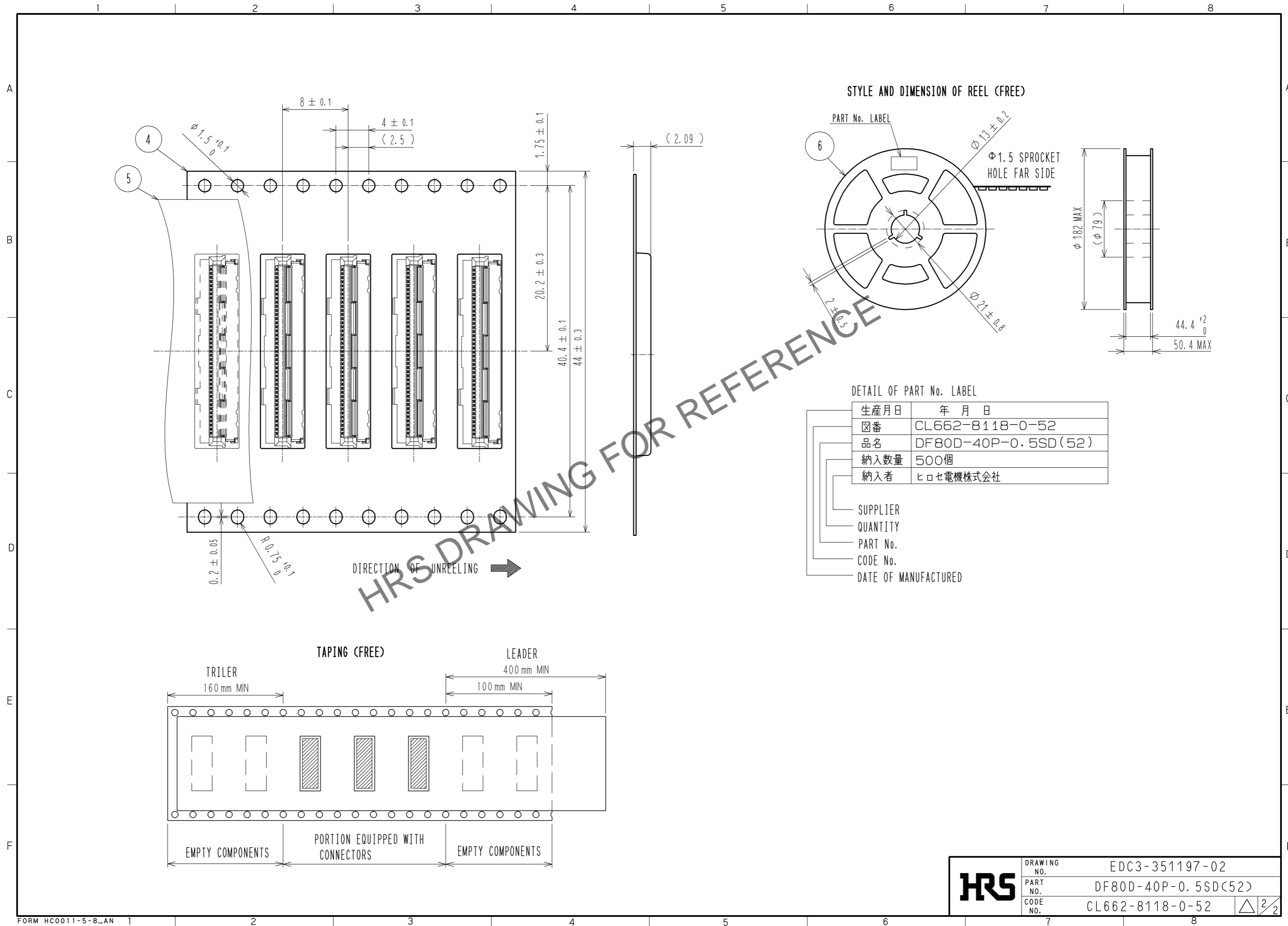

<b>HRS</b>	DRAWING NO.	EDC3-351197-02
	PART NO.	DF80D-40P-0.5SD(52)
	CODE NO.	CL662-8118-0-52
		$\triangle$ 2/2