

Oct.1.2024 Copyright 2024 HIROSE ELECTRIC CO., LTD. All Rights Reserved.
In case of consideration for using Automotive equipment / device which demand high reliability, kindly contact our sales window correspondents.

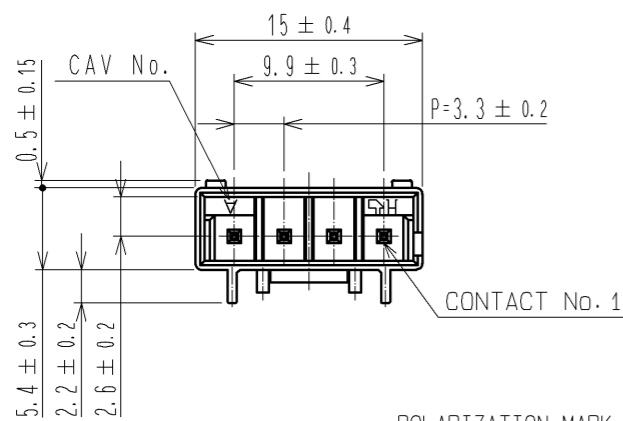

RECOMMENDED PATTERN(5:1)
(RECOMMENDED BOARD THICKNESS t=1.6mm)

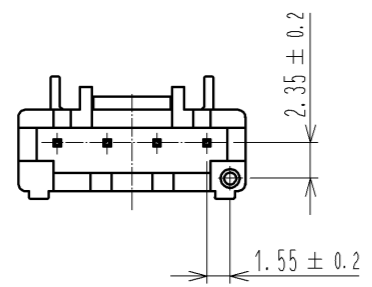
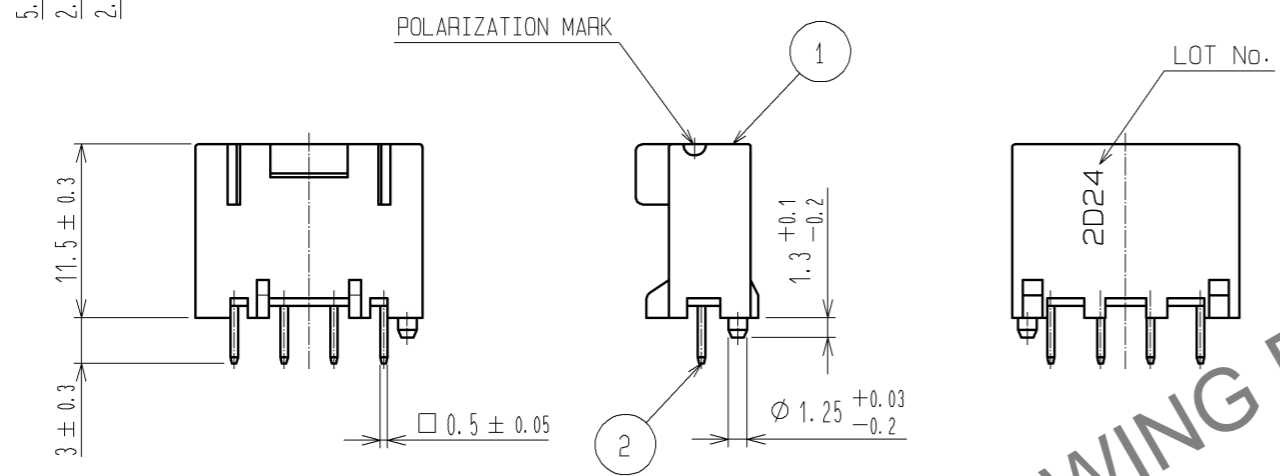
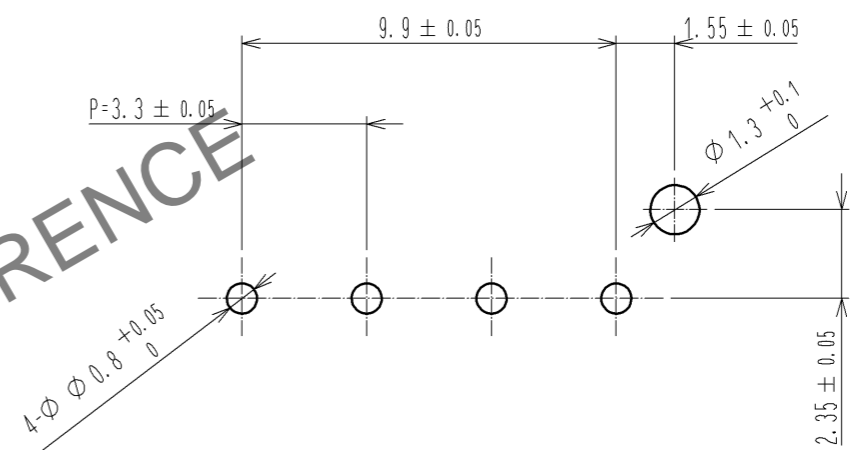

HRS DRAWING FOR REFERENCE

APPLICATION DIAGRAM

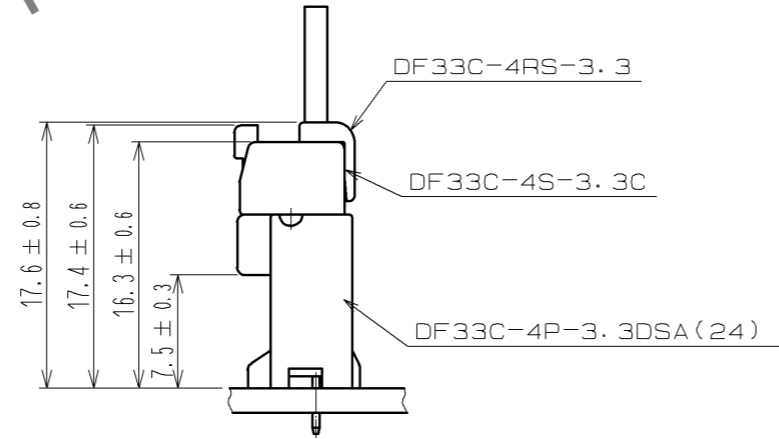

NOTES 1 :IMMERSION DEPTH INTO POTTING SOLUTION:6.5mm

1	PBT	WHITE, UL94V-0	3	HIPS	TRAY
2	BRASS		2	BRASS	SURFACE:TIN PLATED 1µm min UNDER PLATING:NICKEL PLATED 0.5µm min
NO.	MATERIAL	FINISH . REMARKS	NO.	MATERIAL	FINISH . REMARKS
UNITS	⊙	SCALE	△	DESCRIPTION OF REVISIONS	
mm		2 : 1		DESIGNED	CHECKED
APPROVED : KI. AKIYAMA		13.08.23	DRAWING NO. EDC3-338422-01		
CHECKED : HK. UMEHARA		13.08.23	PART NO. DF33C-4P-3.3DSA(24)		
DESIGNED : HT. SATO		13.08.23	CODE NO. CL676-1133-8-24		
DRAWN : MI. SAKIMURA		13.08.23	1/2		

Oct.1.2024 Copyright 2024 HIROSE ELECTRIC CO., LTD. All Rights Reserved.
In case of consideration for using Automotive equipment / device which demand high reliability, kindly contact our sales window correspondents.

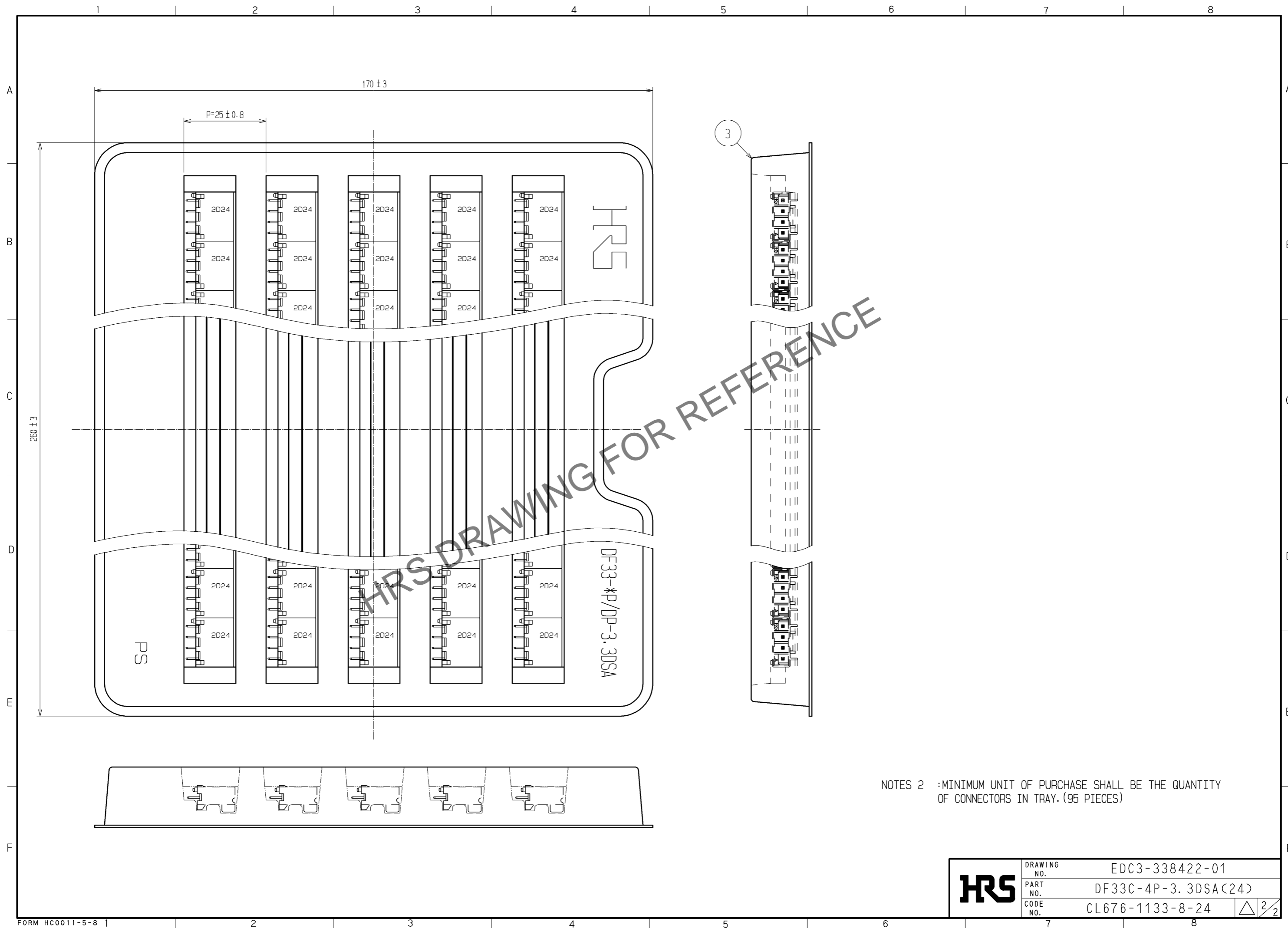

NOTES 2 :MINIMUM UNIT OF PURCHASE SHALL BE THE QUANTITY OF CONNECTORS IN TRAY. (95 PIECES)

HRS	DRAWING NO.	EDC3-338422-01
	PART NO.	DF33C-4P-3, 3DSA(24)
	CODE NO.	CL676-1133-8-24

△ 2/2