

Apr.1.2026 Copyright 2026 HIROSE ELECTRIC CO., LTD. All Rights Reserved.  
 In case of consideration for using Automotive equipment / device which demand high reliability, kindly contact our sales window correspondents.

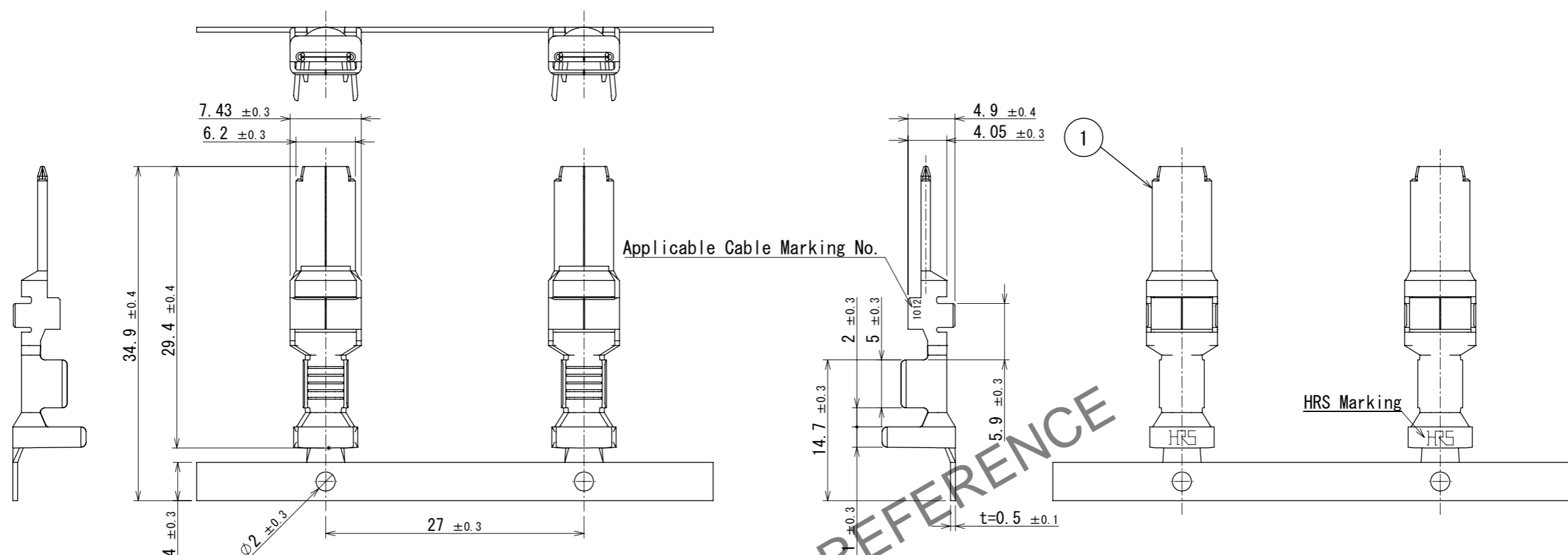

Applicable Cable Marking No.

HRS Marking

Figure with crimp contact in crimp socket

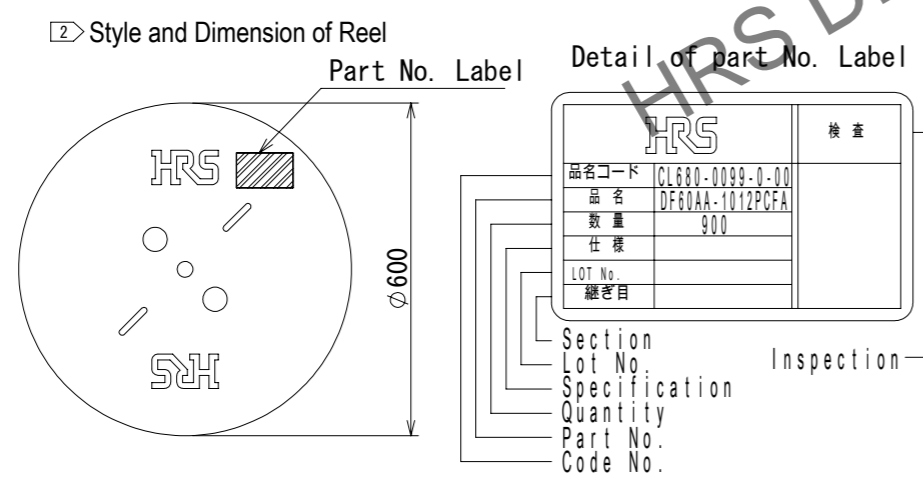
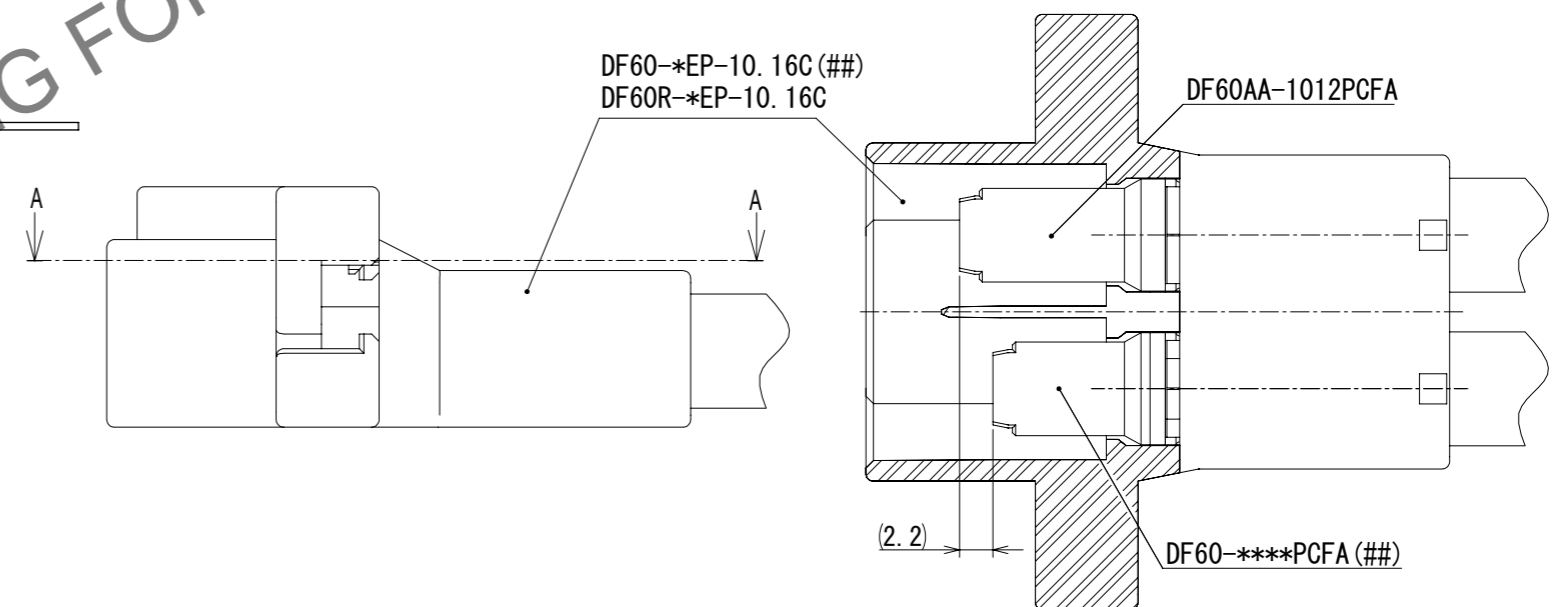

- Note 1. 1Reel: 900 Contacts.  
 2. Style of Reel and Box Shows in Figure.  
 3. Please be sure to check the form of crimping with a cable while adjusting applicator.  
 4. This product is the sequential connection contact for DF60-1012PCFA(##).

NO.	MATERIAL	FINISH	REMARKS
1	Copper alloy	• Contact Area Surface : Au Plating 0.2μm min • Under Plating : Ni Plating 1μm min • Others : Ni Plating 0.2μm min	

UNITS	SCALE	COUNT	DESCRIPTION OF REVISIONS	DESIGNED	CHECKED	DATE
mm	2:1	△				2025.04.07
APPROVED : SJ. OKAMURA			2025.04.25	DRAWING NO. EDC-408381-00-00		
CHECKED : SZ. ONO			2025.04.25	PART NO. DF60AA-1012PCFA		
DESIGNED : SS. YAMASAKI			2025.04.25	CODE NO. CL0680-0099-0-00		
DRAWN : SK. CHIBA			2025.04.25			

