

Mar.1.2026 Copyright 2026 HIROSE ELECTRIC CO., LTD. All Rights Reserved.  
In case of consideration for using Automotive equipment / device which demand high reliability, kindly contact our sales window correspondents.

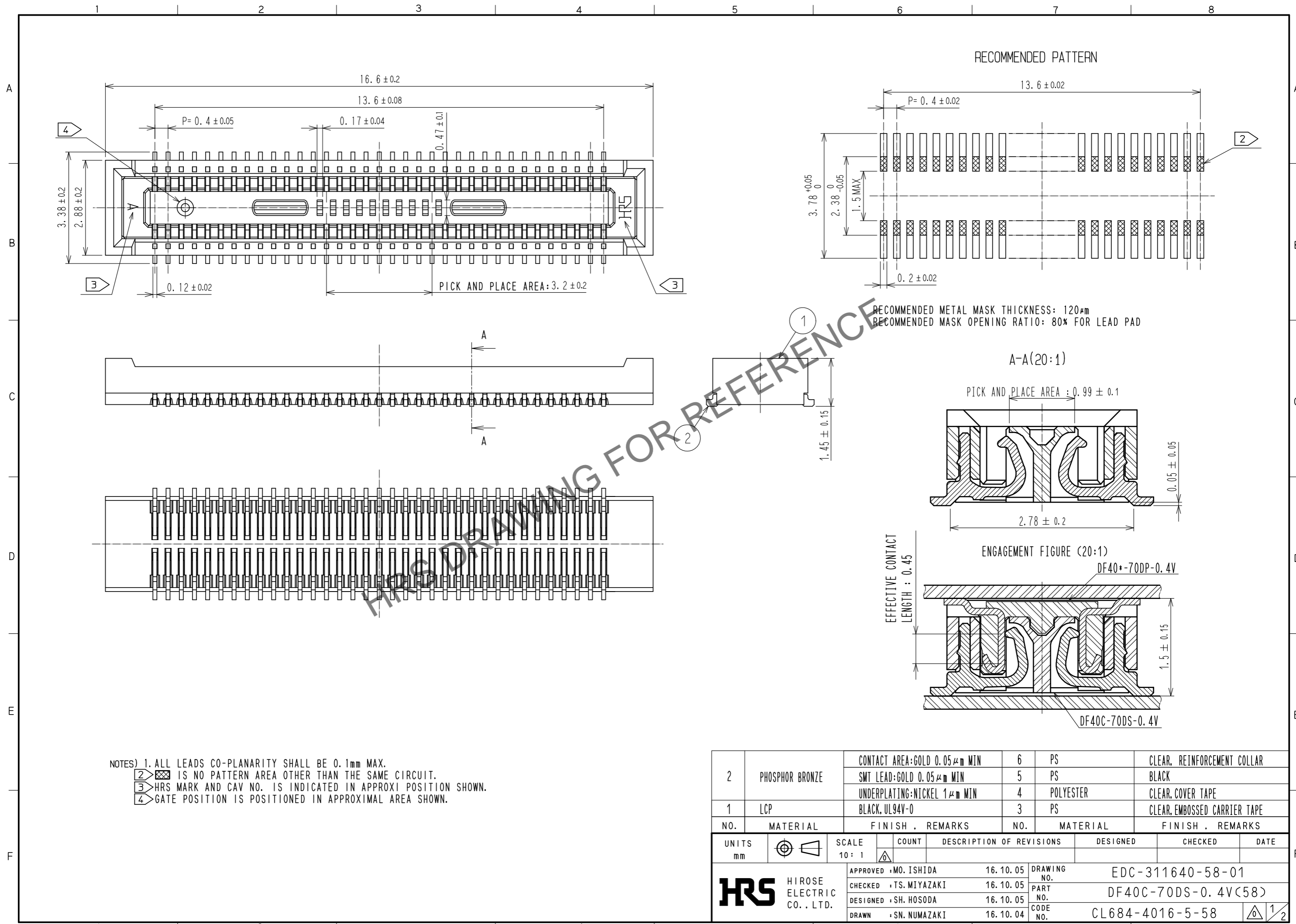

2	PHOSPHOR BRONZE	CONTACT AREA:GOLD 0.05 $\mu$ m MIN	6	PS	CLEAR, REINFORCEMENT COLLAR		
		SMT LEAD:GOLD 0.05 $\mu$ m MIN	5	PS	BLACK		
		UNDERPLATING:NICKEL 1 $\mu$ m MIN	4	POLYESTER	CLEAR, COVER TAPE		
1	LCP	BLACK, UL94V-0	3	PS	CLEAR, EMBOSSED CARRIER TAPE		
NO.	MATERIAL	FINISH . REMARKS	NO.	MATERIAL	FINISH . REMARKS		
UNITS mm		SCALE 10:1	COUNT 	DESCRIPTION OF REVISIONS	DESIGNED	CHECKED	DATE
<b>HRS</b> HIROSE ELECTRIC CO., LTD.		APPROVED :MO. ISHIDA	16.10.05	DRAWING NO.	EDC-311640-58-01		
		CHECKED :TS. MIYAZAKI	16.10.05	PART NO.	DF40C-70DS-0.4V(58)		
		DESIGNED :SH. HOSODA	16.10.05	CODE NO.	CL684-4016-5-58		
		DRAWN :SN. NUMAZAKI	16.10.04		1/2		

Mar.1.2026 Copyright 2026 HIROSE ELECTRIC CO., LTD. All Rights Reserved.  
 In case of consideration for using Automotive equipment / device which demand high reliability, kindly contact our sales window correspondents.

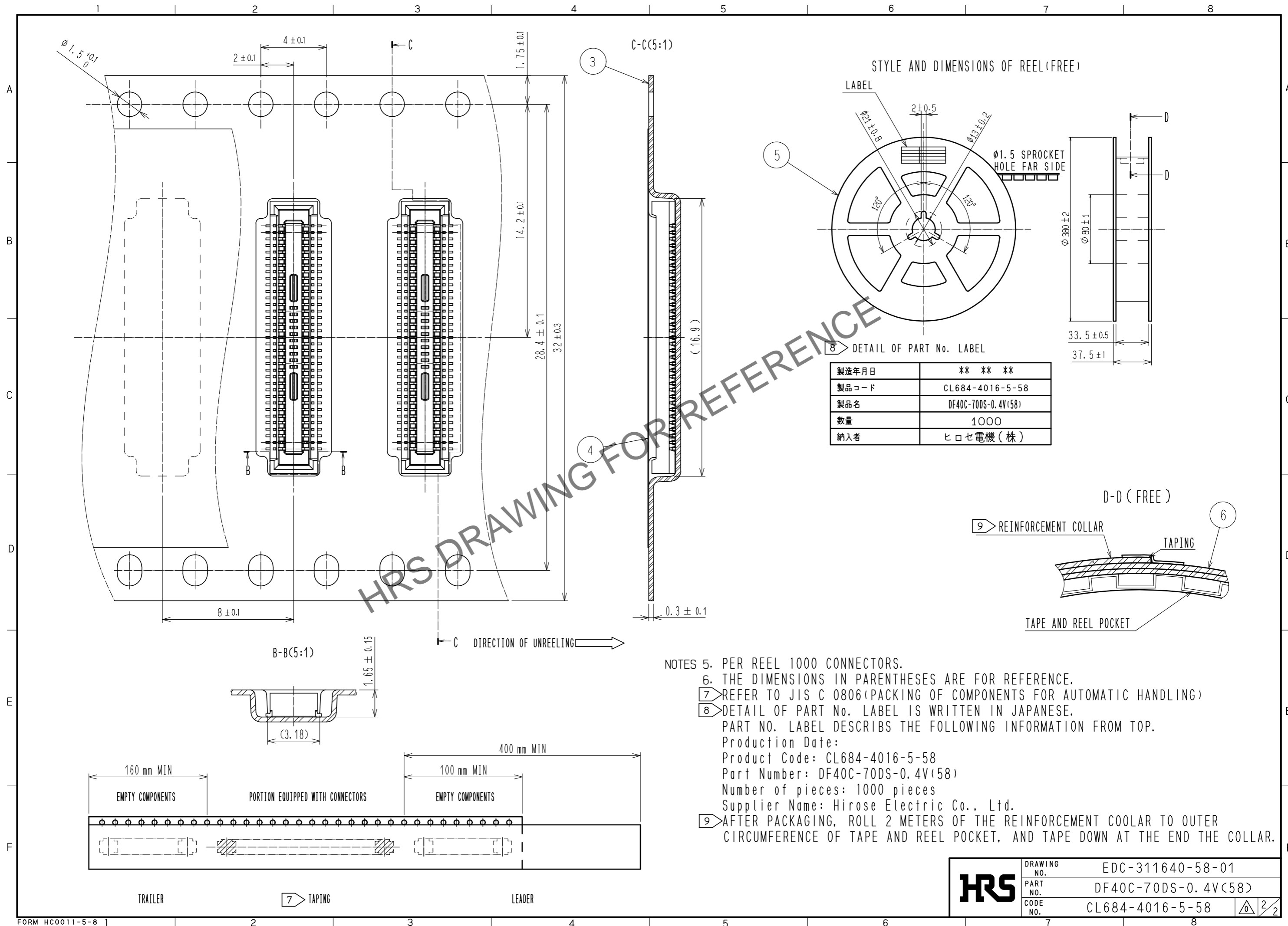

<b>HRS</b>	DRAWING NO.	EDC-311640-58-01
	PART NO.	DF40C-70DS-0.4V(58)
	CODE NO.	CL684-4016-5-58
		△ 2/2