

May.1.2024 Copyright 2024 HIROSE ELECTRIC CO., LTD. All Rights Reserved.
In case of consideration for using Automotive equipment / device which demand high reliability, kindly contact our sales window correspondents.

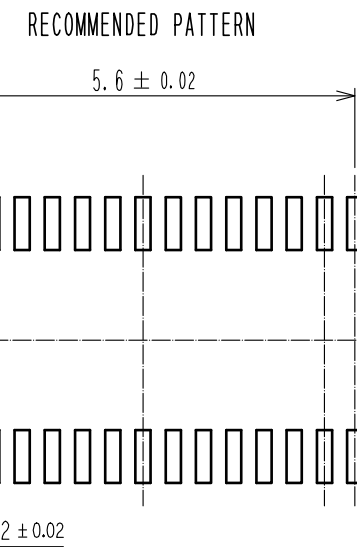

RECOMMENDED METAL MASK THICKNESS : 120 μm
RECOMMENDED METAL MASK OPENING RATIO : 80% FOR LEAD PAD

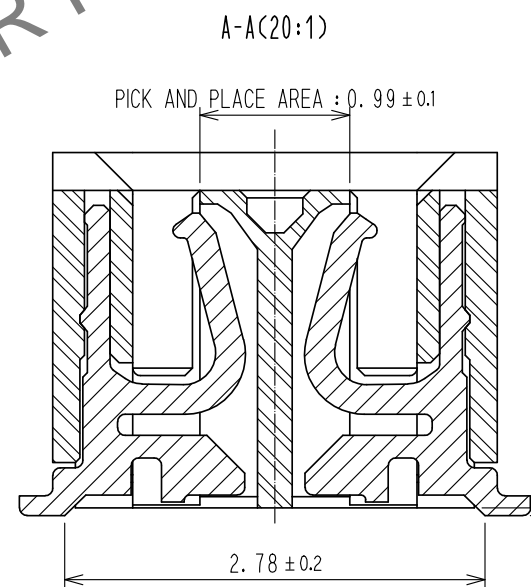
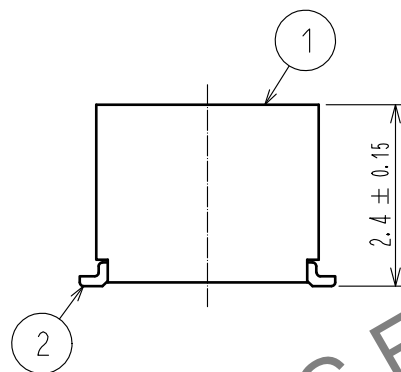
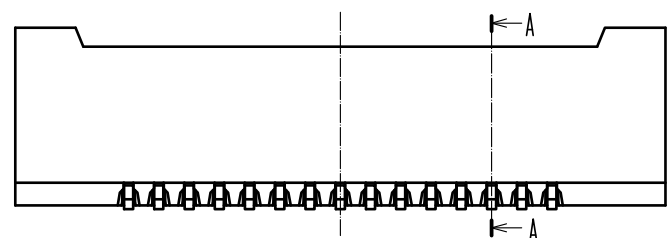
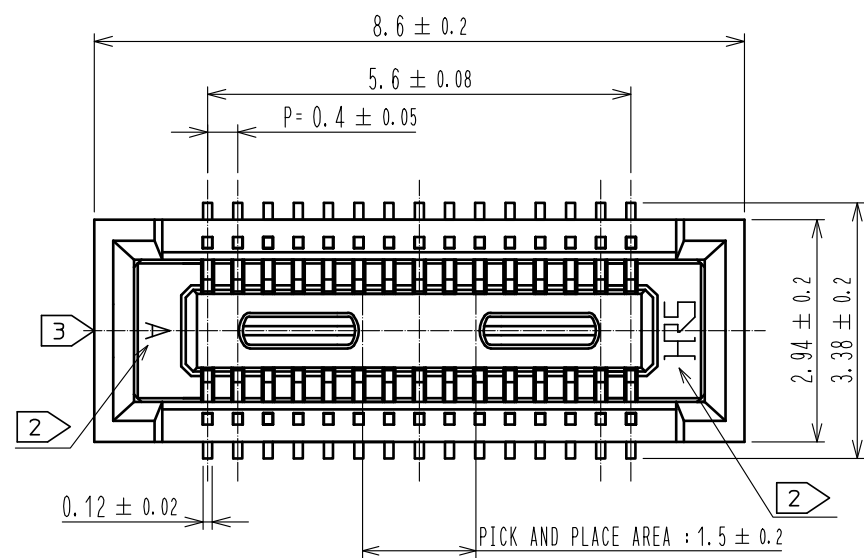
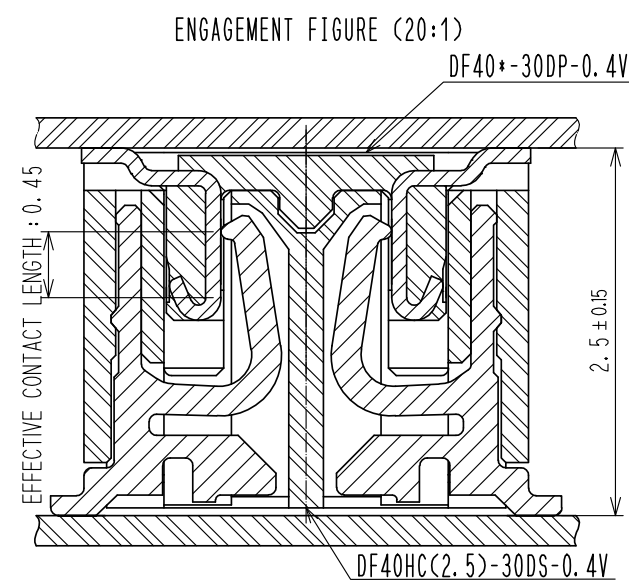

NOTE 1. ALL LEADS CO-PLANARITY SHALL BE 0.1 MAX.
 2 HRS MARK AND CAV NO. IS INDICATED IN APPROXI POSITION SHOWN.
 3 GATE POSITION IS POSITIONED IN APPROXIMAL AREA SHOWN.

2	PHOSPHOR BRONZE	CONTACT AREA: GOLD 0.05 μm MIN	5	PS	BLACK			
		SMT LEAD: GOLD 0.05 μm MIN						
		UNDERPLATING: NICKEL 1 μm MIN						
1	LCP	BLACK, UL94V-0	3	PS	CLEAR, EMBOSSED CARRIER TAPE			
NO.	MATERIAL	FINISH . REMARKS	NO.	MATERIAL	FINISH . REMARKS			
UNITS mm		SCALE 10 : 1	COUNT 3	DESCRIPTION OF REVISIONS DIS-H-00015329		DESIGNED TY. MORISHITA	CHECKED RT. SHIMIZU	DATE 20220915
HRS HIROSE ELECTRIC CO., LTD.		APPROVED : WR. FUKUCHI 20220909	DRAWING NO. EDC-319957-51-00					
		CHECKED : RT. SHIMIZU 20220909	PART NO. DF40HC(2.5)-30DS-0.4V(51)					
		DESIGNED : TY. MORISHITA 20220909	CODE NO. CL0684-4127-6-51					
		DRAWN : TY. MORISHITA 20220909						

May.1.2024 Copyright 2024 HIROSE ELECTRIC CO., LTD. All Rights Reserved.
In case of consideration for using Automotive equipment / device which demand high reliability, kindly contact our sales window correspondents.

SCALE (5:1)

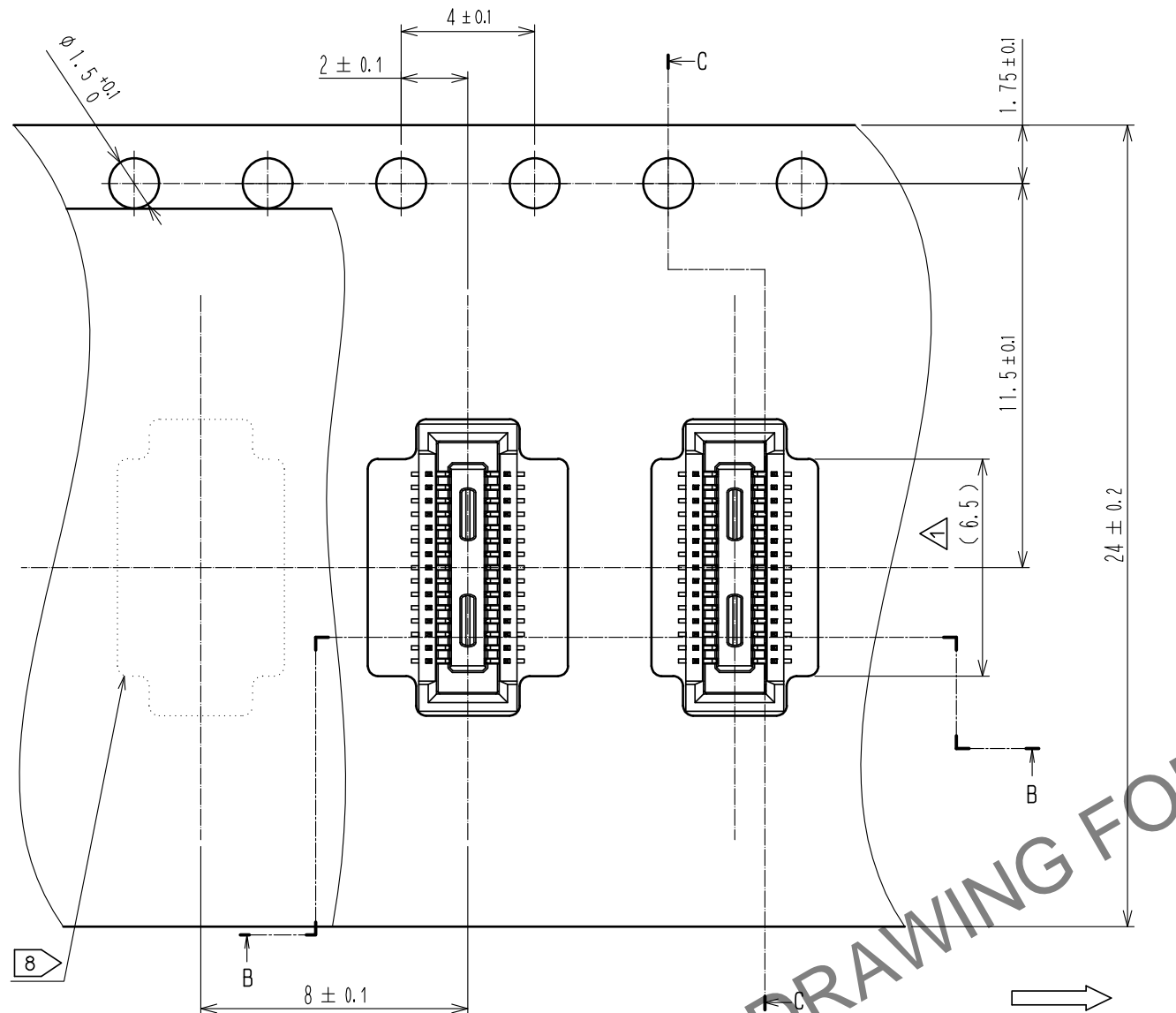

C-C(5:1)

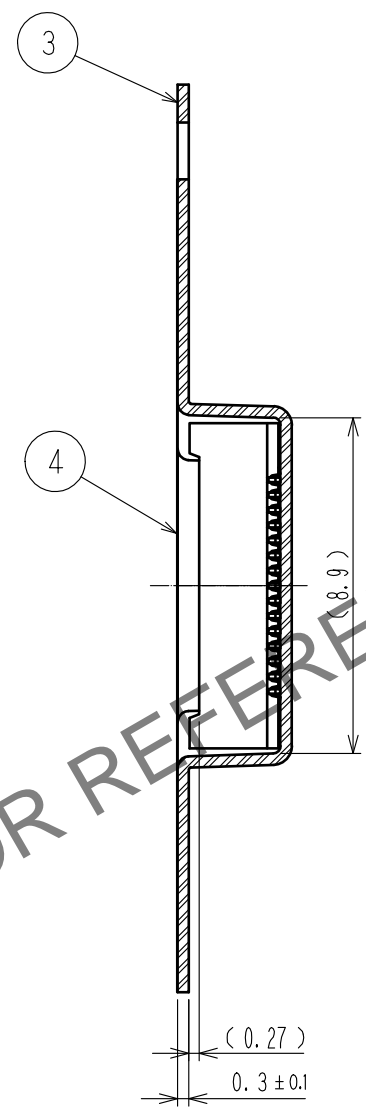

STYLE AND DIMENSION OF REEL (FREE SIZE)

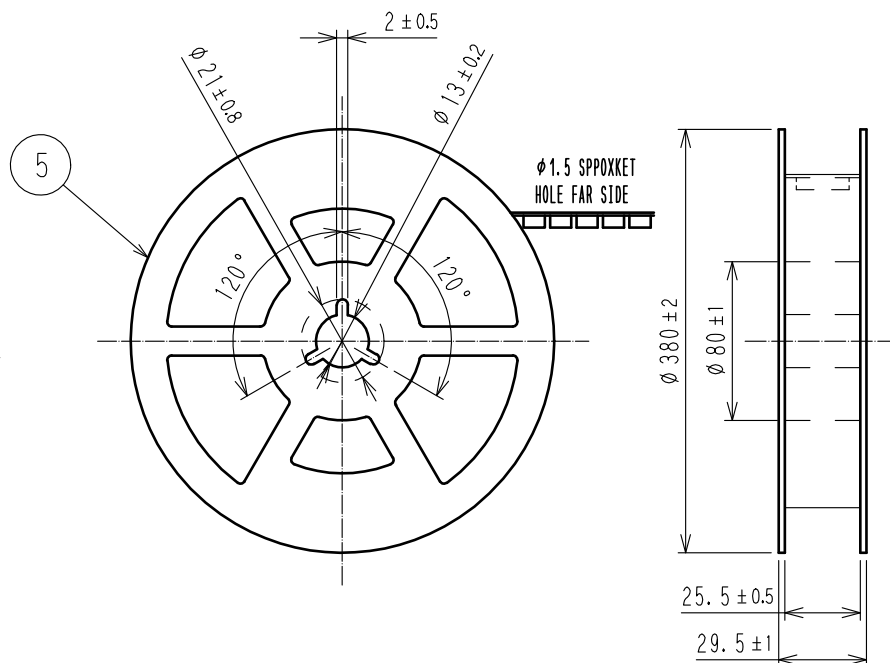

D-D(FREE)

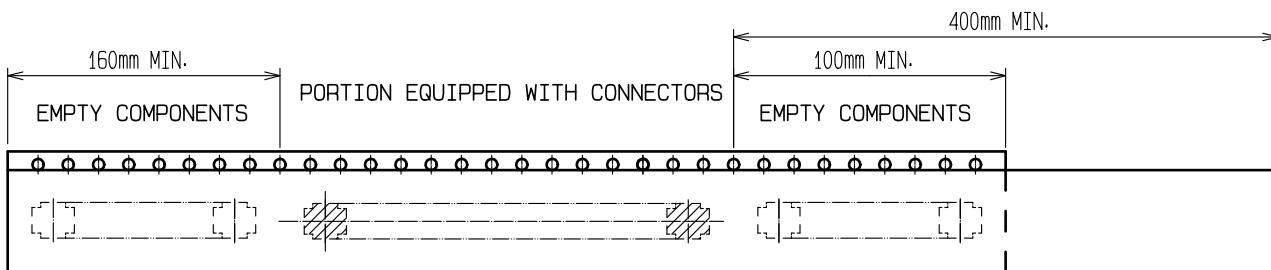
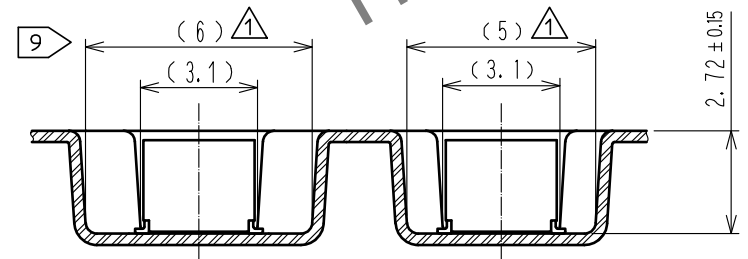
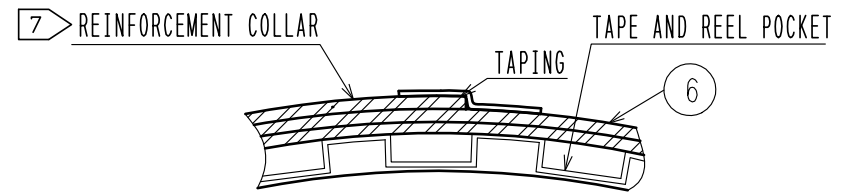

- NOTES)
- 4. PER REEL 3000 CONNECTORS.
 - 5. THE DIMENSIONS IN PARENTHESES ARE FOR REFERENCE.
 - 6 REFER TO JIS C 0806(PACKING OF COMPONENTS FOR AUTOMATIC HANDLING)
 - 7 AFTER PACKAGING. ROLL 2 METERS OF THE REINFORCEMENT COLLAR TO OUTER CIRCUMFERENCE OF TAPE AND REEL POCKET. AND TAPE DOWN AT THE END THE COLLAR.
 - 8 ONE OF SEVERAL IS DIFFERENT IN FROM OF THE EMBOSSED CARRIER TAPE TO AVOID BEING STUCK IN.

HRS	DRAWING NO.	EDC-319957-51-00
	PART NO.	DF40HC(2.5)-30DS-0.4V(51)
	CODE NO.	CL0684-4127-6-51
		2/3

May.1.2024 Copyright 2024 HIROSE ELECTRIC CO., LTD. All Rights Reserved.
In case of consideration for using Automotive equipment / device which demand high reliability, kindly contact our sales window correspondents.

9. PLEASE REFER TO THE PRODUCT GUIDELINE ETAD-H1015 FOR DETAIL OF CONNECTOR HANDLING.

THE POSITION BETWEEN THE CONNECTOR AND PAD

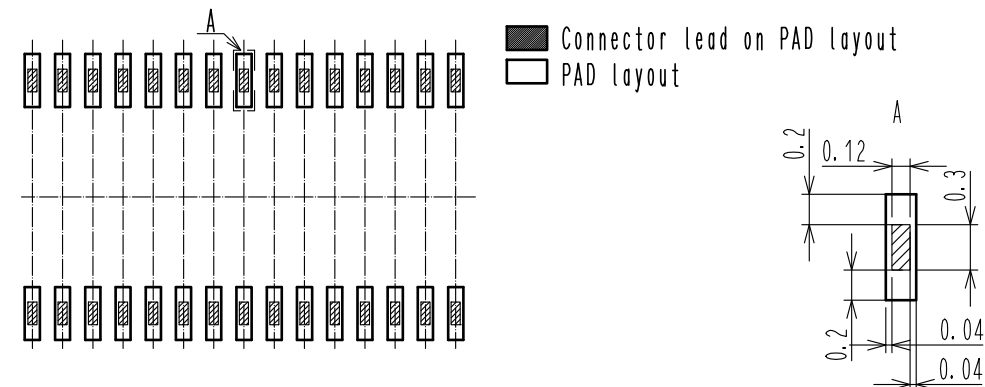

CAUTION FOR SOLDERING

THERE IS METAL EXPOSURE AREA BOTTOM OF THE CONNECTOR. TO AVOID SOLDER WICKING FROM THE BOTTOM SIDE, PLEASE DESIGN PCB PAD AND STENCIL WITH RECOMMENDED DIMENSIONS.

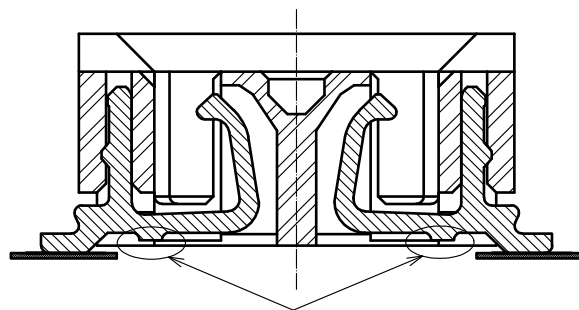

MATING METHOD

PLEASE MATE THE CONNECTOR BY HAND.

MATING PROCEDURE

- (1) FIND THE ALIGNMENT AREA TO THE CONNECTOR IN THE APPROPRIATE MATING POSITION. THIS CONNECTOR HAS AN ALIGNMENT CHAMBER (GUIDANCE RIBS) ON RECEPTACLE SIDE AND 'R' ON PLUG SIDE, SO THAT THE CONNECTOR WILL BE SELF-ALIGNED. WHEN THE CONNECTOR COMES TO THE APPROPRIATE POSITION, THE CONNECTOR GOES INTO THE ALIGNED POSITION. WHEN ALIGNED, IT CAN BE FELT BY HAND.

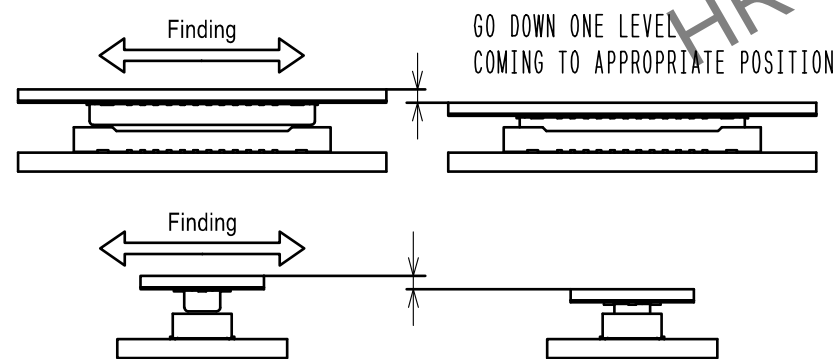

- (2) WHEN GUIDING, THE CONNECTORS ARE ALIGNED PARALLEL TO EACH OTHER, WITH LONGITUDINAL AND LATERAL MOVEMENTS RESTRICTED. MATE THEM PROPERLY BY APPLYING FORCE IN THIS CONDITION.



- (3) MAKE SURE THE CONNECTORS ARE MATED CORRECTLY. IF ONE SIDE IS FLOATING OR THE CONNECTORS ARE MATED IN ONE DIRECTION, UN-MATE THEM ONCE, AND THEN MATE THEM AGAIN, FOLLOWING THE PROCEDURES ABOVE FROM THE BEGINNING.

UN-MATING METHOD

PLEASE UN-MATE THE CONNECTOR BY HAND

- (1) UN-MATE THE CONNECTORS PARALLEL TO EACH OTHER. HOWEVER, IF THE CONNECTORS HAVE HIGH PIN COUNTS OR THINNER FPC AND STIFFENER, IT BECOMES MORE DIFFICULT TO DO SO.

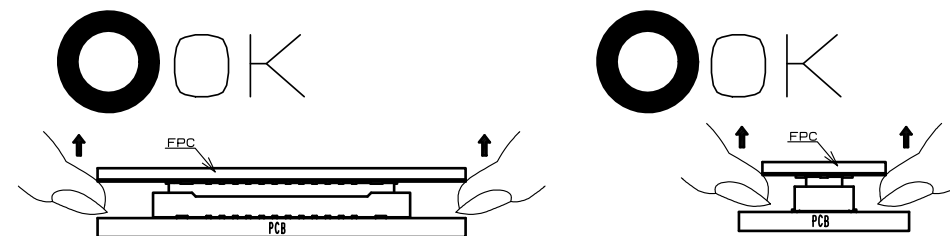

- (2) IF THE CONNECTOR CANNOT BE UN-MATED PARALLEL IT CAN BE REMOVED DIAGONALLY FROM THE PITCH DIRECTION. BE CAREFUL TO DO SO SINCE THIS ACTION APPLIES STRESS ON THE CONTACT.

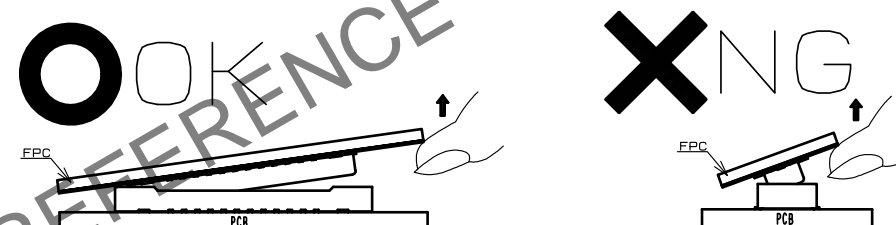

- (3) IF THE FPC IS NOT RIGID, THE CONNECTOR CAN BE BROKEN. PLEASE CHECK THE ACTION OF THE FPC TO BE USED REPEATEDLY AT THE TIME OF TRIAL PRODUCTION. BE CAREFUL TO UN-MATE THEM FROM THE PITCH DIRECTION, PULLING IT FROM THE CORNER CAN ALSO RISK TO PUTTING STRESS ON CONTACTS.

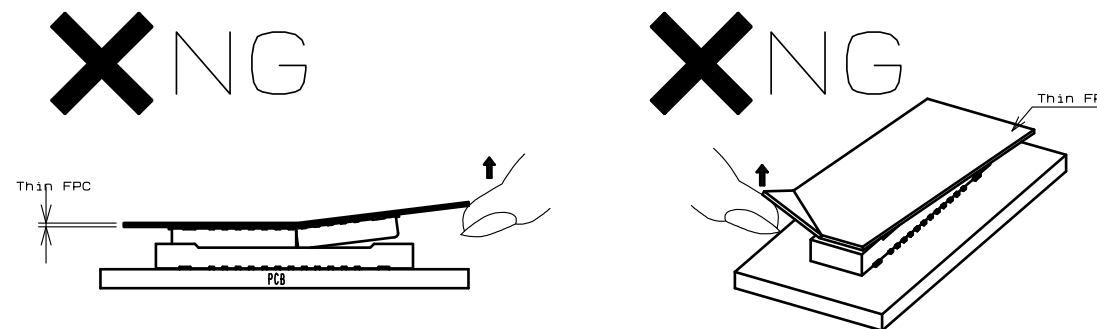

- (4) Caution for using multiple connectors.

Please avoid using more than a single mated pair of connectors between two sandwiched PCBs. Like the picture on the below. Due to possible misalignment, connector breakage while and after mating may occur.

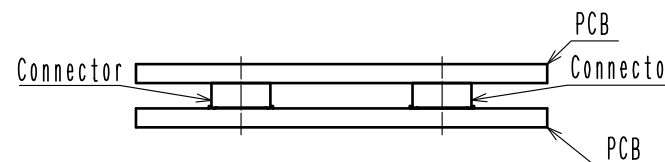

If using more than a single mated pair, please use divided boards for each connection.

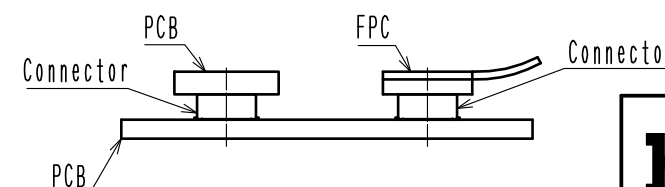

HRS	DRAWING NO.	EDC-319957-51-00
	PART NO.	DF40HC(2.5)-30DS-0.4V(51)
	CODE NO.	CL0684-4127-6-51
		3/3