

Apr.1.2024 Copyright 2024 HIROSE ELECTRIC CO., LTD. All Rights Reserved.
In case of consideration for using Automotive equipment / device which demand high reliability, kindly contact our sales window correspondents.

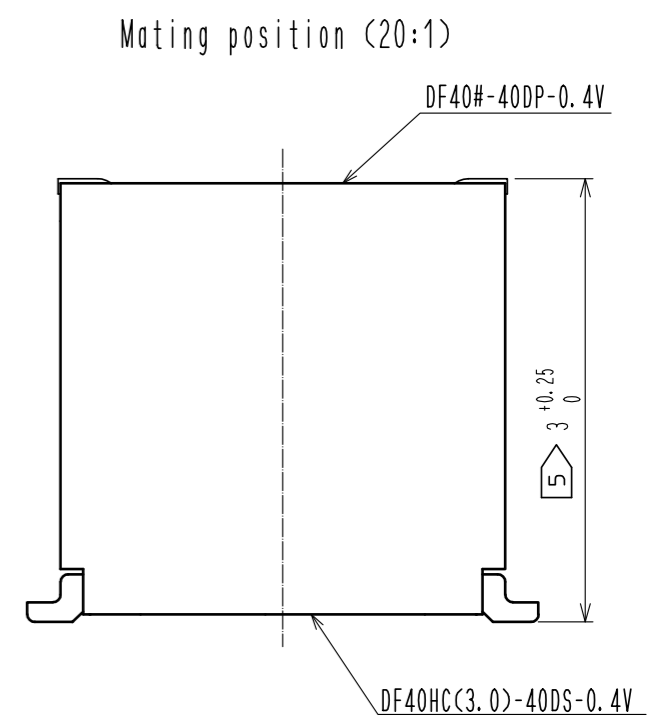
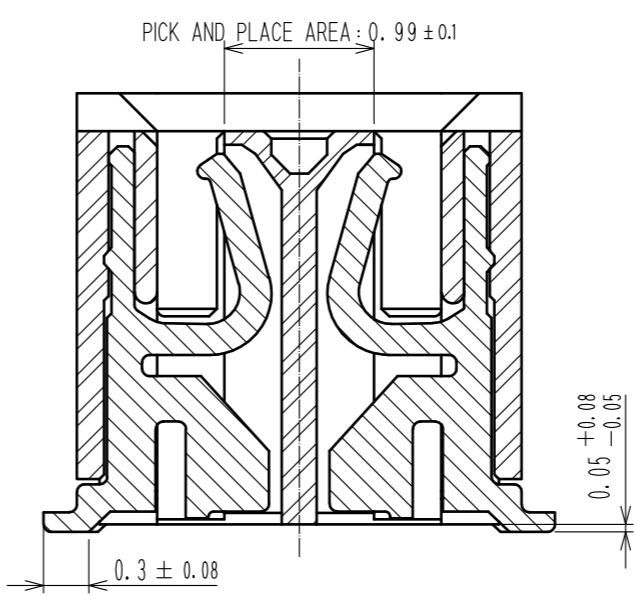
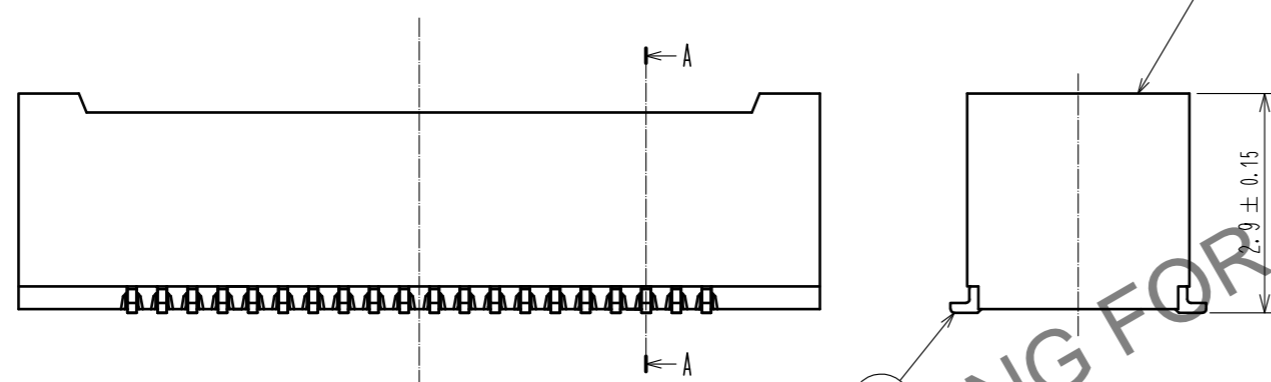
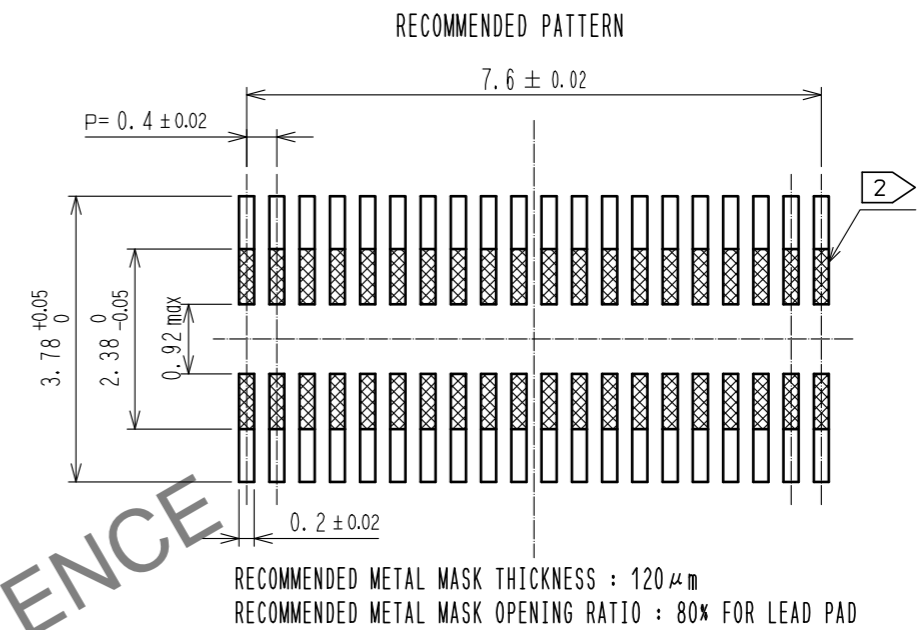
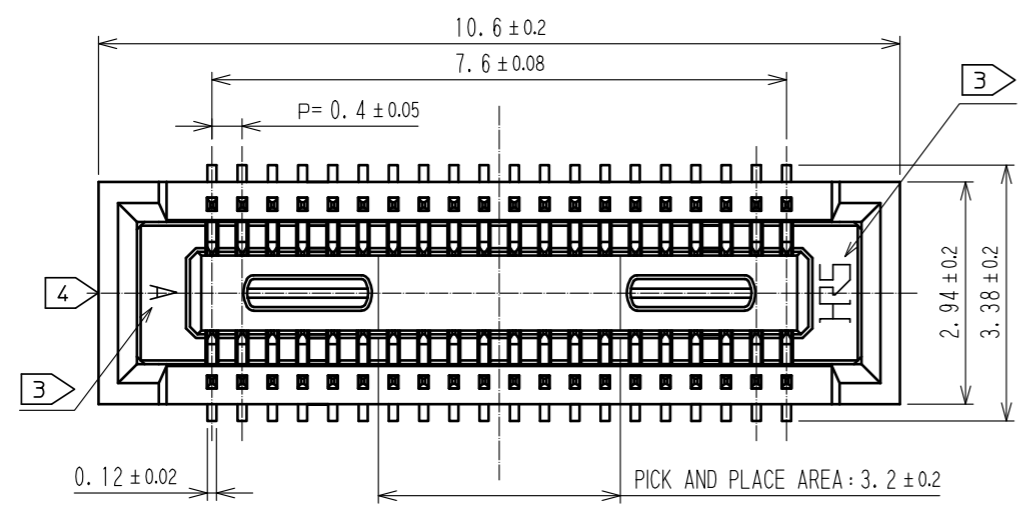

Note 1. All lead co-planarity will be 0.1mm max.
 2 is no pattern area other than the same circuit.
 3 HRS mark and cavity No. are indicated at approximate location.
 4 Gate position is indicated at approximate location.
 5 Please use the specified dimension between PCBs.

2	PHOSPHOR BRONZE	CONTACT AREA: GOLD 0.05 μm MIN	5	PS	BLACK			
		SMT LEAD: GOLD 0.05 μm MIN		4	POLYESTER	CLEAR, COVER TAPE		
		UNDERPLATING: NICKEL 1 μm MIN		3	PS	CLEAR, EMBOSSED CARRIER TAPE		
1	LCP	BLACK						
NO.	MATERIAL	FINISH . REMARKS	NO.	MATERIAL	FINISH . REMARKS			
UNITS	mm	SCALE	10 : 1	COUNT	DESCRIPTION OF REVISIONS	DESIGNED	CHECKED	DATE
		APPROVED	TY. 001	20240122	DRAWING NO. EDC-340389-58-00			
		CHECKED	RT. SHIMIZU	20240118	PART NO. DF40HC(3.0)-40DS-0.4V(58)			
		DESIGNED	YT. TAKAGI	20240118	CODE NO. CL0684-4169-6-58			
		DRAWN	YT. TAKAGI	20240118	1/3			

Apr.1.2024 Copyright 2024 HIROSE ELECTRIC CO., LTD. All Rights Reserved.
In case of consideration for using Automotive equipment / device which demand high reliability, kindly contact our sales window correspondents.

SCALE (5:1)

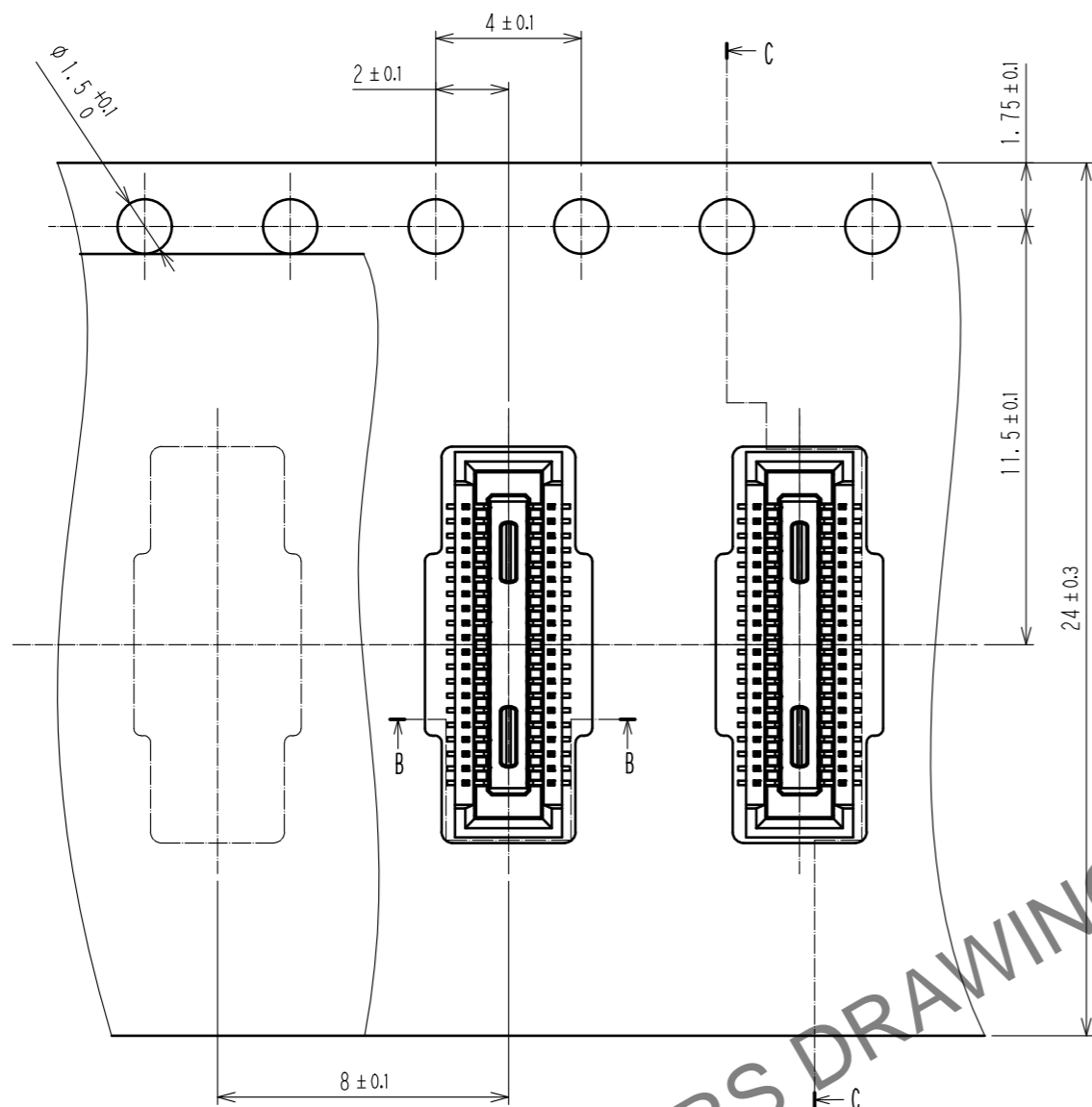

C-C(5:1)

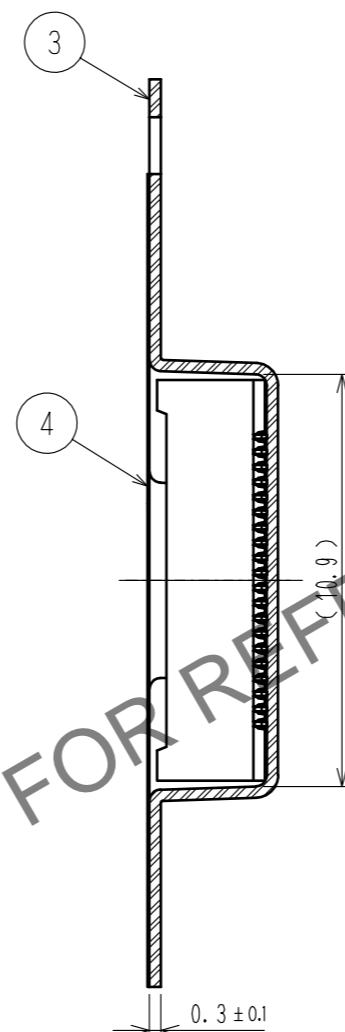

STYLE AND DIMENSION OF REEL (FREE SIZE)

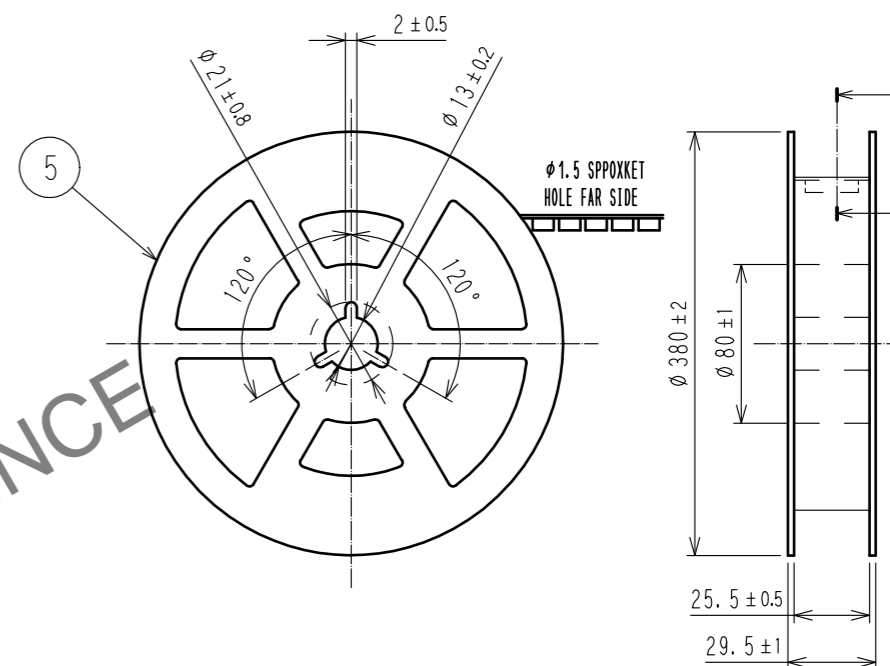

D-D (FREE)

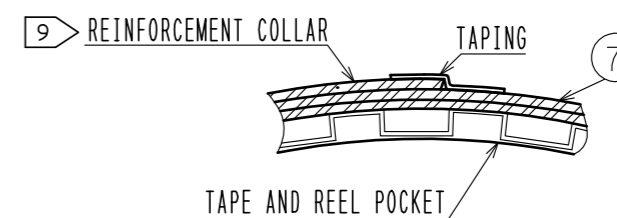

DIRECTION OF UNREELING →

B-B(5:1)

(3.68)

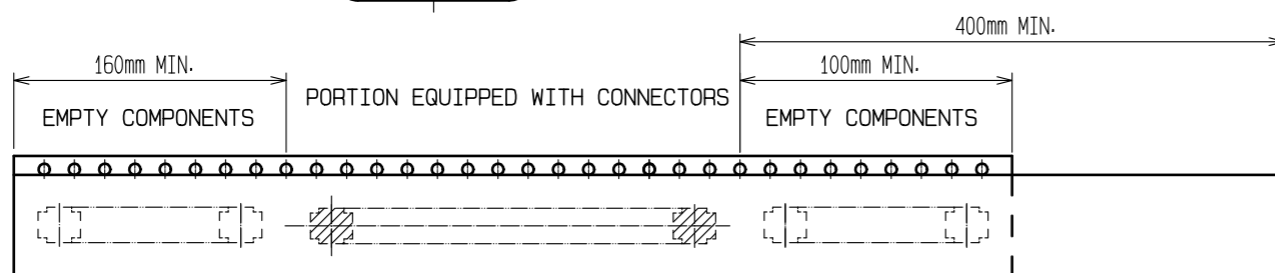
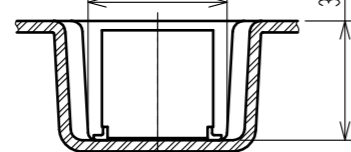

- Notes)
6. 1000 connectors per reel.
 7. The dimensions in parentheses are only for reference.
 8. Refer to iec 60286-3 (packaging of components for automatic handling)
 9. The reinforcing collar is wrapped around the emboss tape and taped down at the end of the collar.
 10. Product reels and packaging will be clearly labeled with the part number, lot number and quantity.

HRS

DRAWING NO.	EDC-340389-58-00
PART NO.	DF40HC(3.0)-40DS-0.4V(58)
CODE NO.	CL0684-4169-6-58

2/3

Apr.1.2024 Copyright 2024 HIROSE ELECTRIC CO., LTD. All Rights Reserved.
In case of consideration for using Automotive equipment / device which demand high reliability, kindly contact our sales window correspondents.

11. PLEASE REFER TO THE PRODUCT GUIDELINE ETAD-H1015 FOR DETAIL OF CONNECTOR HANDLING.

THE POSITION BETWEEN THE CONNECTOR AND PAD

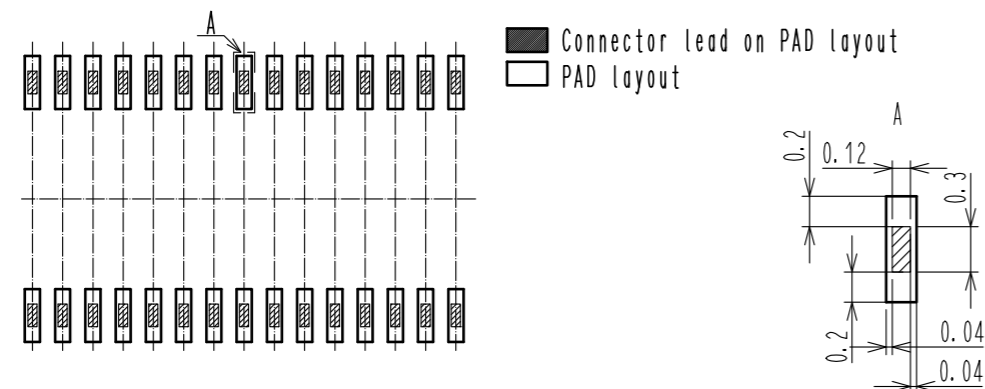

CAUTION FOR SOLDERING

THERE IS METAL EXPOSURE AREA BOTTOM OF THE CONNECTOR. TO AVOID SOLDER WICKING FROM THE BOTTOM SIDE, PLEASE DESIGN PCB PAD AND STENCIL WITH RECOMMENDED DIMENSIONS.

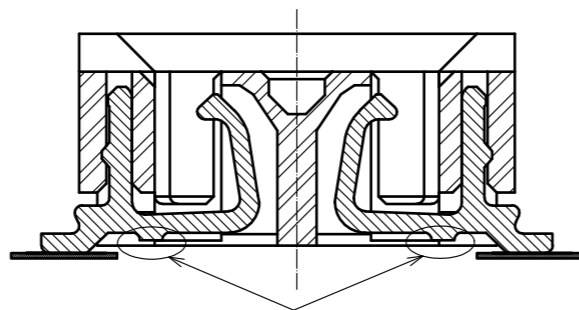

MATING METHOD

PLEASE MATE THE CONNECTOR BY HAND.

MATING PROCEDURE

- (1) FIND THE ALIGNMENT AREA TO THE CONNECTOR IN THE APPROPRIATE MATING POSITION. THIS CONNECTOR HAS AN ALIGNMENT CHAMBER(GUIDANCE RIBS) ON RECEPTACLE SIDE AND 'R' ON PLUG SIDE, SO THAT THE CONNECTOR WILL BE SELF-ALIGNED. WHEN THE CONNECTOR COMES TO THE APPROPRIATE POSITION, THE CONNECTOR GOES INTO THE ALIGNED POSITION. WHEN ALIGNED, IT CAN BE FELT BY HAND.

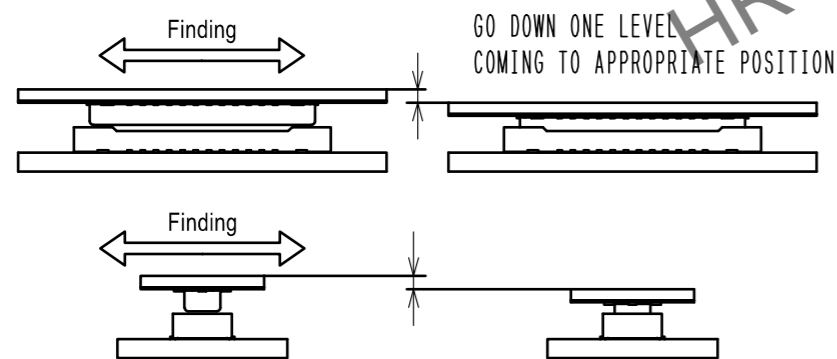

- (2) WHEN GUIDING, THE CONNECTORS ARE ALIGNED PARALLEL TO EACH OTHER, WITH LONGITUDINAL AND LATERAL MOVEMENTS RESTRICTED. MATE THEM PROPERLY BY APPLYING FORCE IN THIS CONDITION.



- (3) MAKE SURE THE CONNECTORS ARE MATED CORRECTLY. IF ONE SIDE IS FLOATING OR THE CONNECTORS ARE MATED IN ONE DIRECTION, UN-MATE THEM ONCE, AND THEN MATE THEM AGAIN, FOLLOWING THE PROCEDURES ABOVE FROM THE BEGINNING.

UN-MATING METHOD

PLEASE UN-MATE THE CONNECTOR BY HAND

- (1) UN-MATE THE CONNECTORS PARALLEL TO EACH OTHER. HOWEVER, IF THE CONNECTORS HAVE HIGH PIN COUNTS OR THINNER FPC AND STIFFENER, IT BECOMES MORE DIFFICULT TO DO SO.

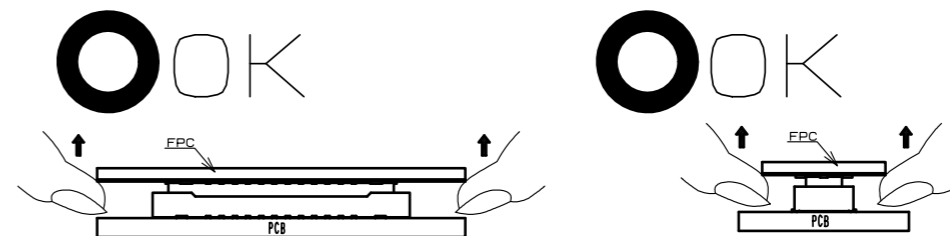

- (2) IF THE CONNECTOR CANNOT BE UN-MATED PARALLEL IT CAN BE REMOVED DIAGONALLY FROM THE PITCH DIRECTION. BE CAREFUL TO DO SO SINCE THIS ACTION APPLIES STRESS ON THE CONTACT.



- (3) IF THE FPC IS NOT RIGID, THE CONNECTOR CAN BE BROKEN. PLEASE CHECK THE ACTION OF THE FPC TO BE USED REPEATEDLY AT THE TIME OF TRIAL PRODUCTION. BE CAREFUL TO UN-MATE THEM FROM THE PITCH DIRECTION, PULLING IT FROM THE CORNER CAN ALSO RISK TO PUTTING STRESS ON CONTACTS.

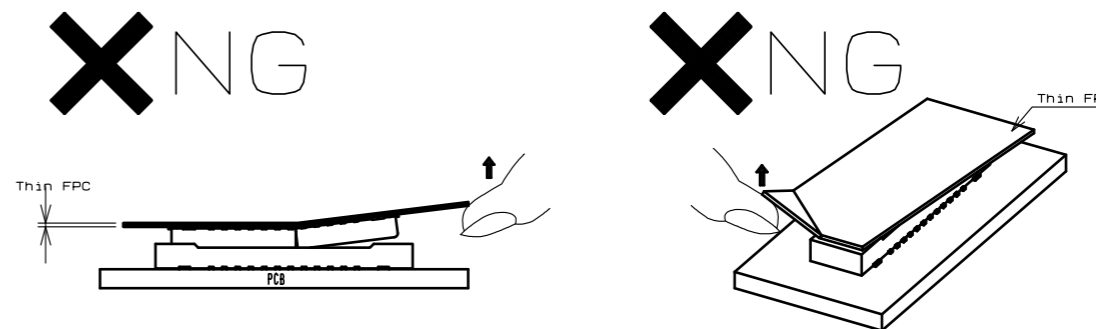

- (4) Caution for using multiple connectors.

Please avoid using more than a single mated pair of connectors between two sandwiched PCBs. Like the picture on the below. Due to possible misalignment, connector breakage while and after mating may occur.

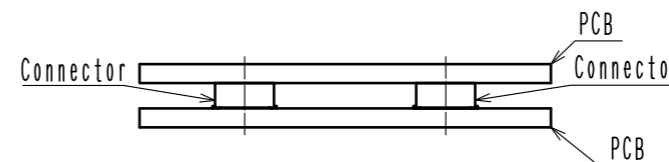

If using more than a single mated pair, please use divided boards for each connection.

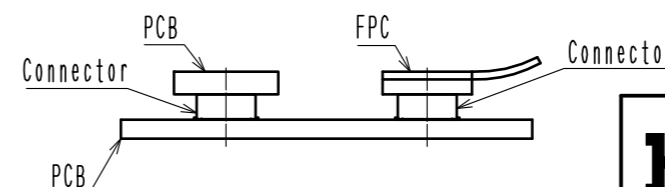

HRS	DRAWING NO.	EDC-340389-58-00
	PART NO.	DF40HC(3.0)-40DS-0.4V(58)
	CODE NO.	CL0684-4169-6-58
		3/3