

Oct.1.2024 Copyright 2024 HIROSE ELECTRIC CO., LTD. All Rights Reserved.
 In case of consideration for using Automotive equipment / device which demand high reliability, kindly contact our sales window correspondents.

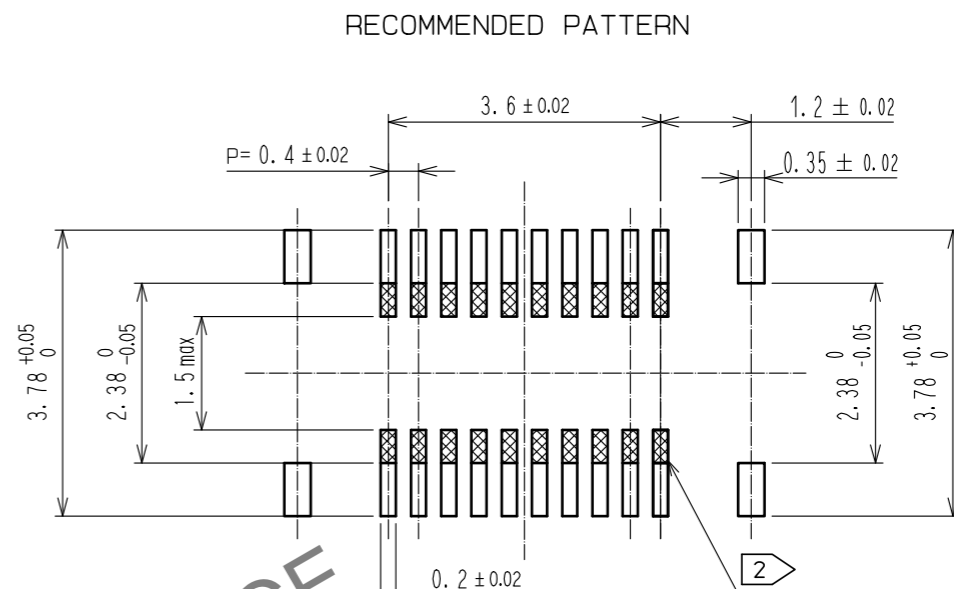

RECOMMENDED METAL MASK THICKNESS : 120µm
 RECOMMENDED METAL MASK OPENING RATIO : 80% FOR LEAD PAD

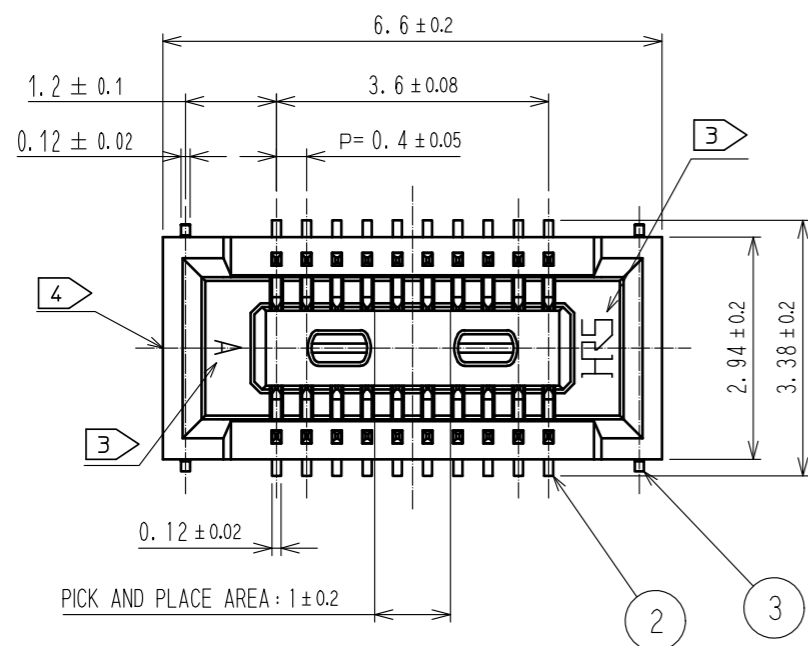
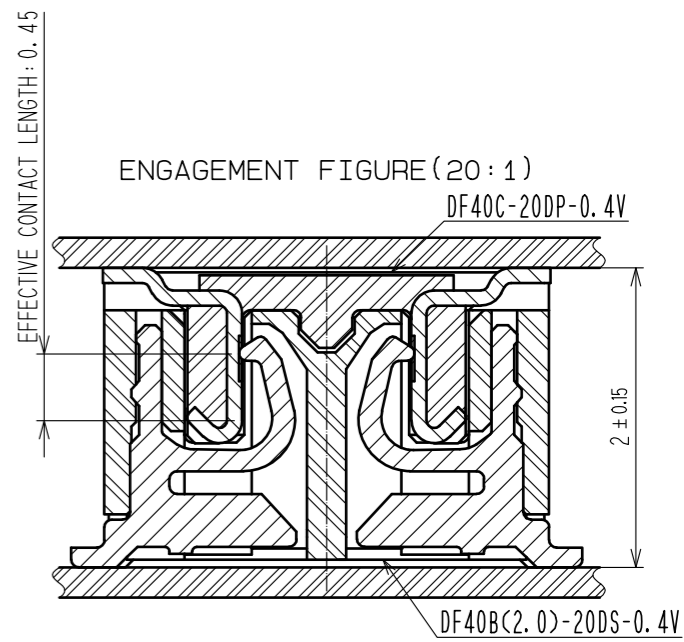
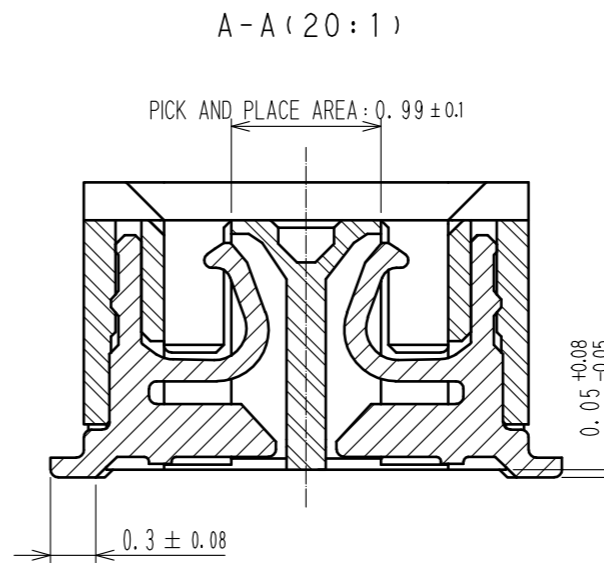
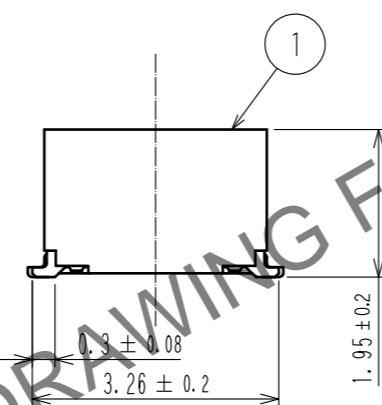
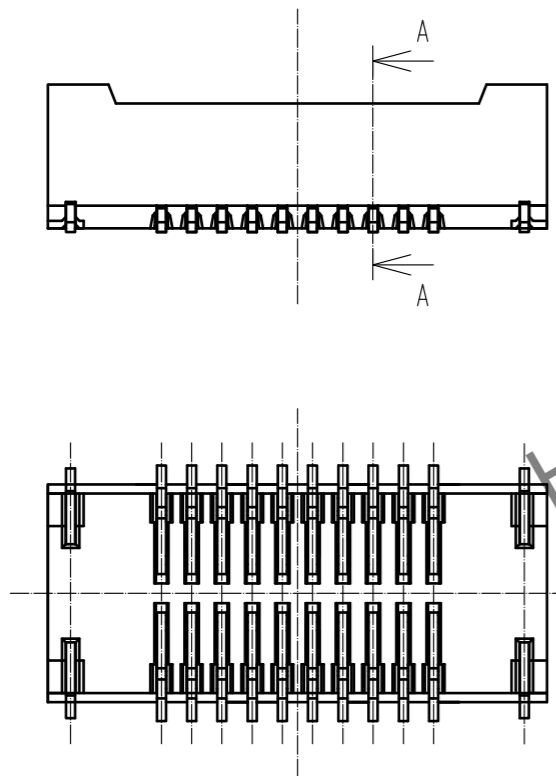

- NOTES) 1. ALL LEADS AND REINFORCED METAL FITTINGS CO-PLANARITY SHALL BE 0.1MAX.
 2. IS NO PATTERN AREA OTHER THAN THE SAME CIRCUIT.
 3. HRS MARK AND CAV NO. ARE LOCATED IN APPROXIMAL AREA.
 4. GATE POSITIONS IS LOCATED IN APPROXIMAL AREA.
 A PART OF THE WALL MAY BE NOTCHED FOR SETTING GATE.

2	PHOSPHOR BRONZE	CONTACT AREA: GOLD 0.1µm MIN SMT LEAD: GOLD 0.05µm MIN UNDERPLATING: NICKEL 1µm MIN	7	PS	CLEAR, REINFORCEMENT COLLAR
1	LCP	UL94V-0, BLACK	6	PS	BLACK, PLASTIC REEL
			5	POLYESTER	CLEAR, COVER TAPE
			4	PS	CLEAR, EMBOSSED CARRIER TAPE
			3	PHOSPHOR BRONZE	SURFACE: GOLD 0.05µm MIN UNDERPLATING: NICKEL 1µm MIN
NO.	MATERIAL	FINISH, REMARKS	NO.	MATERIAL	FINISH, REMARKS
UNITS mm		SCALE 10:1	COUNT	DESCRIPTION OF REVISIONS	
HIROSE ELECTRIC CO., LTD.		APPROVED : WR. FUKUCHI 20200220	DESIGNED	EDC-354974-75-02	
		CHECED : TS. MIYAZAKI 20200220	CHECKED	DF40B(2.0)-20DS-0.4V(75)	
		DESIGNED : RH. KAGAMI 20200220	DATE	CL684-4213-6-75	
		DRAWN : RH. KAGAMI 20200220		1/2	

Oct.1.2024 Copyright 2024 HIROSE ELECTRIC CO., LTD. All Rights Reserved.
 In case of consideration for using Automotive equipment / device which demand high reliability, kindly contact our sales window correspondents.

EMBOSSED CARRIER TAPE DIMENSIONS (5:1)

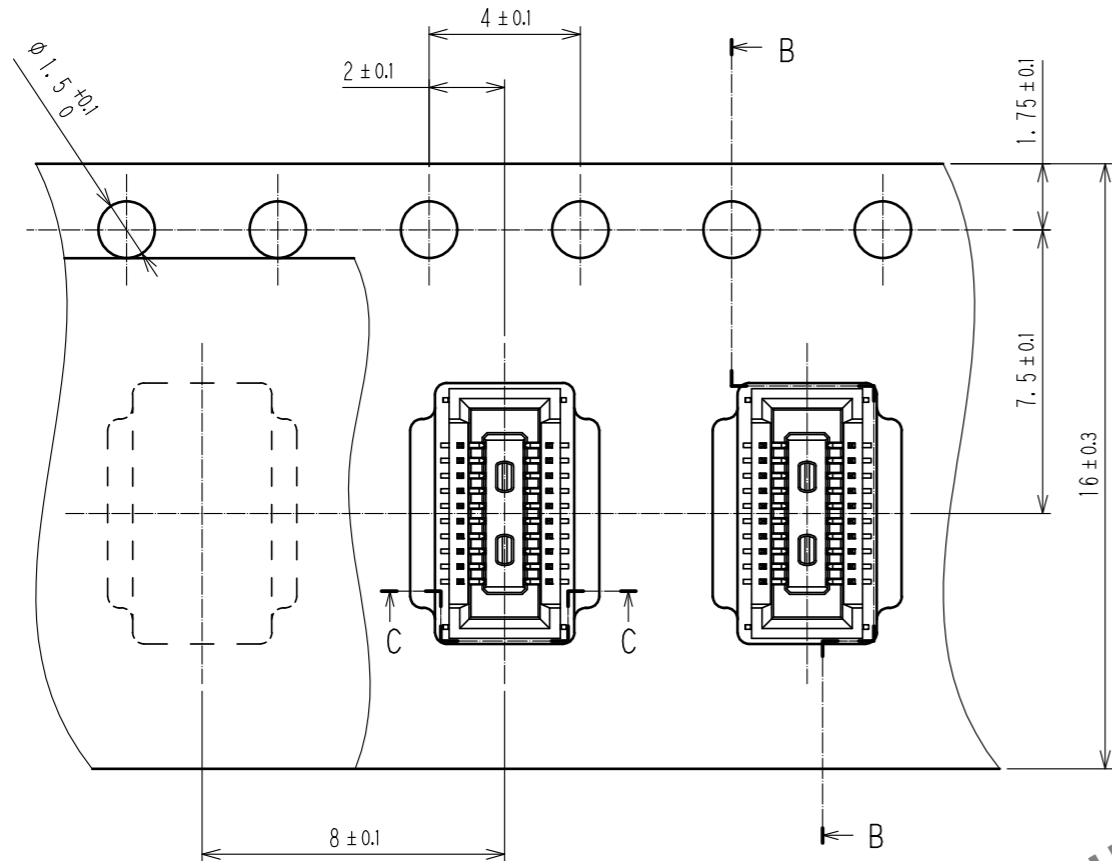

DIRECTION OF UNREELING

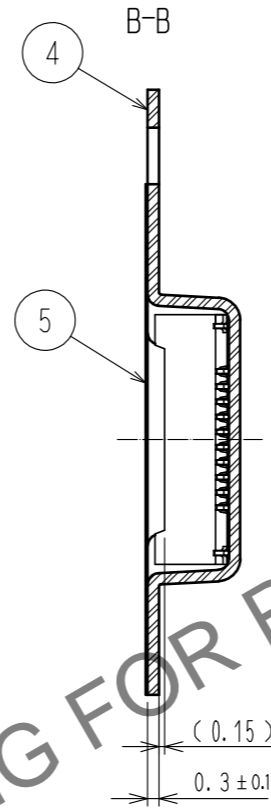
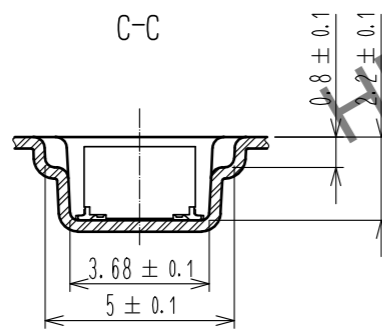

STYLE AND DIMENSION OF REEL (FREE)

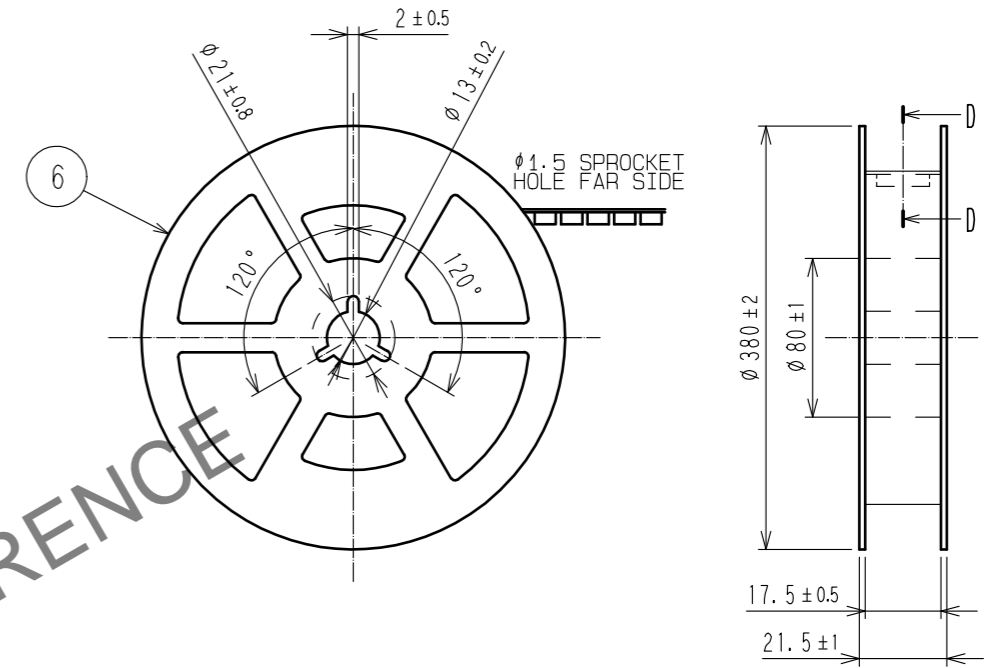

D-D(FREE)

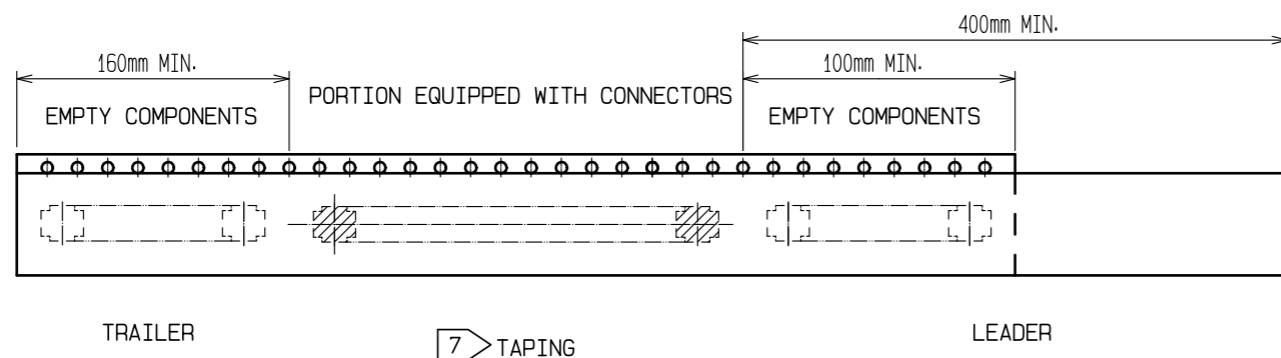
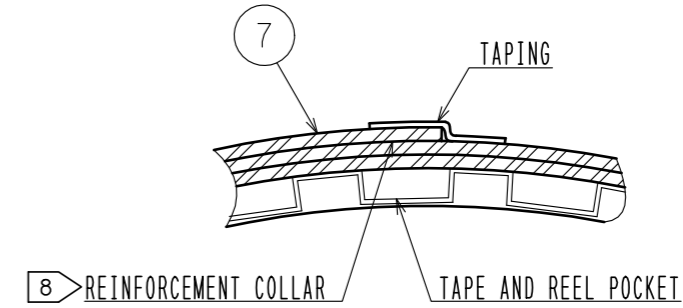

- NOTES) 5. PER REEL 4000 CONNECTORS.
 6. THE DIMENSIONS IN PARENTHESES ARE FOR REFERENCE.
 7 REFER TO JIS C 0806(IEC 60286-3)(PACKING OF COMPONENTS FOR AUTOMATIC HANDLING)
 8 AFTER PACKAGING, ROLL 2 METERS OF THE REINFORCEMENT COLLAR TO OUTER CIRCUMFERENCE OF TAPE AND REEL POCKET. AND TAPE DOWN AT THE END THE COLLAR.

HRS	DRAWING NO.	EDC-354974-75-02
	PART NO.	DF40B(2.0)-20DS-0.4V(75)
	CODE NO.	CL684-4213-6-75
		2/2