

Oct.1.2024 Copyright 2024 HIROSE ELECTRIC CO., LTD. All Rights Reserved.  
 In case of consideration for using Automotive equipment / device which demand high reliability, kindly contact our sales window correspondents.

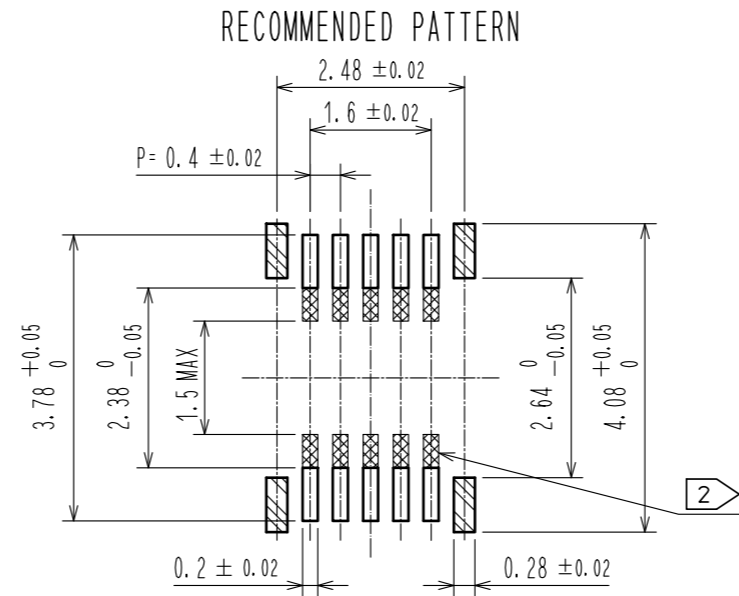

□ : SIGNAL    ▨ : GROUND    ▩ : NON-CONDUCTIVE AREA

RECOMMENDED METAL MASK THICKNESS : 120 μm  
 RECOMMENDED MASK OPENING RATIO : 80% FOR LEAD PAD

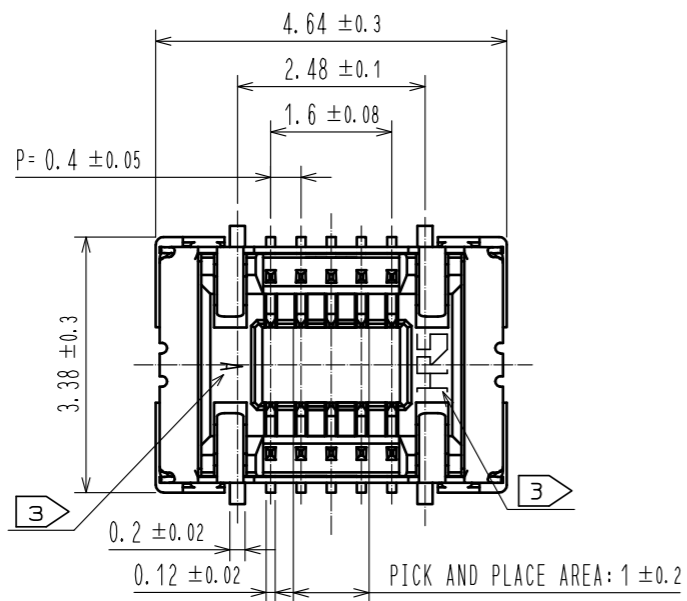
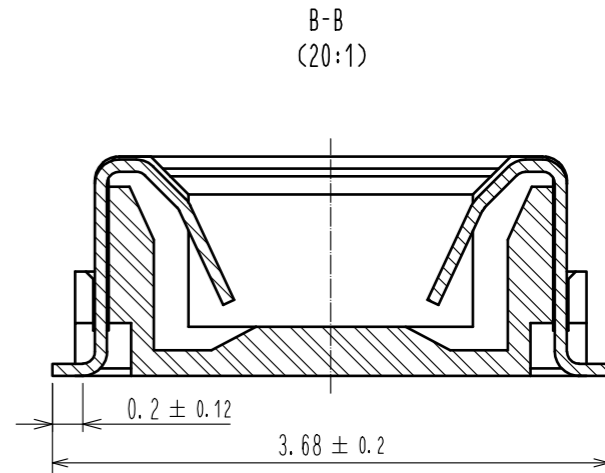
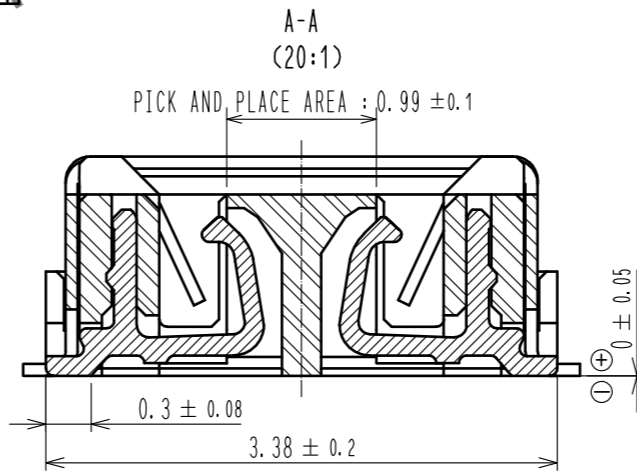
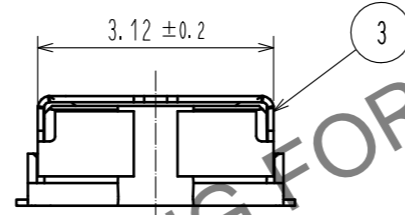
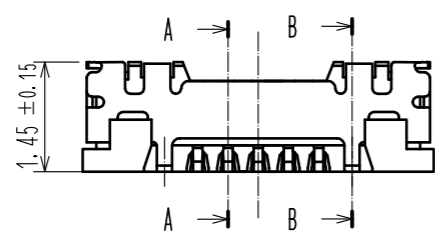
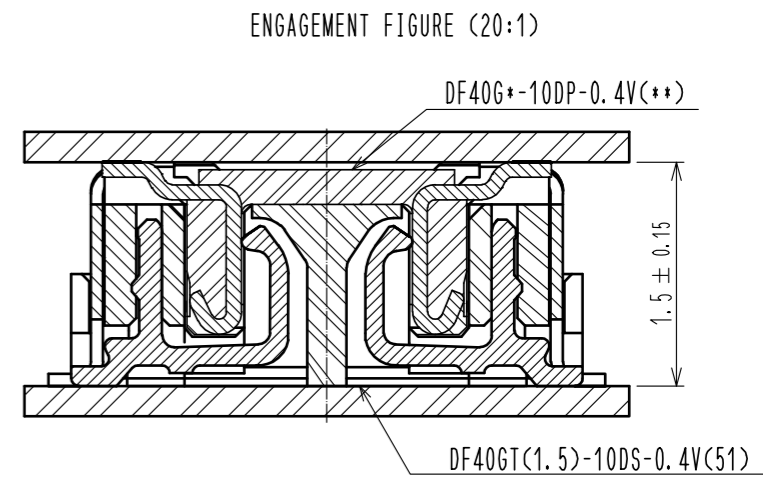

NOTE 1. ALL LEADS CO-PLANARITY SHALL BE 0.1 MAX.  
 2 ▩ IS NO PATTERN AREA OTHER THAN THE SAME CIRCUIT.  
 3 HRS MARK AND CAV NO. ARE INDICATED IN APPROX. POSITION SHOWN.

NO.	MATERIAL	FINISH	REMARKS	NO.	MATERIAL	FINISH	REMARKS
3	COPPER ALLOY	GOLD 0.05μm MIN	UNDERPLATING-NICKEL 1μm MIN	7	PS		CLEAR-REINFORCEMENT COLLAR
2	COPPER ALLOY	GOLD 0.05μm MIN	UNDERPLATING-NICKEL 1μm MIN	6	PS		BLACK-PLASTIC REEL
				5	POLYESTER		CLEAR-COVER TAPE
1	LCP	UL94V-0	BLACK	4	PS		CLEAR(EMBOSSED CARRIER TAPE)

  

UNITS	SCALE	COUNT	DESCRIPTION OF REVISIONS	DESIGNED	CHECKED	DATE
mm	10:1	0				

APPROVED	CHECKED	DESIGNED	DRAWN	DATE	DRAWING NO.	PART NO.	CODE NO.
WR. FUKUCHI	YK. SATAKE	PAN YIWEI	PAN YIWEI	20201222	EDC-384225-51-01	DF40GT(1.5)-10DS-0.4V(51)	CL0684-4248-0-51

Oct.1.2024 Copyright 2024 HIROSE ELECTRIC CO., LTD. All Rights Reserved.  
 In case of consideration for using Automotive equipment / device which demand high reliability, kindly contact our sales window correspondents.

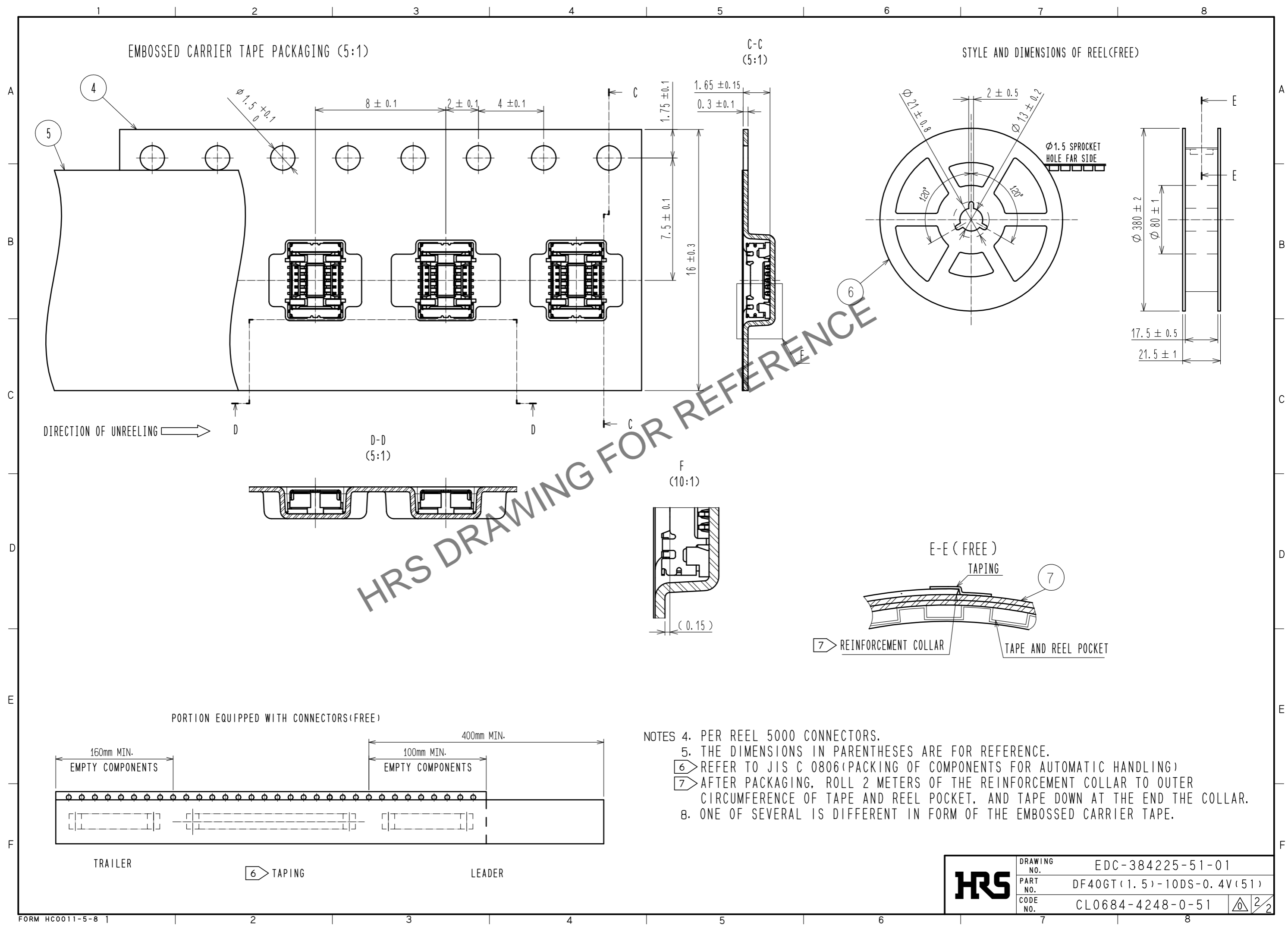

HRS DRAWING FOR REFERENCE

- NOTES
4. PER REEL 5000 CONNECTORS.
  5. THE DIMENSIONS IN PARENTHESES ARE FOR REFERENCE.
  6. REFER TO JIS C 0806(PACKING OF COMPONENTS FOR AUTOMATIC HANDLING)
  7. AFTER PACKAGING, ROLL 2 METERS OF THE REINFORCEMENT COLLAR TO OUTER CIRCUMFERENCE OF TAPE AND REEL POCKET, AND TAPE DOWN AT THE END THE COLLAR.
  8. ONE OF SEVERAL IS DIFFERENT IN FORM OF THE EMBOSED CARRIER TAPE.

<b>HRS</b>	DRAWING NO.	EDC-384225-51-01
	PART NO.	DF40GT(1.5)-10DS-0.4V(51)
	CODE NO.	CL0684-4248-0-51
		2/2