

Oct.1.2024 Copyright 2024 HIROSE ELECTRIC CO., LTD. All Rights Reserved.
 In case of consideration for using Automotive equipment / device which demand high reliability, kindly contact our sales window correspondents.

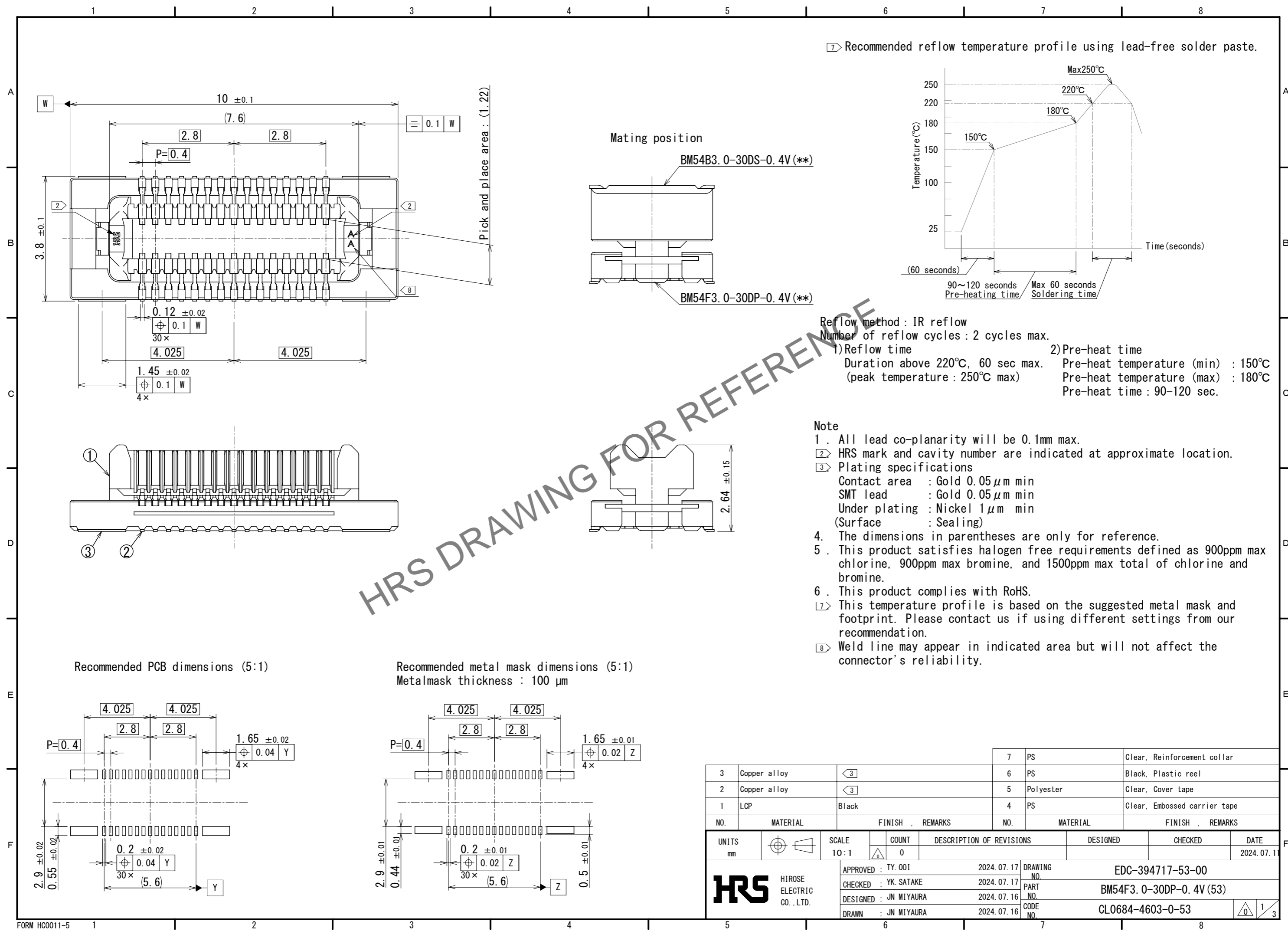

3	Copper alloy	\triangleleft 3	7	PS	Clear, Reinforcement collar			
2	Copper alloy	\triangleleft 3	6	PS	Black, Plastic reel			
1	LCP	Black	5	Polyester	Clear, Cover tape			
			4	PS	Clear, Embossed carrier tape			
NO.	MATERIAL	FINISH	REMARKS	NO.	MATERIAL	FINISH	REMARKS	
UNITS	\odot	SCALE	COUNT	DESCRIPTION OF REVISIONS		DESIGNED	CHECKED	DATE
mm		10:1	0					2024.07.11
APPROVED: TY. OOI		2024.07.17		DRAWING NO.		EDC-394717-53-00		
CHECKED: YK. SATAKE		2024.07.17		PART NO.		BM54F3. 0-30DP-0.4V (53)		
DESIGNED: JN. MIYaura		2024.07.16		CODE NO.		CL0684-4603-0-53		
DRAWN: JN. MIYaura		2024.07.16						



Oct.1.2024 Copyright 2024 HIROSE ELECTRIC CO., LTD. All Rights Reserved.
 In case of consideration for using Automotive equipment / device which demand high reliability, kindly contact our sales window correspondents.

Embossed carrier tape packaging (5:1)

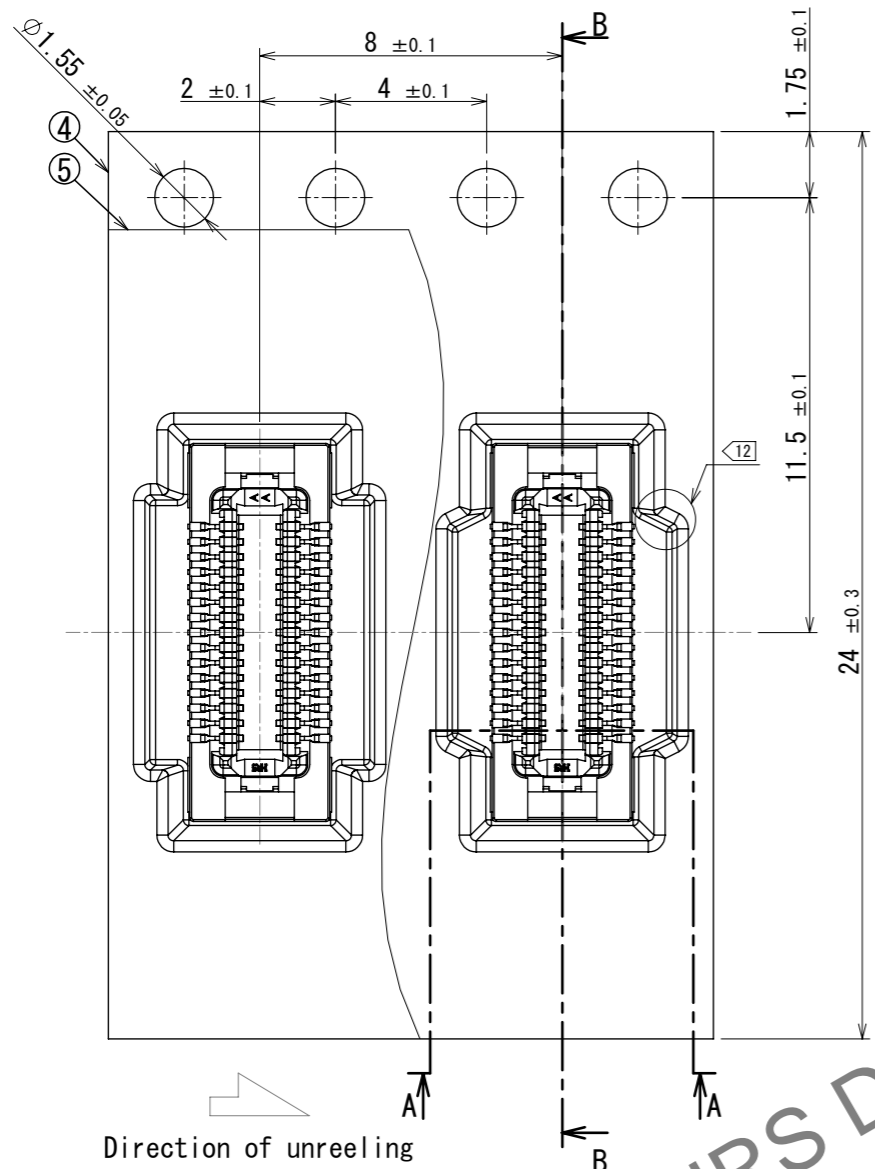

B-B
(5 : 1)

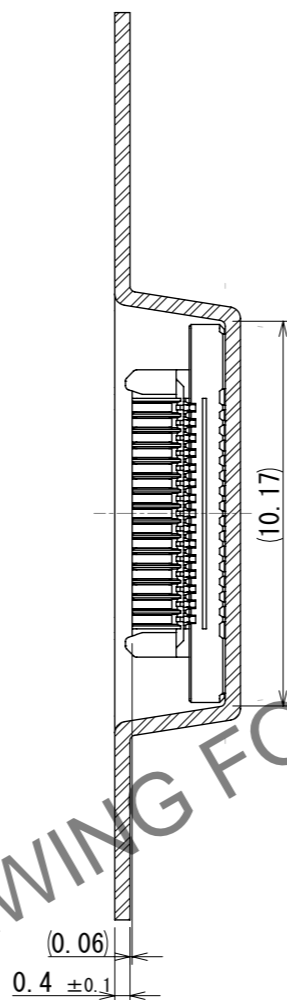

Style and dimension of reel (free)

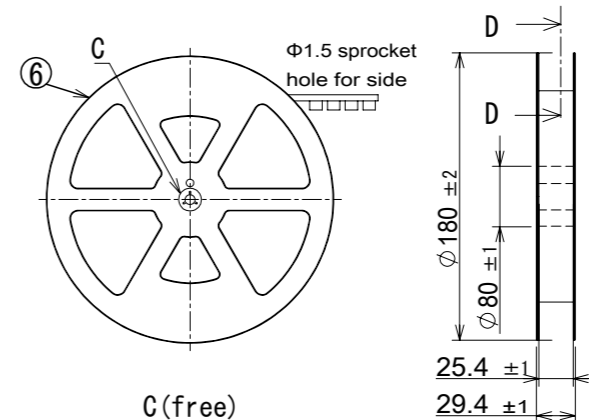

C (free)

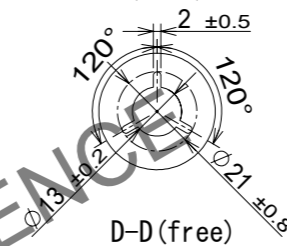

D-D (free)

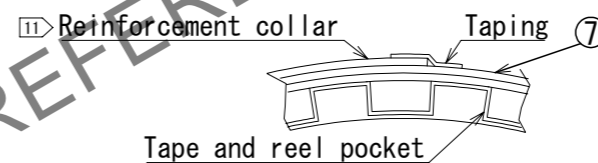
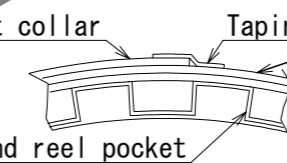

- 9 . 500 connectors per reel.
- 10. Refer to IEC 60286-3 (packaging of components for automatic handling)
- 11. The reinforcing collar is wrapped around the emboss tape and taped down at the end of the collar.
- 12. Some of the pockets may have a different shape.

Direction of unreeling

A-A
(5 : 1)

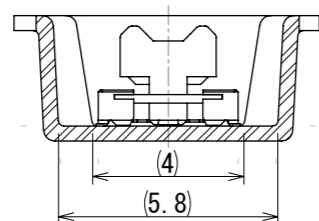

10 Taping (free)

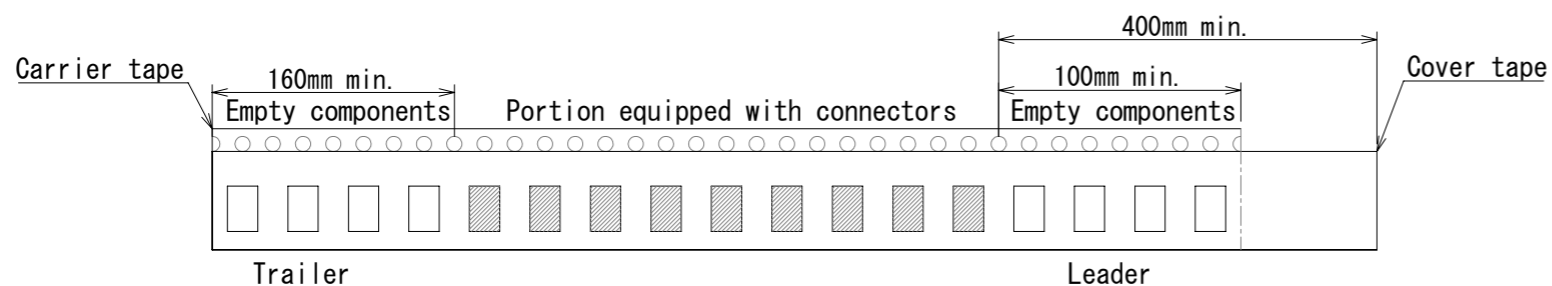

HRS	DRAWING NO.	EDC-394717-53-00	2/3
	PART NO.	BM54F3. 0-30DP-0. 4V (53)	
	CODE NO.	CL0684-4603-0-53	
	NO.		

Oct.1.2024 Copyright 2024 HIROSE ELECTRIC CO., LTD. All Rights Reserved.
In case of consideration for using Automotive equipment / device which demand high reliability, kindly contact our sales window correspondents.

13. Please refer to the product guideline for detail of connector handling.
The position between the connector and PAD

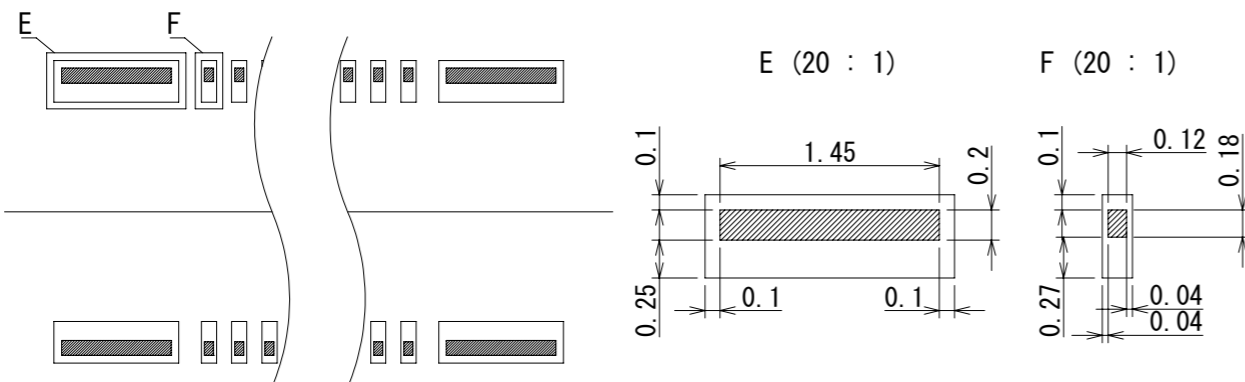

▨ Connector lead on PAD layout
□ PAD layout

Connector area

(1) ▨ is connector area or floating area, if other parts enter this area, it is possible to affect floating performance.

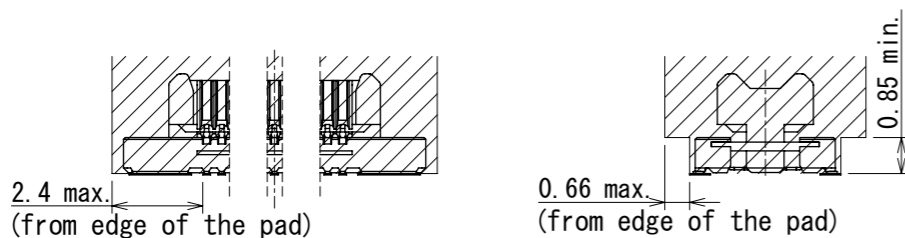

▨ Connector area
■ PAD

Mating method

(1) The alignment dimension is ± 0.4 mm in the X and Y directions.
After the start of mating, follow the alignment and mate perpendicularly to the board without applying an overloading to the connector



Misalignment Allowance in Mated Condition (Floating Range)

(1) Because of floating design, this connector has a ± 0.4 mm board misalignment tolerance in the X and Y directions when mated. However, it is not suitable for absorption when the range of misalignment constantly changes due to vibration, etc. The number of repetitions of floating movable operations is stipulated to be no more than 10 times

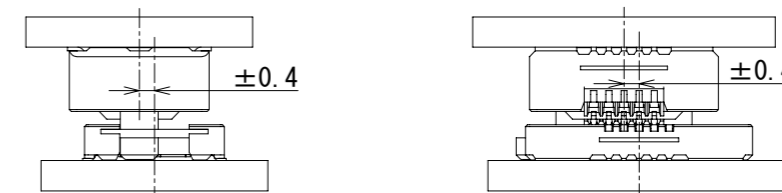

Securing PCBs

(1) This connector can absorb misalignment between PCBs, but not vibration. If you support PCBs only with the connectors without taking any fixing measures, the load on the connectors will be excessive and may cause broken or contact failure. Be sure to secure PCBs except for the connectors as shown below to prevent the board from moving. This connector connects the board to the board. When using mounting to FPC, fasten the board and FPC to the case separately



Fixing PCBs with a spacer or case

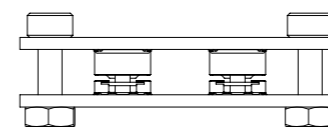

Do not use the product without fixing PCBs together.

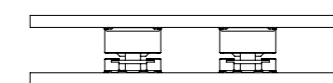

Un-mating method

(1) Un-mate the connectors parallel to each other.

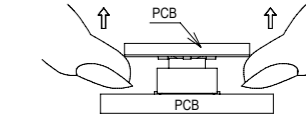
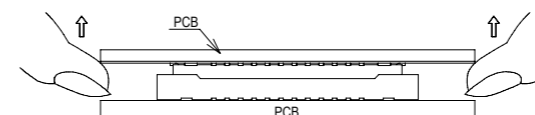

(2) When un-mating the connector, pull it out in parallel. If it is un-mated in an inclined position, connector may deform.

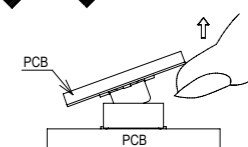
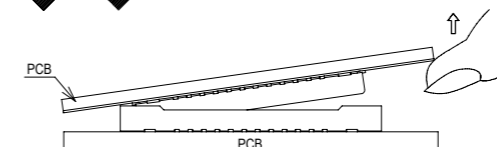

HRS	DRAWING NO.	EDC-394717-53-00	3/3
	PART NO.	BM54F3. 0-30DP-0. 4V (53)	
	CODE NO.	CL0684-4603-0-53	
	NO.		