

1mm Pitch, Board to Wire Lock Connector

DF50 Series

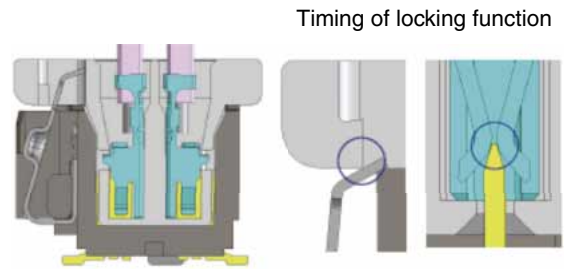

It provides clear tactile click and secure mating



Simultaneous timing of locking function and contact mating provides a clearer tactile click.

Fig.1

■ Features

1. It provides clear tactile click and secure mating

Locking function and contact mating occur simultaneously, for a clearer tactile click. (Fig.1)

2. Robust structure resistant to wrenching forces

Thick and robust housing wall provides higher strength against cracking. Insertion depth for mating housings protects against wrenching. (Fig.2)

3. Robust and reliable lance structure

High lance strength by mating with crimp contact on the surface. (Fig.3)

4. Ensured adsorption area eliminates the need for adsorption cap.

Adequate adsorption area is ensured despite the small size, allowing for automatic mounting without adsorption cap.

(*Specifications for adsorption cap may be provided according to your requirements)

5. Insulation outer diameter $\phi 0.9\text{mm}$, compatible with AWG#28

Despite 1 mm Pitch, it is compatible with $\phi 0.9\text{mm}$, UL1061-28 AWG Cable ($\phi 0.127 \times 7$)

Robust structure resistant to wrenching forces

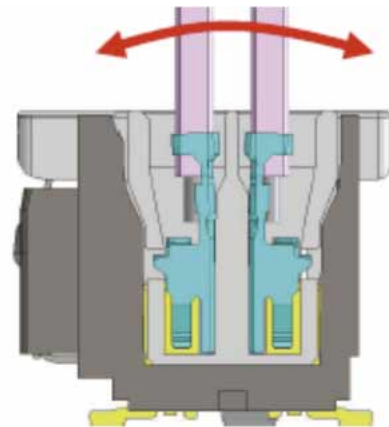

Insertion depth for mating protects against wrenching. Thick and robust outer wall provides higher strength and prevents cracking.

Fig.2

Robust and reliable lance structure

The lance mates with the crimp contact on the surface.

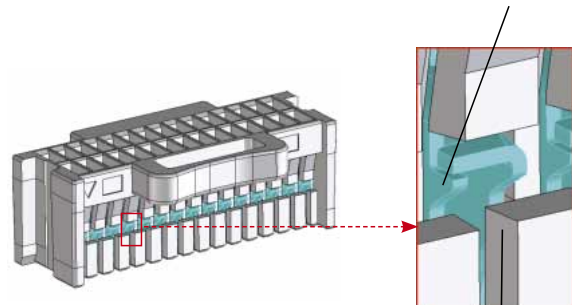

It is possible to visually inspect the assembled lance.

Fig.3

Product Specifications

Ratings	Current Rating	1A (Note 1)	Operating Temperature Range Operating Humidity Range	-35 to +85°C (Note 2) 20 to 80% (Note 3)
	Voltage Rating	AC/DC 100V	Storage Temperature Range Storage Humidity Range	-10 to +60°C (Note 4) 40 to 70% (Note 4)

Items	Specifications	Conditions
1. Insulation resistance	500MΩ min.	100V DC
2. Withstand voltage	No flashover or breakdown	300V AC/1min.
3. Contact resistance	30mΩ max.	20mV max., at 1mA.
4. Vibration	No electrical discontinuity of 1μs or longer	Frequency 10-55Hz, single amplitude of 0.75mm 3 directions, 10 cycles in each direction.
5. Shock	No electrical discontinuity of 1μs or longer	Acceleration : 490m/s ² for 11ms, half sine wave in 3 directions, 3 times for each direction
6. Humidity	Contact resistance : 50mΩ max. Insulation resistance : 100MΩ min.	Temperature : 40±2°C ; humidity : 90 to 95%, left for 96 hours
7. Temperature cycles	Contact resistance : 50mΩ max. Insulation resistance : 500MΩ min.	(-55°C : 30 min. → 5 to 35°C : 2 to 3 min. → 85°C : 30 min. → 5 to 35°C : 2 to 3 min.) 5 cycles
8. Durability	Contact resistance : 50mΩ max.	30 times (Number of insertion and withdrawal)
9. Resistance to soldering heat	No deformation of components affecting performance.	Reflow : according to the recommended temperature profile Hand soldering : 350°C for 3 to 4 sec.

Note 1 : This is the maximum current rating while all pins are powered or used as all power lines. When isolating power lines into multiple circuits, current ratings may go above the stated current ratings. Please consult Hirose for specific details before doing this.

Note 2 : Includes the temperature rise of power lines.

Note 3 : The connector should be completely dry. (no condensation present)

Note 4 : The term "storage" refers to the long-term storage condition of unused products before PCB mounting. The operating temperature and humidity ranges are applied while in a non-energized state, while in transport or after PCB mounting.

Materials / Finish

Product	Part	Materials	Color / Finish	UL Regulation
Pin header (on the board side)	Insulator	LCP	Black Beige	UL94V-0
	Contact	Brass	Gold plating	—
	Metal fitting	Brass (Note 1)	Tin Plating	—
	Locking metal fitting (DF50)	Stainless steel	—	—
Crimp socket	Insulator	PBT	Black (DF50A)	UL94V-0
			White (DF50S)	
Crimp contact	Contact	Phosphor Bronze	Gold plating	—

Note 1 : Phosphor bronze is applied a material for only to the single-row straight pin header.

Product Number Structure

Refer to the chart below when determining the product specifications from the product number.

Please select from the product numbers listed in this catalog when placing orders.

Connector

DF 50 — ***** **DP** — **1 V (**)**

① ② ③ ④ ⑤ ⑥ ⑦ ⑧

Crimp contact

DF 50 — **2830 SCF A**

① ② ③ ④ ⑤ ⑥ ⑦ ⑧ ⑨ ⑩ ⑪

① Series Name : DF	⑧ Specifications 51 : SMT, color : black Embossed packaging 52 : SMT, color : black Embossed packaging, with adsorption cap 61 : SMT, color : beige Embossed packaging 62 : SMT, color : beige Embossed packaging, with adsorption cap
② Series No. : 50	⑨ Applicable wire size 26 : 26 AWG 2830 : 28, 30 AWG 3032 : 30, 32 AWG
③ Form Type : Blank : Double-row pin header S : Double-row crimp socket A : Single-row	⑩ Packaging style SCF : Socket contact reel
④ Number of contacts : 20, 30, 40, 50 (Double-row) : 2 to 16 (Single-row)	⑪ Plating specifications A : Gold plating
⑤ Connector type DP : Double-row pin header DS : Double-row crimp socket P : Single-row pin header S : Single-row crimp socket	
⑥ Contact Pitch : 1mm	
⑦ Mounting style / Wiring type V : SMT Straight Type H : SMT Right Angle Type C : Crimp socket	

Double-row straight pin header

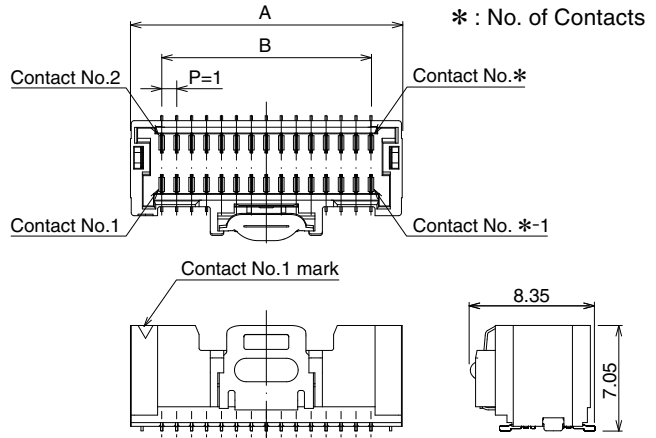
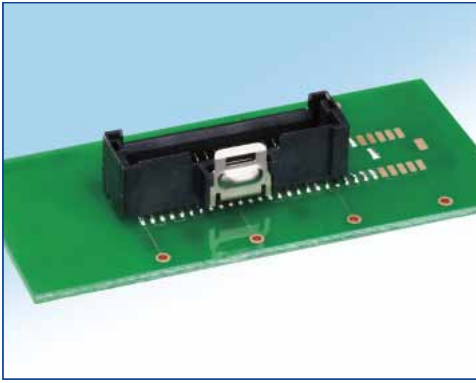

Recommended PCB Dimensions

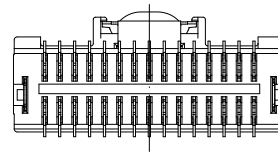
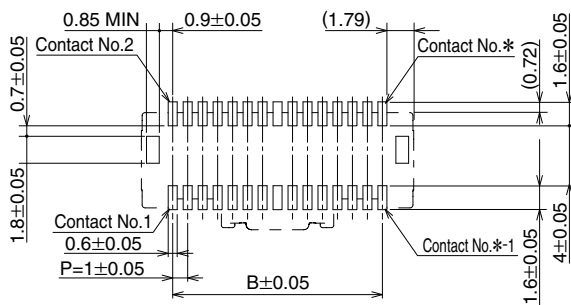

[Specification number]**

- (51) color : black, Embossed packaging
- (52) color : black, Embossed packaging, with adsorption cap
- (61) color : beige, Embossed packaging
- (62) color : beige, Embossed packaging, with adsorption cap

Unit : mm

Part No.	HRS No.	No. of Contacts	A	B	C	D	E	F	G
DF50-20DP-1V (**)	665-0019-3 (**)	20	13.18	9	14.2	28.4	32	38.4	32.4
DF50-30DP-1V (**)	665-0001-8 (**)	30	18.18	14					
DF50-40DP-1V (**)	665-0005-9 (**)	40	23.18	19	20.2	40.4	44	50.4	44.4
DF50-50DP-1V (**)	665-0011-1 (**)	50	28.18	24					

Note : Please place orders for embossed packaged products by the multiple of the number of reels. (1,000 pcs/reel)

Emboss tape dimensions (JIS C 0806 compliant)

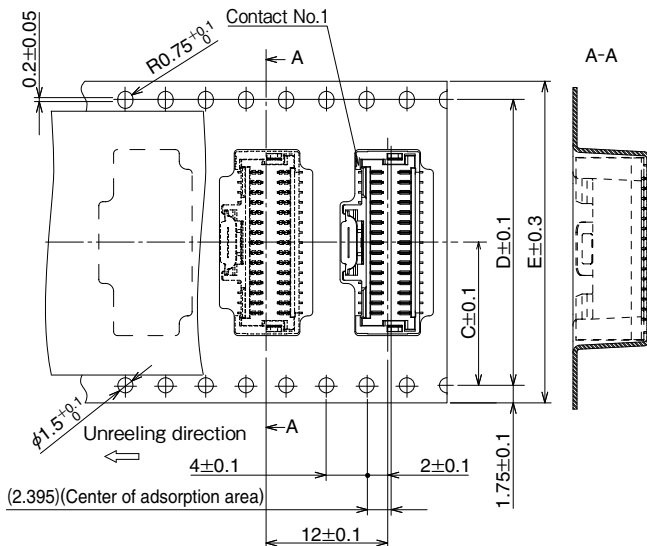

Reel Condition Dimensions

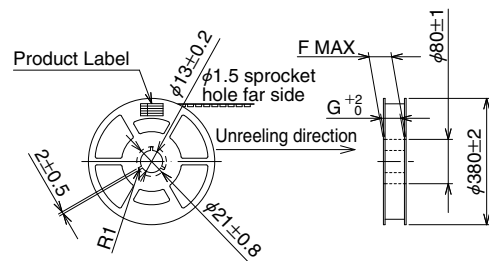

Double-row right angle pin header

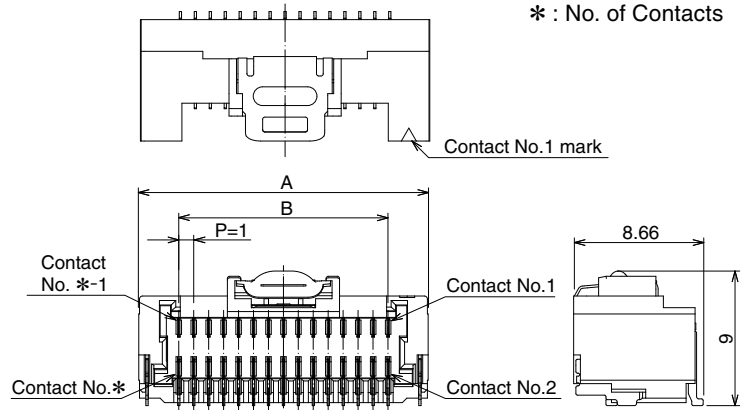
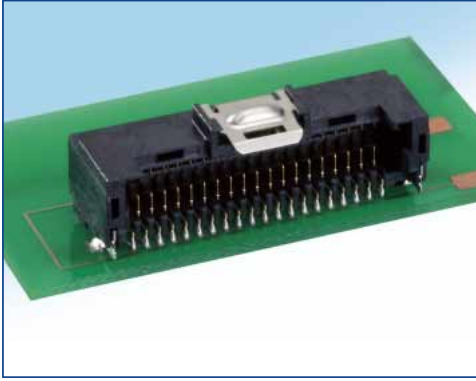

Recommended PCB Dimensions

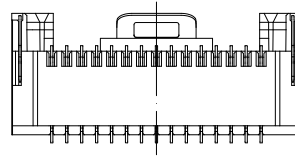
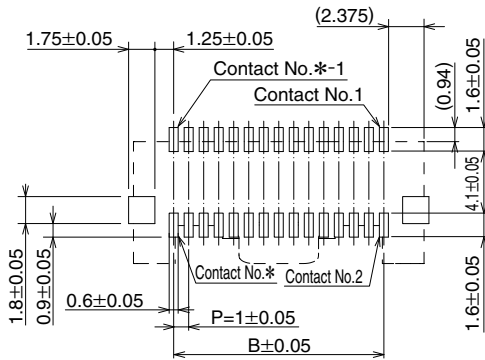

[Specification number]**
 (51) color : black, Embossed packaging
 (61) color : beige, Embossed packaging

Unit : mm

Part No.	HRS No.	No. of Contacts	A	B	C	D	E	F	G
DF50-20DP-1H(**)	665-0016-5 **	20	14.35	9	14.2	28.4	32	38.4	32.4
DF50-30DP-1H(**)	665-0015-2 **	30	19.35	14	20.2	40.4	44	50.4	44.4
DF50-40DP-1H(**)	665-0014-0 **	40	24.35	19					
DF50-50DP-1H(**)	665-0013-7 **	50	29.35	24					

Note : Please place orders for embossed packaged products by the multiple of the number of reels. (600 pcs/reel)

Emboss tape dimensions (JIS C 0806 compliant)

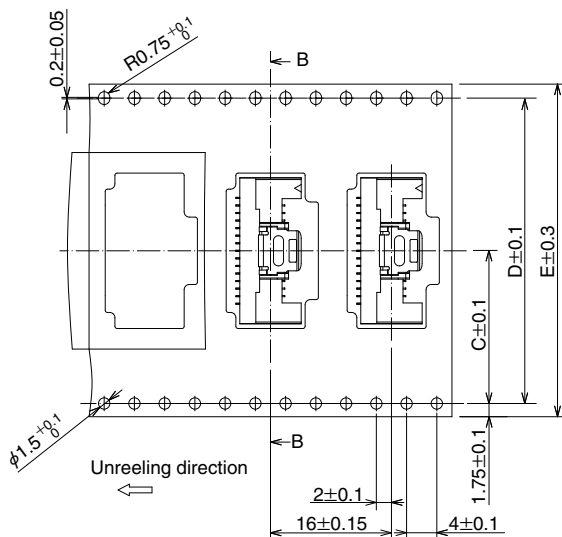

Reel Condition Dimensions

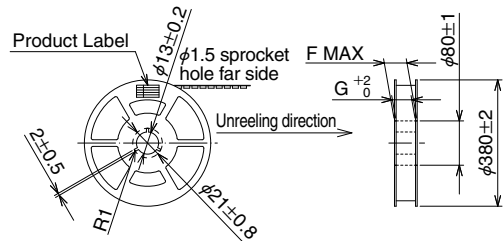

Single-row straight pin header

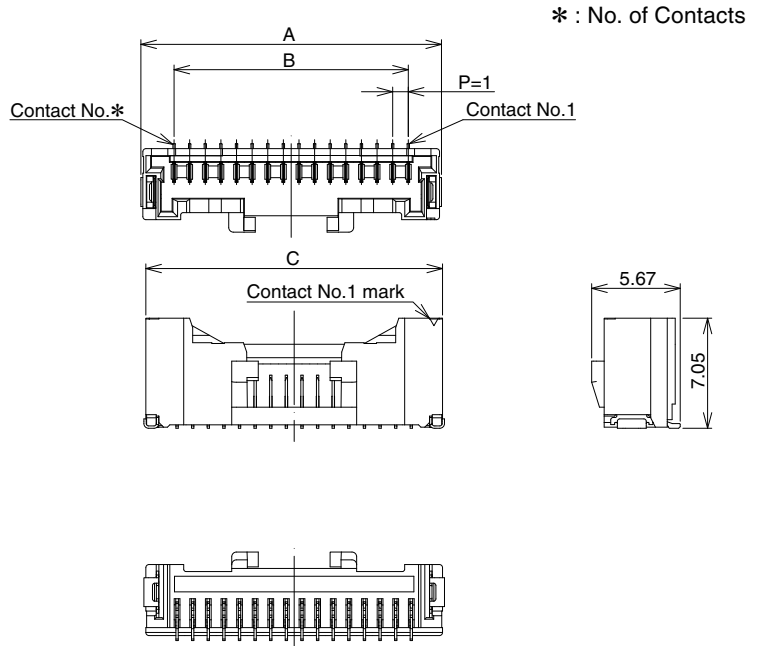
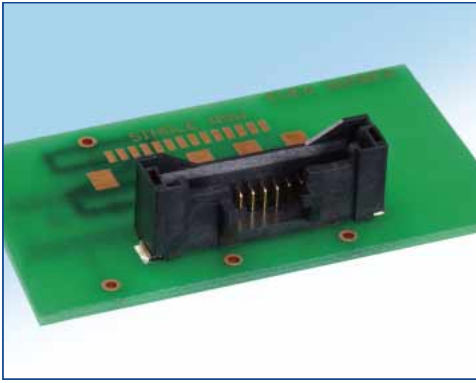

Recommended PCB Dimensions

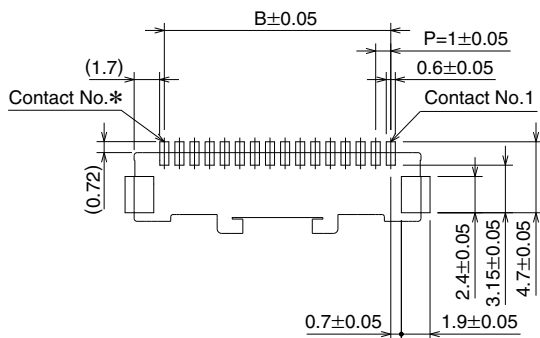

[Specification number]**
(51) color : black, Embossed packaging

Unit : mm

Part No.	HRS No.	No. of Contacts	A	B	C
DF50A-2P-1V (**)	665-1001-3 **	2	5.25	1	5
DF50A-3P-1V (**)	665-1004-1 **	3	6.25	2	6
DF50A-4P-1V (**)	665-1006-7 **	4	7.25	3	7
DF50A-5P-1V (**)	665-1008-2 **	5	8.25	4	8
DF50A-6P-1V (**)	665-1010-4 **	6	9.25	5	9
DF50A-7P-1V (**)	665-1012-0 **	7	10.25	6	10
DF50A-8P-1V (**)	665-1014-5 **	8	11.25	7	11
DF50A-9P-1V (**)	665-1016-0 **	9	12.25	8	12
DF50A-10P-1V (**)	665-1017-3 **	10	13.25	9	13
DF50A-11P-1V (**)	665-1019-9 **	11	14.25	10	14
DF50A-12P-1V (**)	665-1021-0 **	12	15.25	11	15
DF50A-13P-1V (**)	665-1023-6 **	13	16.25	12	16
DF50A-14P-1V (**)	665-1025-1 **	14	17.25	13	17
DF50A-15P-1V (**)	665-1027-7 **	15	18.25	14	18
DF50A-16P-1V (**)	665-1029-2 **	16	19.25	15	19

Note : Please place orders for embossed packaged products by the multiple of the number of reels. (1,000 pcs/reel)

◆ Emboss tape dimensions (JIS C 0806 compliant)

● DF50A-2P-1V to DF50A-8P-1V (Number of contacts : 2 to 8)

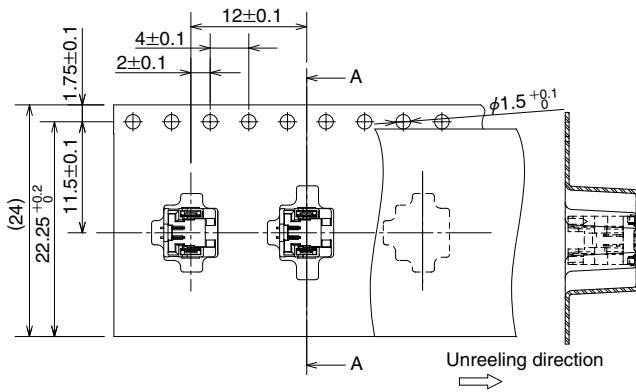

◆ Reel Condition Dimensions

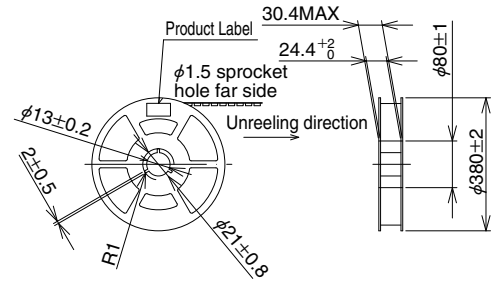

◆ Emboss tape dimensions (JIS C 0806 compliant)

● DF50A-9P-1V to DF50A-16P-1V (Number of contacts : 9 to 16)

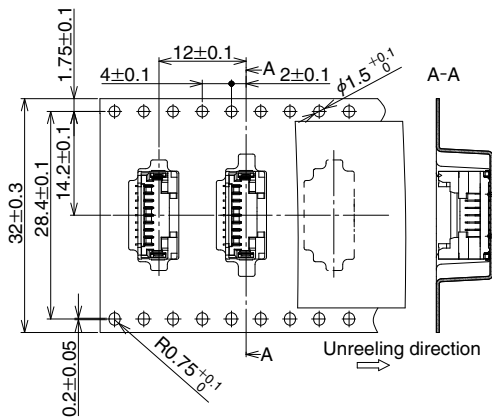

◆ Reel Condition Dimensions

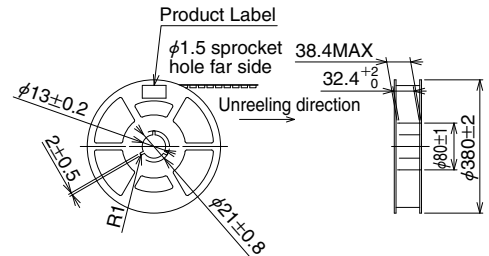

Single-row right angle pin header

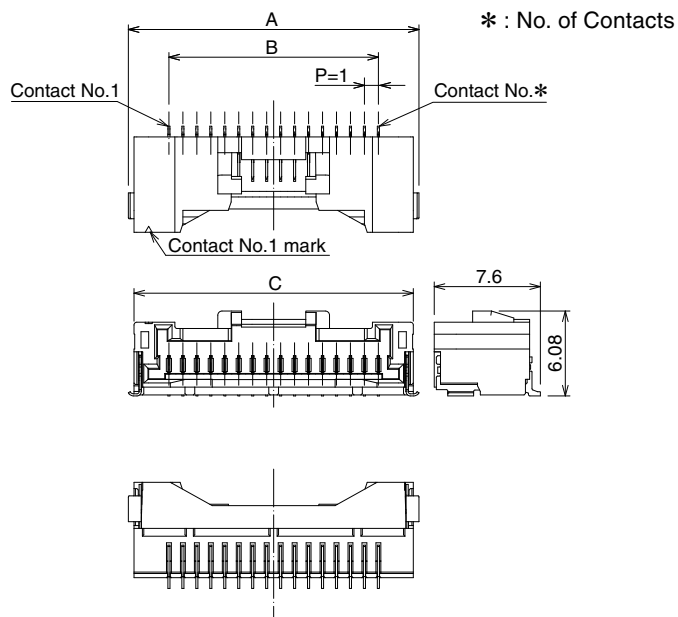
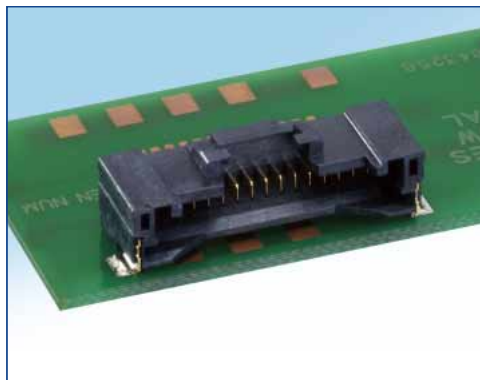

Recommended PCB Dimensions

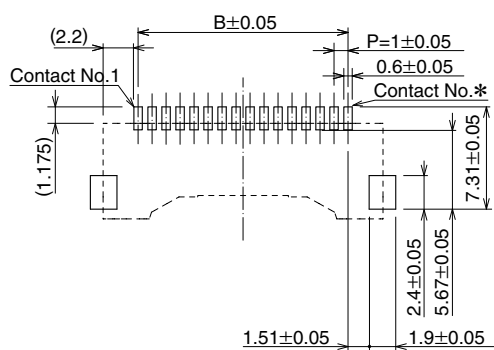

[Specification number]**
(51) color : black, Embossed packaging

Unit : mm

Part No.	HRS No.	No. of Contacts	A	B	C
DF50A-2P-1H (**)	665-1031-4 **	2	6.81	1	6
DF50A-3P-1H (**)	665-1032-7 **	3	7.81	2	7
DF50A-4P-1H (**)	665-1033-0 **	4	8.81	3	8
DF50A-5P-1H (**)	665-1034-2 **	5	9.81	4	9
DF50A-6P-1H (**)	665-1035-5 **	6	10.81	5	10
DF50A-8P-1H (**)	665-1037-0 **	8	12.81	7	12
DF50A-10P-1H (**)	665-1039-6 **	10	14.81	9	14
DF50A-12P-1H (**)	665-1041-8 **	12	16.81	11	16
DF50A-16P-1H (**)	665-1045-9 **	16	20.81	15	20

Note : Please place orders for embossed packaged products by the multiple of the number of reels. (1,000 pcs/reel)

◆ Emboss tape dimensions (JIS C 0806 compliant)

● DF50A-2P-1H to DF50A-6P-1H (Number of contacts : 2 to 6)

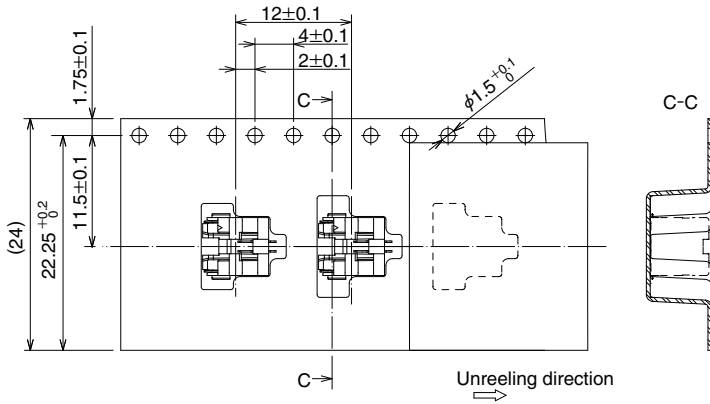

◆ Reel Condition Dimensions

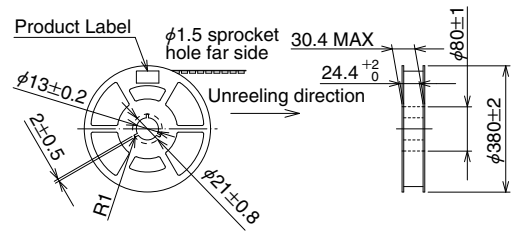

◆ Emboss tape dimensions (JIS C 0806 compliant)

● DF50A-8P-1H to DF50A-16P-1H (Number of contacts : 8 to 16)

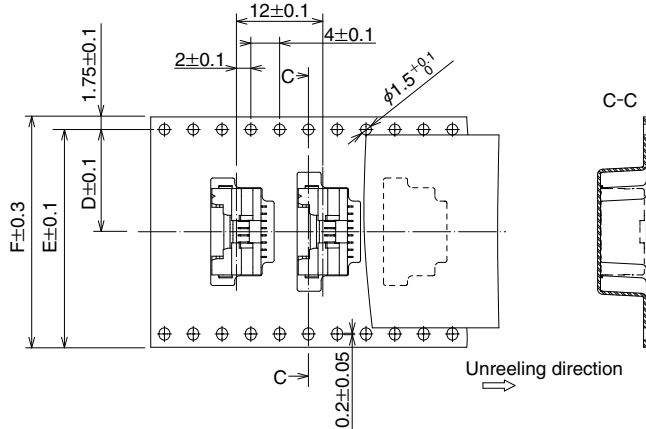

◆ Reel Condition Dimensions

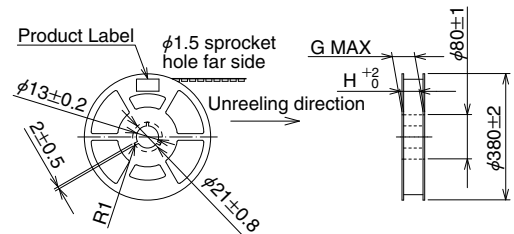

Unit : mm

Part No.	HRS No.	No. of Contacts	D	E	F	G	H
DF50A-8P-1H (**)	665-1037-0 (**)	8	14.2	28.4	32	38.4	32.4
DF50A-10P-1H (**)	665-1039-6 (**)	10					
DF50A-12P-1H (**)	665-1041-8 (**)	12					
DF50A-16P-1H (**)	665-1045-9 (**)	16	20.2	40.4	44	50.4	44.4

Note : Please place orders for embossed packaged products by the multiple of the number of reels. (1,000 pcs/reel)

Double-row crimp socket

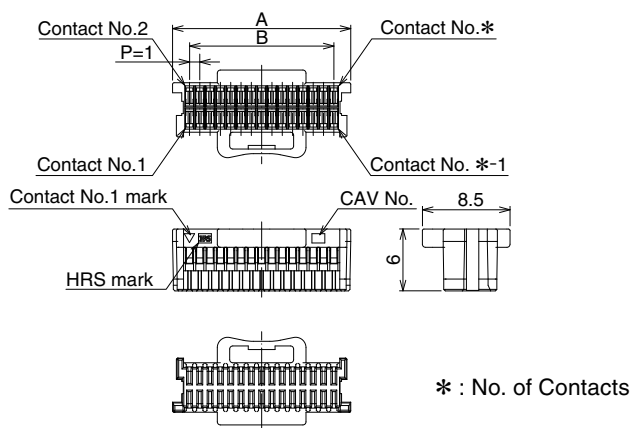

* : No. of Contacts

Unit : mm

Part No.	HRS No.	No. of Contacts	A	B
DF50S-20DS-1C	665-0020-2	20	12.28	9
DF50S-30DS-1C	665-0021-5	30	17.28	14
DF50S-40DS-1C	665-0022-8	40	22.28	19
DF50S-50DS-1C	665-0012-4	50	27.28	24

Note : Sold in 100 pcs/pack.

Single-row crimp socket

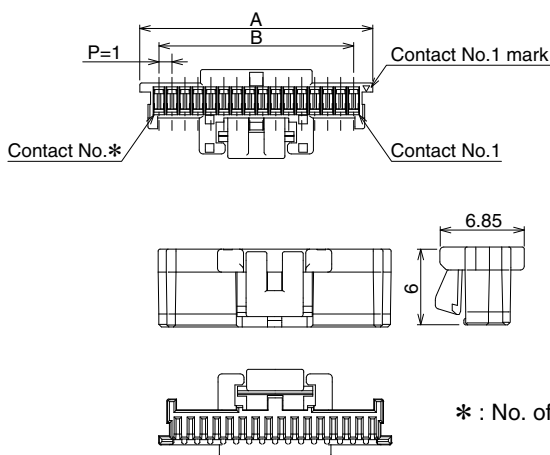

* : No. of Contacts

Unit : mm

Part No.	HRS No.	No. of Contacts	A	B
DF50A-2S-1C	665-1002-6	2	3.95	1
DF50A-3S-1C	665-1005-4	3	4.95	2
DF50A-4S-1C	665-1007-0	4	5.95	3
DF50A-5S-1C	665-1009-5	5	6.95	4
DF50A-6S-1C	665-1011-7	6	7.95	5
DF50A-7S-1C	665-1013-2	7	8.95	6
DF50A-8S-1C	665-1015-8	8	9.95	7
DF50A-9S-1C	665-1100-5	9	10.95	8
DF50A-10S-1C	665-1018-6	10	11.95	9
DF50A-11S-1C	665-1020-8	11	12.95	10
DF50A-12S-1C	665-1022-3	12	13.95	11
DF50A-13S-1C	665-1024-9	13	14.95	12
DF50A-14S-1C	665-1026-4	14	15.95	13
DF50A-15S-1C	665-1028-0	15	16.95	14
DF50A-16S-1C	665-1030-1	16	17.95	15

Note : Sold in 100 pcs/pack.

Feb. 1. 2021 Copyright 2021 HIROSE ELECTRIC CO., LTD. All Rights Reserved.

■Crimp contact

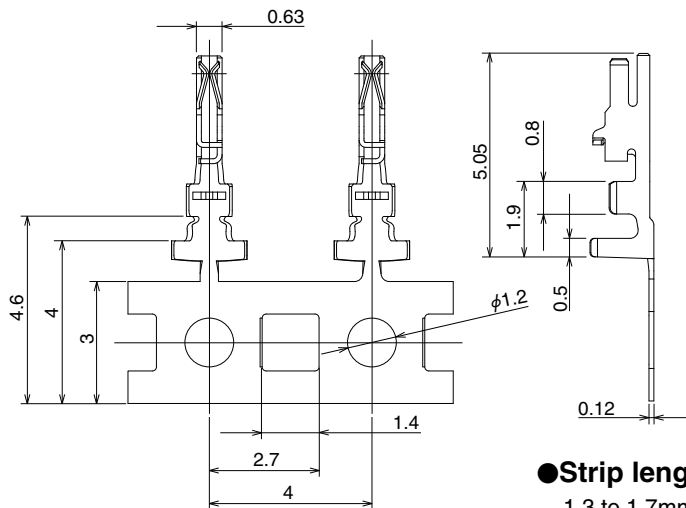

●Strip length
1.3 to 1.7mm

●Reel contact (30,000 pcs/reel)

Part No.	HRS No.	Applicable wire (Tin plated annealed copper wire) (Note 1)				
		UL	Wire size	Stranded wire conductor	Section area	Jacket outer diameter
DF50-26SCFA	665-0023-0	3302	26 AWG	7/0.160mm	0.141mm ²	0.88mm
DF50-2830SCFA	665-0002-0	1061	28 AWG	7/0.127mm	0.089mm ²	0.80 to 0.88mm
			30 AWG	7/0.102mm	0.057mm ²	
DF50K-2830SCFA	665-0017-8	1571	28 AWG	7/0.127mm	0.089mm ²	0.58mm
			30 AWG	7/0.102mm	0.057mm ²	
DF50-3032SCFA	665-0026-0	1571	30 AWG	7/0.102mm	0.057mm ²	0.54 to 0.56mm
			32 AWG	7/0.080mm	0.035mm ²	

Note 1 : When using other than the recommended wire, contact your nearest Hirose sales representative.

Note 2 : The strip length is a reference value. Please make adjustments so finished crimps will meet the specified values. Refer to the crimping quality standards (ETAD-H0616-00) for details.

Note 3 : As this product is sold 30,000 pcs/reel, please place orders by the multiple of the number of reels.

◆Applicable crimping tool

Type	Part No.	HRS No.	Applicable contact	Remarks
Applicator	AP105-DF50-2630S	901-4641-7	DF50-26SCFA	
	AP105-DF50K-2830S	901-4628-9	DF50K-2830SCFA	
	AP105-DF50-3032S	901-4648-0	DF50-3032SCFA	
	DHS799100-BH(-UP)	—	DF50-2830SCFA	Manufactured by Japan Automatic Machine Co., Ltd. (Note 4)
	DHX001800K(-UP)	—	DF50K-2830SCFA	
Press	CM-105C	901-0001-0	—	
Hand crimping tool	HT305/DF50-2830HC (Note 3)	902-4634-8	DF50-2830SCFA	
Contact extraction tool	DF-C-PO(B)	550-0179-2	DF50(K)-***SCFA	

Note 1 : Please do the crimping operations according to the "Crimping quality standard (ETAD-H0616-00)" and "Crimping condition table".

Note 2 : If any trouble has occurred due to tools other than the designated tool, Hirose bears no responsibility for any trouble.

Note 3 : The compatible wire is limited to UL1061, 28 to 30 AWG.

Note 4 : Please contact Japan Automatic Machine Co., Ltd. (hereinafter J.A.M.) through their website regarding crimping issues when using applicators manufactured by J.A.M. URL <http://www.jam-net.co.jp>

◆Mated dimensions

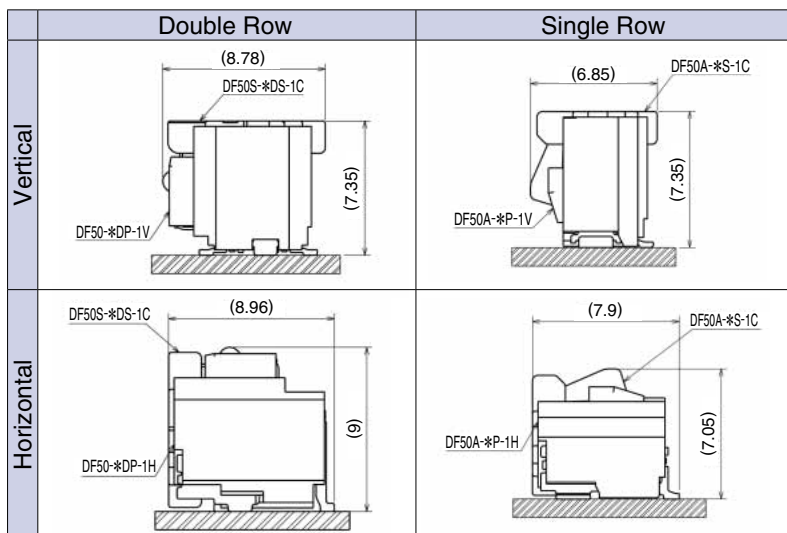

◆ Crimping

■ Items required prior to start crimping

The work-related documents shown below are required before starting the harness connections.
(The ● mark shows the document required.)

When the documents shown below are not available, ask our sales personnel to provide them.

Document Title	Description	Automatic Crimping Machine	Hand Crimping Tool	Remarks
(1) Main unit of crimping machine instruction manual	Explanation of main press machine unit	●	—	When purchasing main press machine unit, it is bundled.
(2) Applicator Spare Parts Identification	Explanation for Applicator installation	●	—	When purchasing Applicator, it is bundled.
(3) Crimp Conditions	Standard values of : Crimp height ; Tensile strength	●	—	
(4) Crimp Quality Standards	Various standards for crimping conditions	●	—	
(5) Operating Instructions for Hand Tool	Inspection items of : Crimp height ; Tensile strength ; and others	—	●	When purchasing Hand Tool, it is bundled.
(6) Harness Procedure Manual DF50 series : ETAD-H0354-00 DF50A series : ETAD-H0437-00	Harness procedure	●	●	Ask our sales personal to provide them.

■ Tools

When crimping work is applied to our contacts, the tool designated by Hirose should be used.

Crimping work by using tools other than as designated must not be done because it may result in contact failure, disconnection of cable, etc.

*The operating instructions manual is available for the crimping machine and the applicator. Be sure to carefully read the operating instructions manual before implementing the work.

■ Applicable electric wires

Check that the electric wire to be used is in the range of application.

If you intend to use an electric wire other than the recommended one, ask our sales personnel.

[Precautions]

- Electric wires that are applicable for crimping connectors shall, principally, be the tin-plated stranded soft-copper wire.
- Crimping of electric wires wherein single wires, polyester yarns, etc., exist and crimping of tin-coated wires should be avoided.
- Avoid crimping two electric wires together.
- The setting values of crimp height (Note 1) may vary between tin-plated and gold-plated terminals even if the same electric wires are used.
- The setting values of crimp height (Note 1) may vary depending on the difference in the core wire configuration even if the computed cross-sectional area is the same.

Note 1 : The crimp height is an important item that determines crimping quality. We execute crimping tests for each electric wire to ensure the optimal value for the crimp height with high precision, thereby ensuring optimal setup values.

◆Precautions

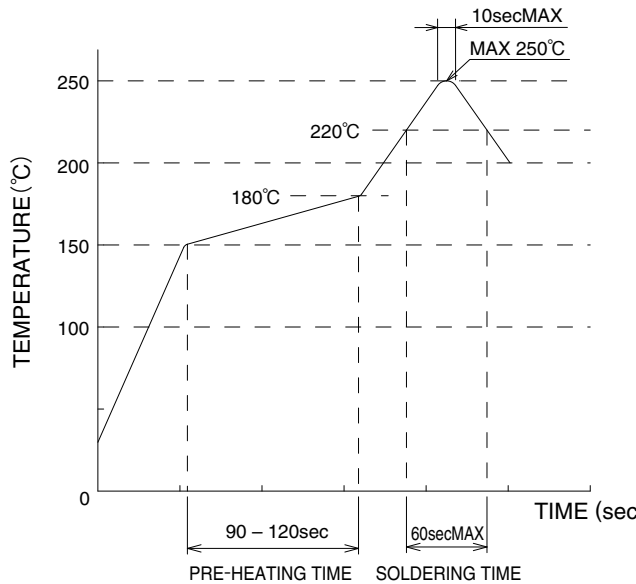
<p>1.Recommended Temperature Profile (Compatible with lead-free soldering)</p>	 <p>[Applicable Conditions]</p> <ol style="list-style-type: none"> 1. Peak temperature : a maximum of 250°C for no more than 10 seconds 2. Heating unit : no less than 220°C for no more than 60 seconds 3. Preheating unit : 150 to 180°C for 90 to 120 seconds 4. Number of times : no more than 2 times <p>* Measurement is conducted at the contact lead part As it may change depending on the conditions such as solder paste types, manufacturers, PCB size, and other soldering materials, please fully check the mounting conditions before use. (Note 1) This temperature profile is a recommended value.</p>
<p>2.Recommended hand soldering conditions</p>	<p>Temperature of soldering iron : 350±10°C, soldering time : 3 to 4 seconds</p>
<p>3.Recommended screen thickness and aperture ratio (Pattern surface ratio)</p>	<p>Thickness : 0.1mm, aperture ratio : 100%</p>
<p>4.Warpage of the Board</p>	<p>A maximum of 0.02mm at the center of connector, as measured from either end of the connector</p>
<p>5.Cleaning Conditions</p>	<p>IPA cleaning is allowed. (Cleaning is not recommended because cleaning may change the push/pull feeling etc. Please contact us when you use other cleaning agents.)</p>
<p>6.Precautions</p>	<ul style="list-style-type: none"> ▪ When inserting crimp-type (solderless) terminals to crimping (solderless) sockets, to maintain reliable performance, please do not insert obliquely. ▪ Please refer to the documents "DF50 Series Cable assembly Procedure ETAD-H0354", "DF50A Series Cable assembly Procedure ETAD-H0437", "Crimp condition" and "DF50#-***SCFA(%%) Crimp quality standards ETAD-H0616-00" for the cable assembly procedures. ▪ Please refrain from pushing/pulling operation when the PCB is not mounted. It may cause breakage, contact deformation, etc. ▪ Please refrain from pushing/pulling operation with wires in your hand. It may cause damage. ▪ During hand soldering, do not apply flux which will cause flux oozing on connector. ▪ This product may have a little difference in its molded color depending on the production lot, but the difference doesn't have any influence on the performance.
<p>7.Handling instructions</p>	<p>Please refer to the following documents in handling this product.</p> <ul style="list-style-type: none"> ▪ Crimp quality standards (ETAD-H0616-00) ▪ Cable assembly Procedure (ETAD-H0354-00, ETAD-H0437-00) ▪ User guide for Wire-to-Board connector



HIROSE ELECTRIC CO.,LTD.

2-6-3,Nakagawa Chuoh,Tsuzuki-Ku,Yokohama-Shi 224-8540,JAPAN
 TEL: +81-45-620-3526 Fax: +81-45-591-3726
<http://www.hirose.com>
<http://www.hirose-connectors.com>