

# 技術指定書 (TECHNICAL-SPECIFICATION)

SIGN	WRITTEN	DESIGNED	CHECKED	APPROVED	RELEASED
	CHOI J.S 18.04.27	CHOI J.S 18.04.27	LIM S.M 18.04.27	LIM S.M 18.04.27	

Document No.	DOC180208-010			SHEET	1/4	
<b>Title</b>  DF51K-SERIES DF51K Operation Manual	NO.	COUNT	DESCRIPTION OF REVISIONS	DESIGNED	CHECKED	DATE
	△	-	structure change	K.I.Y	L.S.M	18.07.11

## 1. Scope

This document specifies the insertion/extraction procedures of DF51K Series.

## 2. Part No.

Part Number	Description
DF51K-*P(DP)-2DS(A)	Header
DF51K-*S(DS)-2C	Socket
DF51K-####SC(F)A	Crimp contact

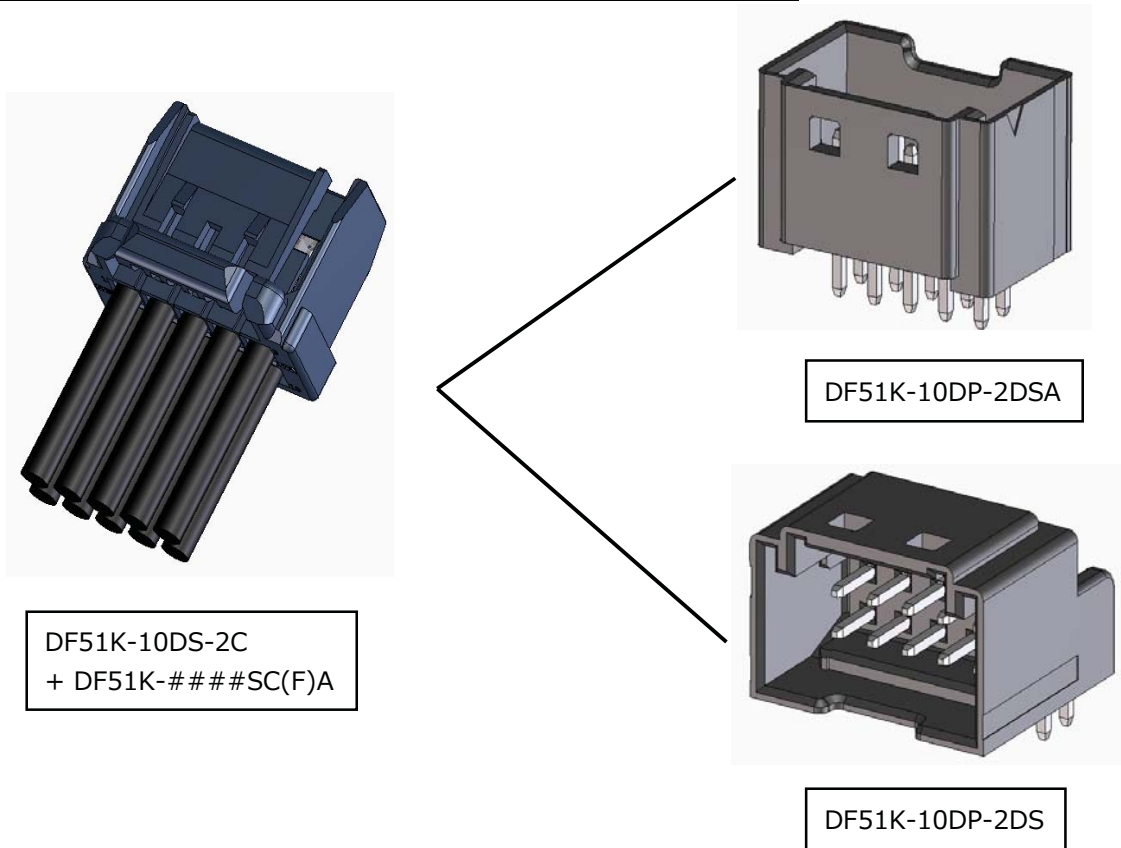

Fig. 1.DF51K

### 3.Operation Procedures

#### 3-1.Insertion

##### 3-1-a.Matching inserting direction

: Match inserting direction of header and socket according to their lock position

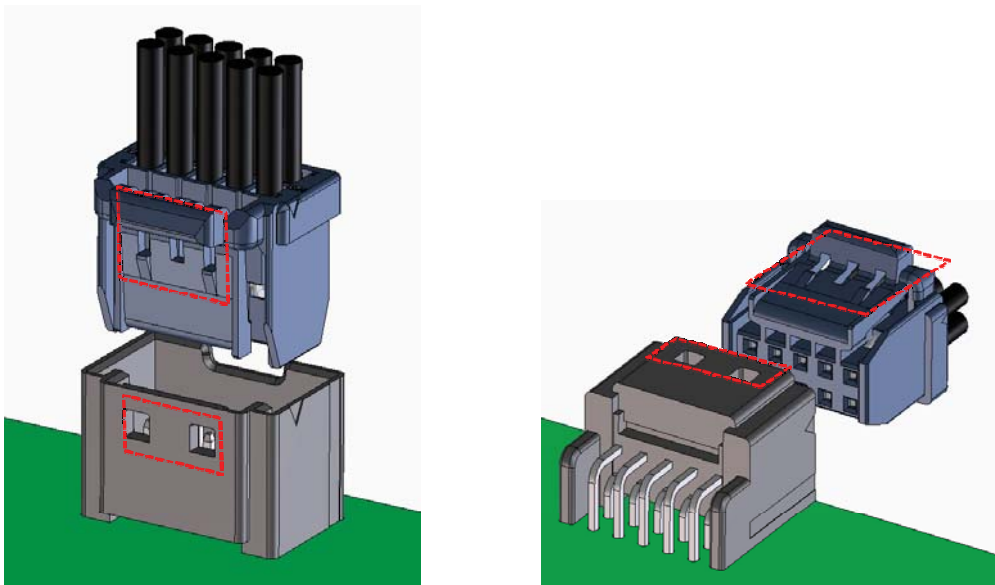

Fig. 2. Matching Insertion

##### 3-1-b.Insertion

: Insert socket until tactil click feel generates,  
keeping the inserting direction and not pressing the lock part.

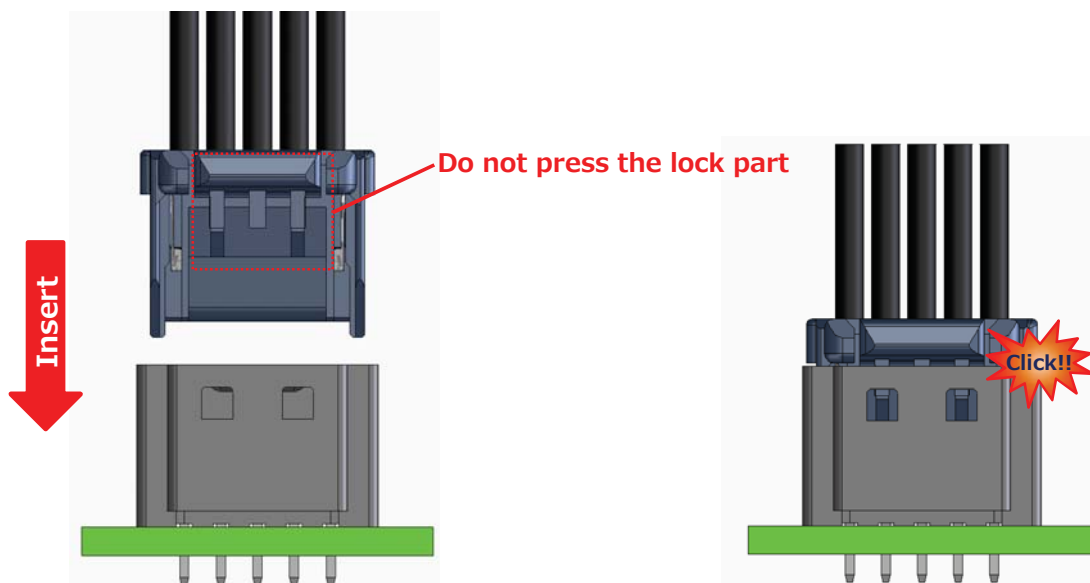

Fig. 3. Insertion

Caution 1 : Do not insert socket with oblique angle as the below Fig. 4.  
Oblique insertion might lead to a defect in product.

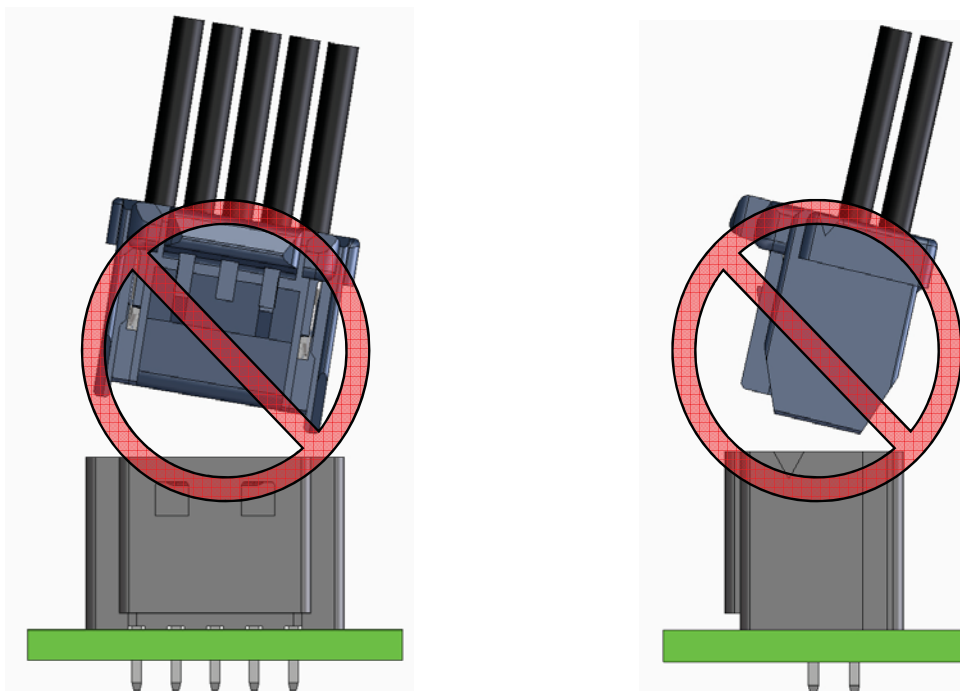

Fig. 4. Prohibited inserting method

### 3-1-c.Mating Check

: Check the mating condition whether the lock of the socket is securely has been caught at the lock of the header.  
(Proceed optical inspection or slightly pull the cable to check.)

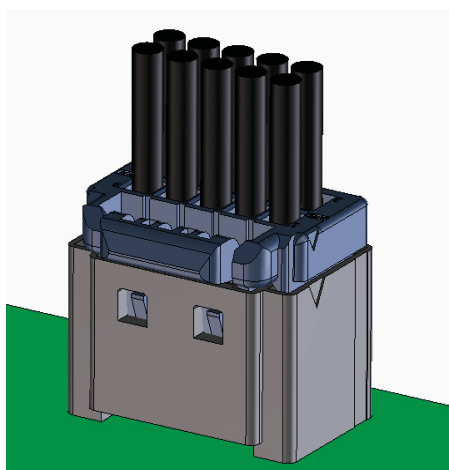

Fig. 5. Mating

### 3-2.Extraction

#### 3-2-a.Cable holding

: Hold securely all of the cables.

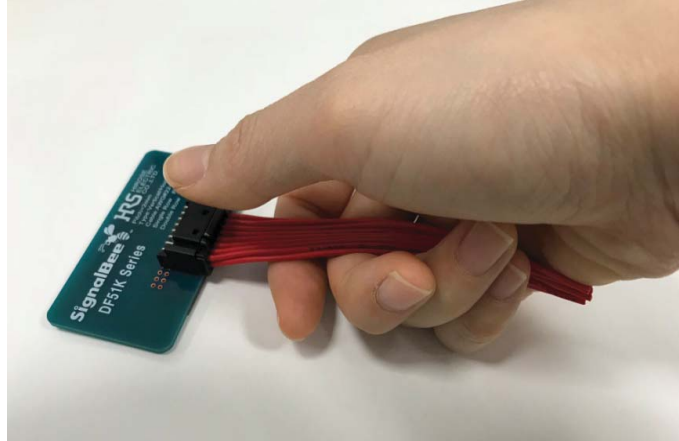

Fig. 6. Cable holding

#### 3-2-b.Unlocking

: Release the locking as pressing the lock button with finger and pull out the cable.

Caution) If the locking is not released, the socket would not be extracted properly from header.

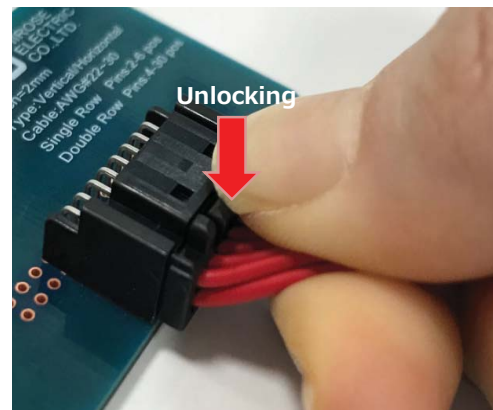
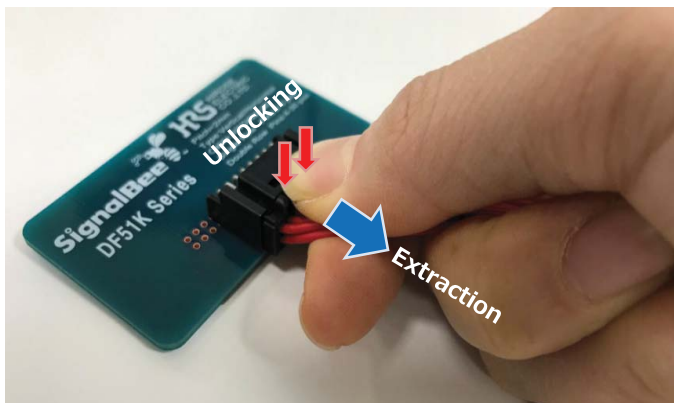

Fig. 7. Unlocking method

## 4.Precaution

- Do not insert or remove the cable while electrifying.
- Excessive stress applied to connector could cause failure and/or deformation. Avoid forcible removal and drop impact.