

1. Scope

This document specifies the steps from crimping the DF62W-series crimped terminals to cables (AWG22 ~ AWG26) to inserting the terminals to crimping sockets.

2. Connectors

■ Crimping cases

DF62W - * EP - 2.2 C

- ① ② ③ ④ ⑤

①	Name: DF62W
②	No. of poles: 2 ~ 9
③	Connector types S : Socket EP: In-line plug
④	Contact pitch: 2.2 mm
⑤	Shape of connection/terminal C: Crimping case

△ ■ Crimped terminals

DF62W - EP 2226 PCF A

- ① ② ③ ④

①	Application EP: In-line
②	Compatible cables 2226: AWG22 ~ 26
③	Shape/packing SCF : Socket terminal, reeled SC : Socket terminal, separate PCF : Plug terminal, reeled PC : Plug terminal, separate
④	Plating A : Gold plating Blank : Tin plating

■ Water proof pin

DF62W - WP

- ①

①	Application WP: Waterproof pin
---	-----------------------------------

	COUNT	DESCRIPTION OF REVISIONS	DESIGNED	CHECKED	DATE
△ 1	2	DIS-H-008764	KT.ISHII	HK.UMEHARA	14.05.19
TITLE			 HIROSE ELECTRIC CO.,LTD. APPROVED KI.AKIYAMA 14.02.15 CHECKED OM.MIYAMOTO 14.02.14 DESIGNED KT.ISHII 14.02.13 WRITTEN KT.ISHII 14.02.13		
DF62W Series Cable Assembly Procedure					
TECHICAL SPECIFICATION					
			ETAD-H0760	△	1 / 8

3. Steps for harnessing

3.1. Cable stripping

Strip cables in accordance with Crimping Quality Standards (ATAD-H0762/0763).
In so doing, make sure there is no scratch on cable cores.

3.2. Crimping

Crimped terminals to cables using an applicator (AP105-DF62W-2226), and check the crimping height and shape in accordance with the Table of crimping conditions and Crimping Quality Standards (ATAD-H0762/0763).

3.3. Insertion to crimping terminal sockets

Hold the cable of a crimped terminal, and insert it to each terminal hole of crimping sockets.
(Insert the terminal in the direction of arrows below.)

*The figures show insertion to DF62W-2EP-2.2C and DF62W-2S-2.2C.

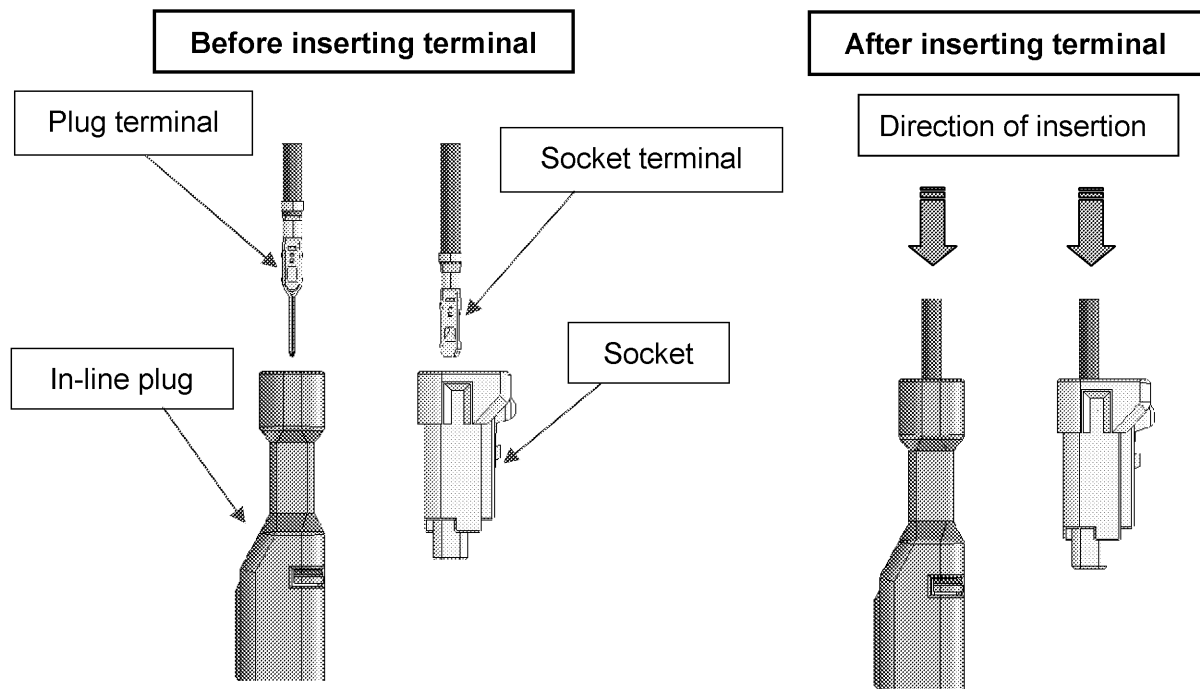

- For insertion, place the crimped terminal and crimping socket lock in the following direction:

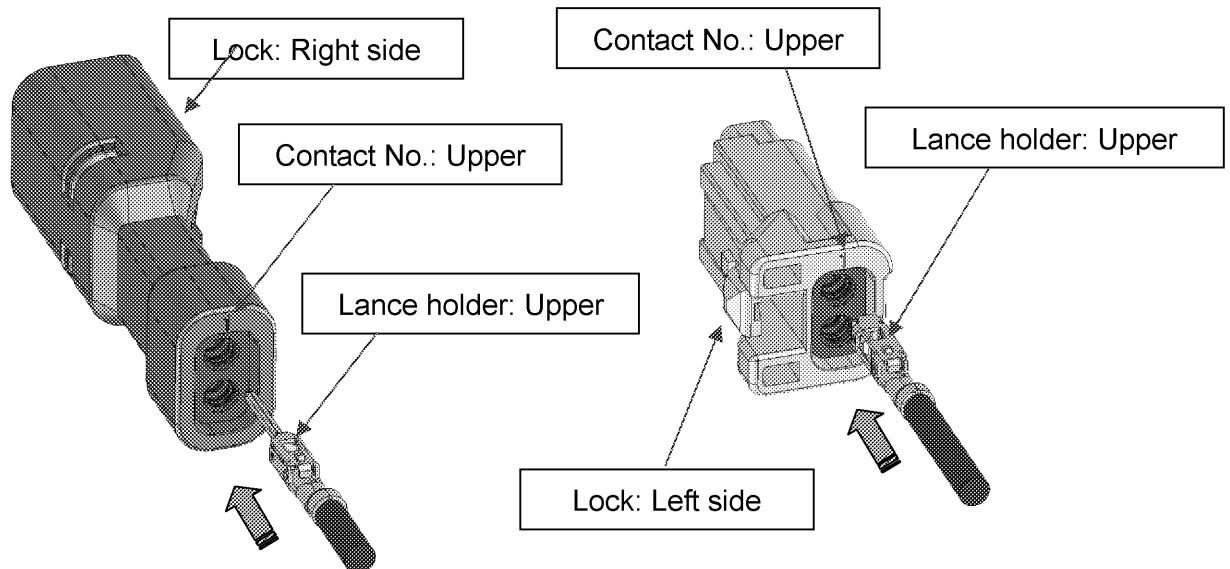

- Insert the crimped terminal to pass through the hole of wire seal.

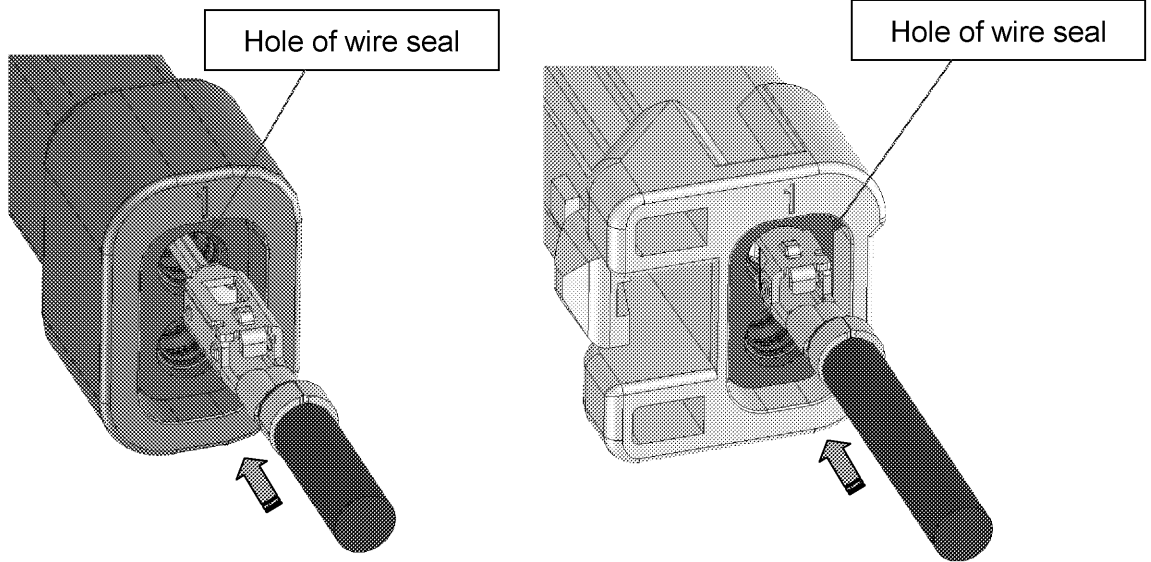

- To maintain performance reliability, do not tilt crimped terminals for insertion.

Horizontal insertion ○

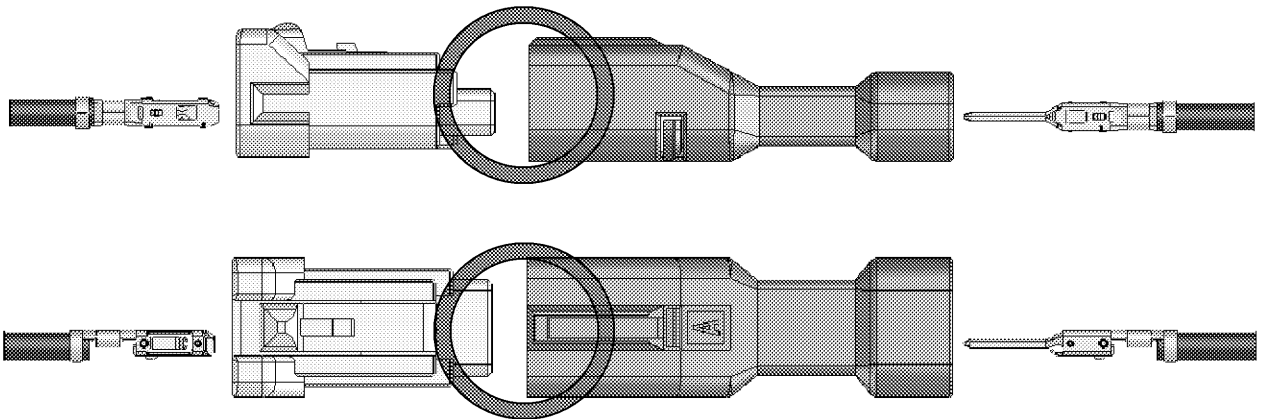

Tilted insertion ×

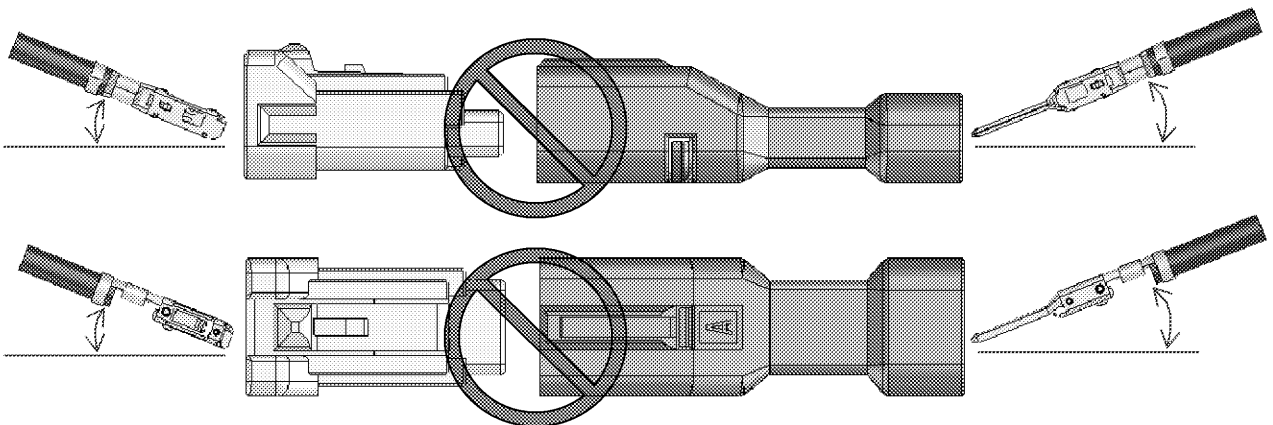

- Check that the lance of a crimping socket has been caught at the lance holder of a crimped terminal.
(Slightly pull the terminal to check.)
*To remove the crimped terminal halfway through insertion, pull the cable while pressing wire seal to prevent coming off.

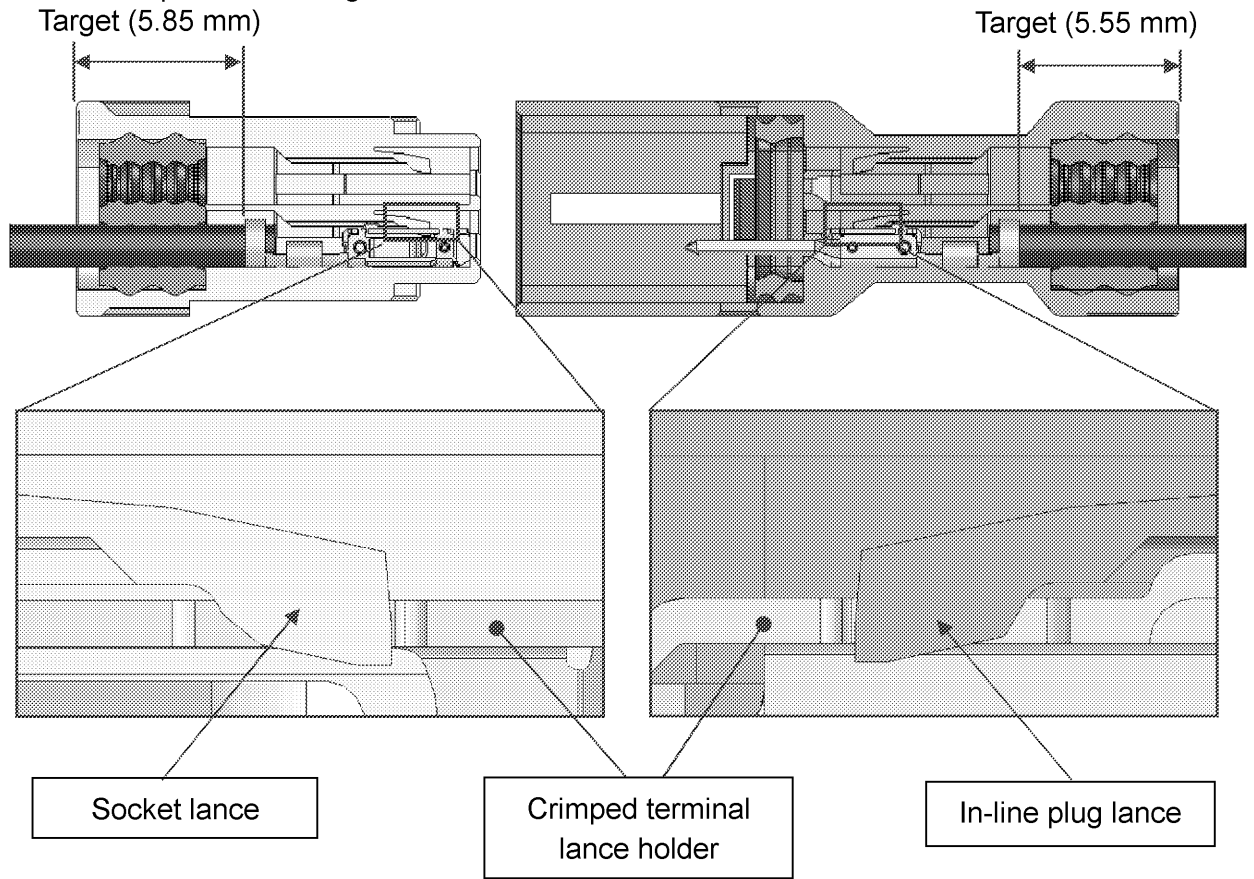

3.4. Insertion of waterproof pin

If you use waterproof pins, insert them to each holes with designated terminal numbers.
(Insertion direction is shown by arrows in the figure below.)

*The figures show insertion to DF62W-2EP-2.2C and DF62W-2S-2.2C.

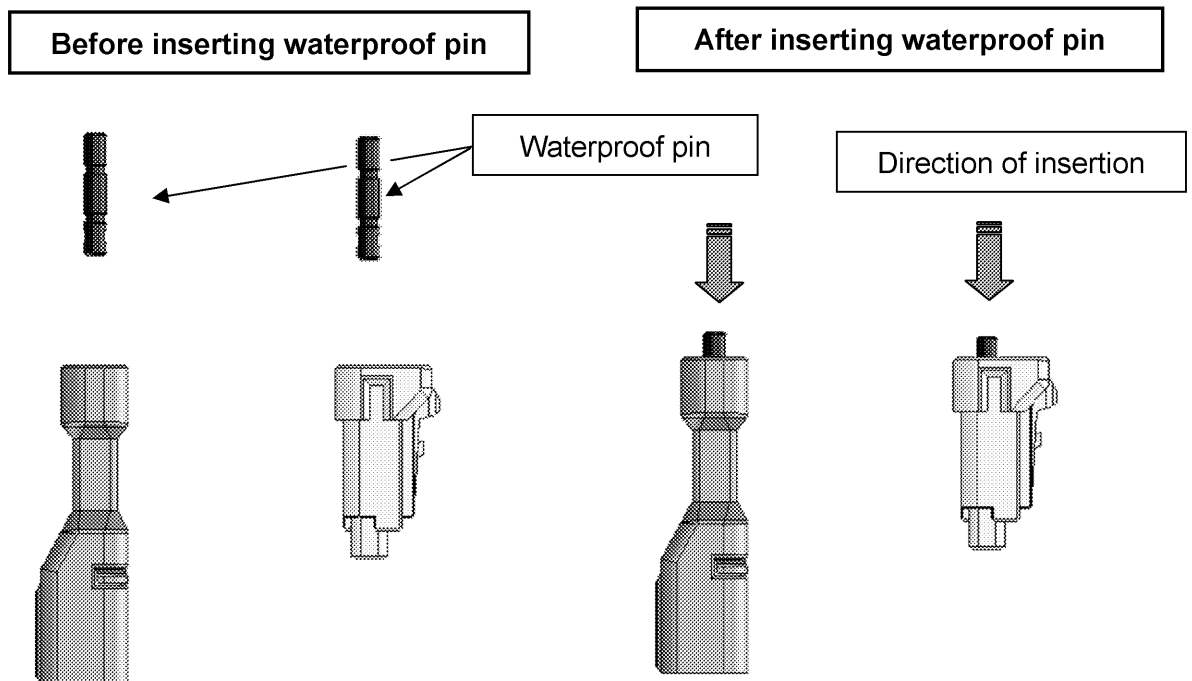

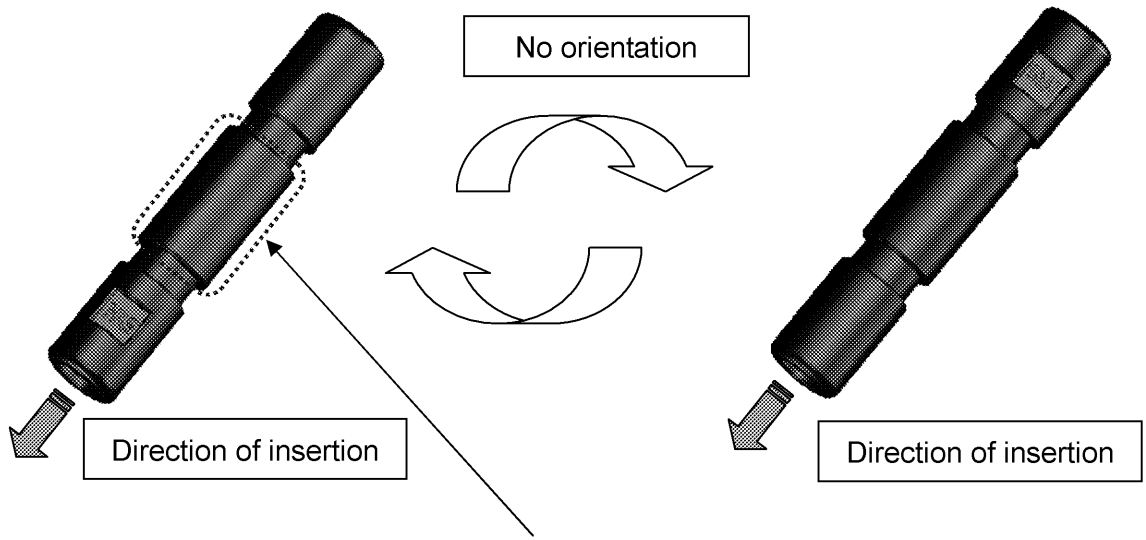

This surface is waterproof surface, so take care not to damage the surface.

- To maintain performance reliability, do not tilt waterproof pin for insertion.

Horizontal insertion ○

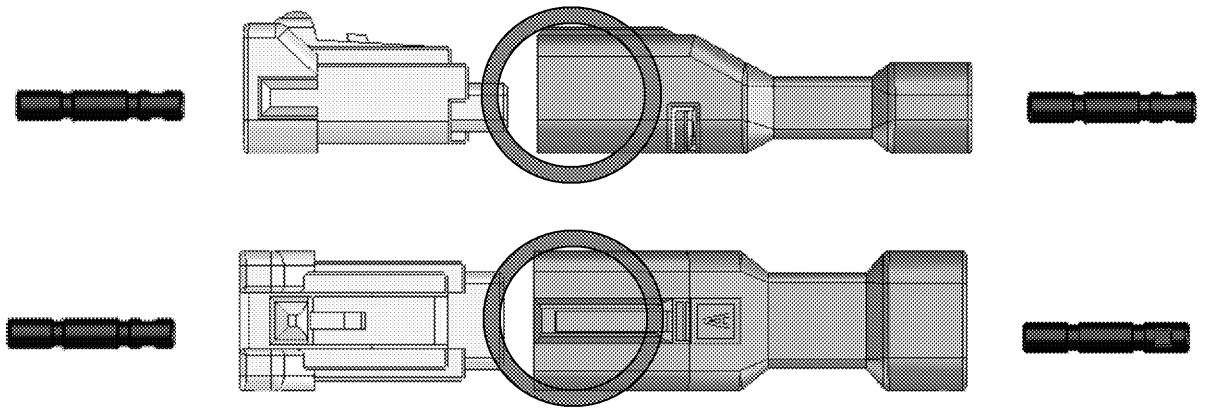

Tilted insertion ×

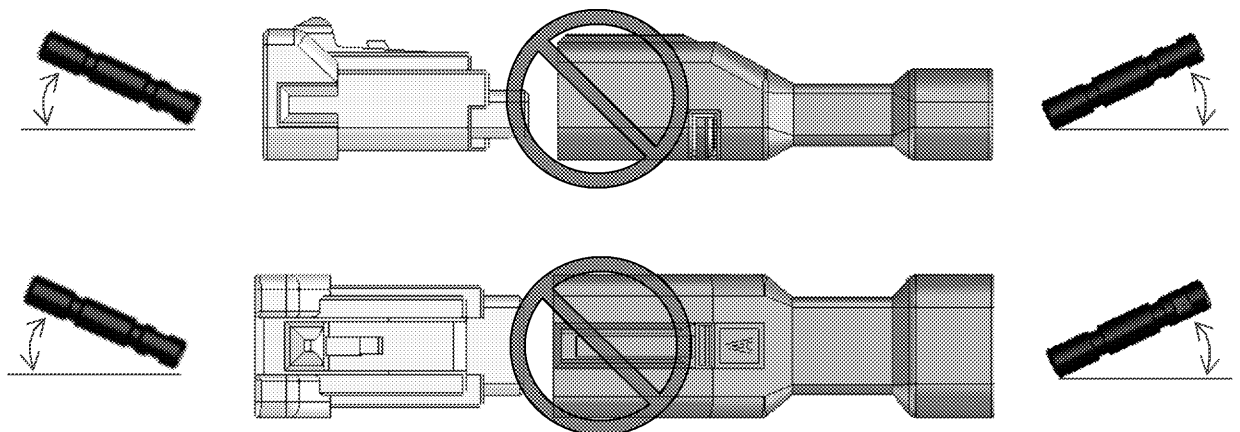

- Insert a waterproof pin until it touches crimping socket.
 *Insertion more than the target dimension could cause degradation of waterproof performance.
 *To insert the waterproof pin over the target dimension, it has the possibility to fall to a low level of waterproof.

Target (1.55 mm)

Target (1.85 mm)

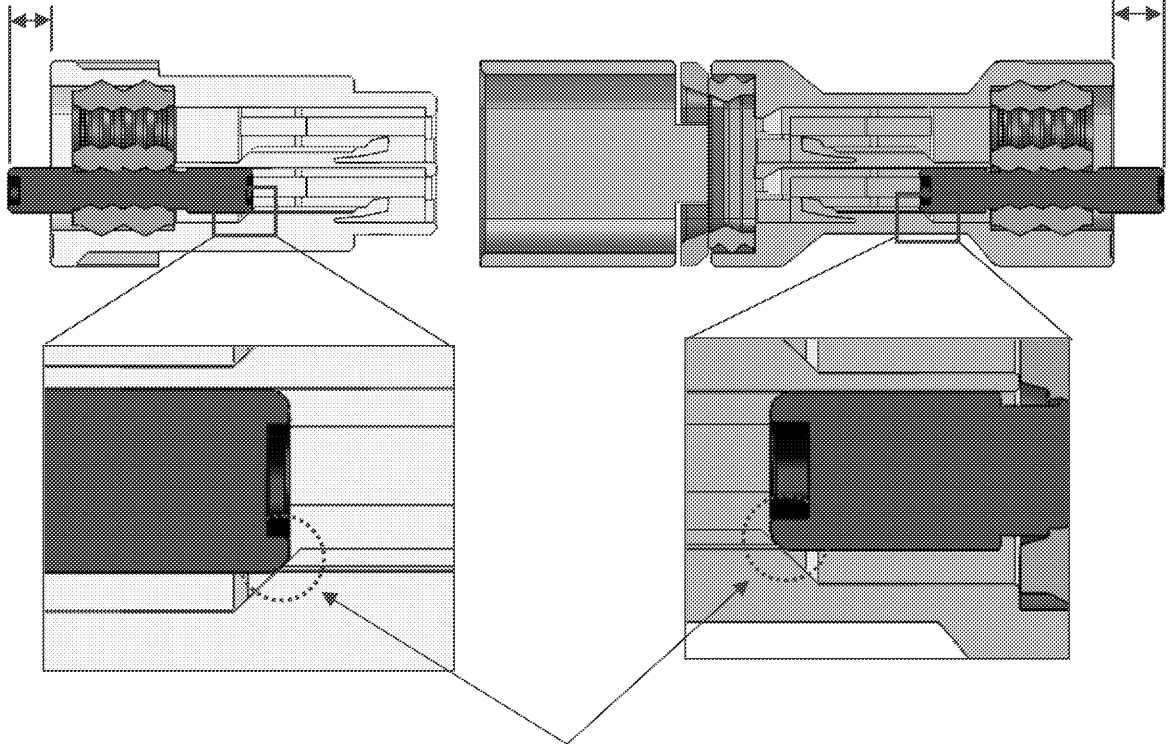

To tap the waterproof pin to socket.

3.5. Repair of crimped terminal

To remove crimped terminals that have been inserted, pull the cable using the dedicated Removing jig (DF62W/RE-MD) while pushing up the crimping socket lance.

Using crimping socket after repair could induce decrease of lance strength and / or wire seal damage. Use new socket to avoid such failures.

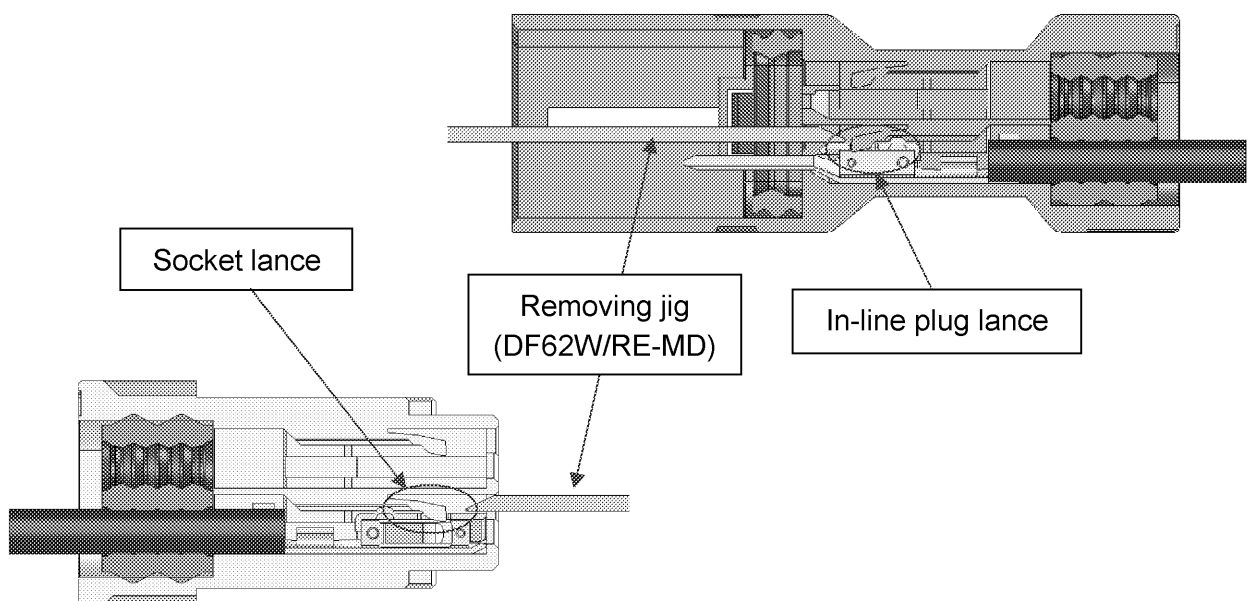

- Insert the removing jig along the lance of crimping socket.
(Check the appearance with the hand lens.)

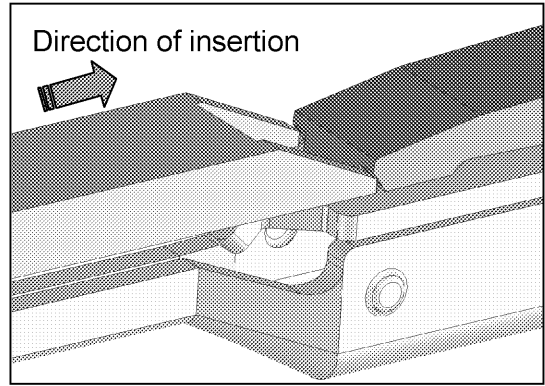
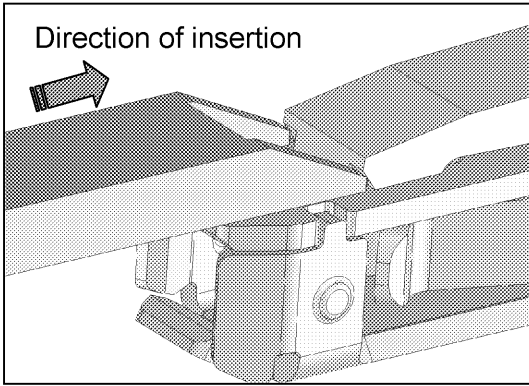
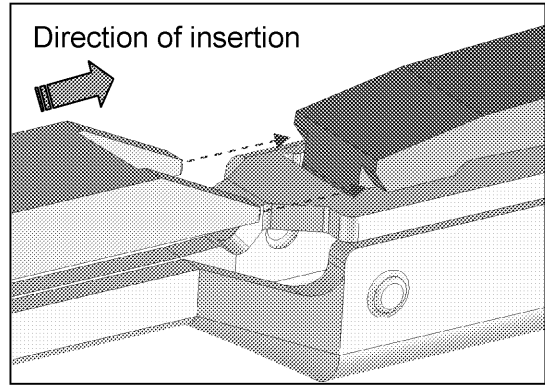
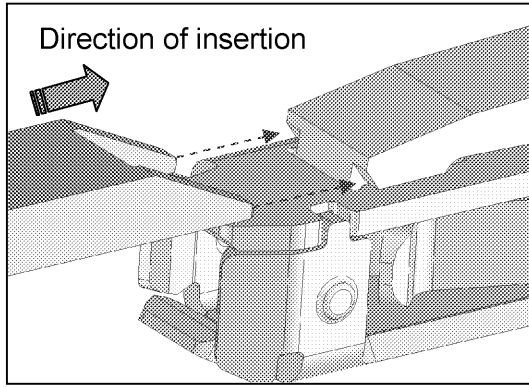

- Additionally insert the removing jig to push up the socket lance.
Keep the lance position and pull the cable.

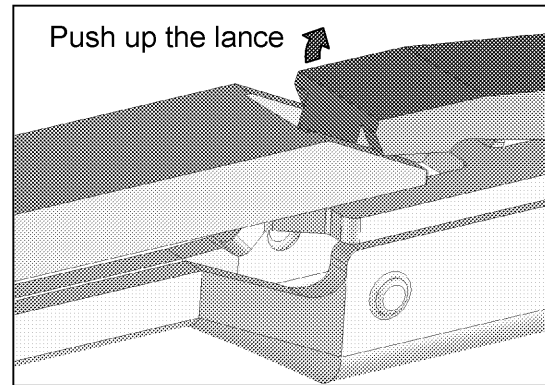
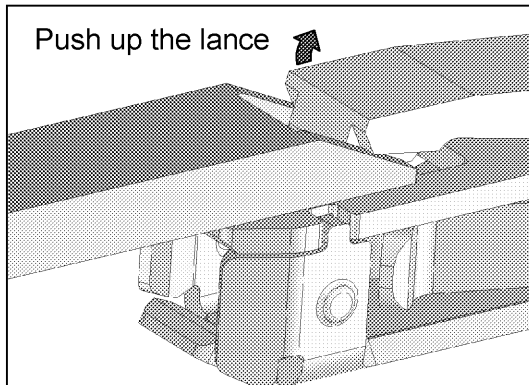

4. Precautions for handling



*Packing and storage

To pack or store assemblies, make sure overlapped connectors will not apply extreme load to the lock section.

If load is applied to the lock section under high temperature and humidity for a long period of time, the lock section will be deformed which could lead poor fitting.

*Excessive external force applied to connectors could cause failure or damage. Therefore, avoid forced insertion or removal, dropping impact, cable wiring (pull, twist) and such.

Note) Breaking strength of lock is approx. 50 N when connector is pulled in straight direction. Please avoid excessive force is applied to the connector.

Note) Retention force is approx. 10 N / Pin. Please avoid excessive force is applied to particular cable.

⚠ *If the rubber seal is damaged, the connector is deteriorated water resistant performance. Therefore, do not use the connector whose rubber seal is damaged.

*During cable wiring inside the machine, keep sufficient cable length for slack to avoid direct stress is applied to the connector.

*Forcible wiring such as bending the cable near the connector and straining the cable, could cause contact failure and / or waterproof defect.

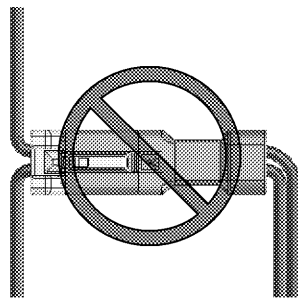

Bending near the connector

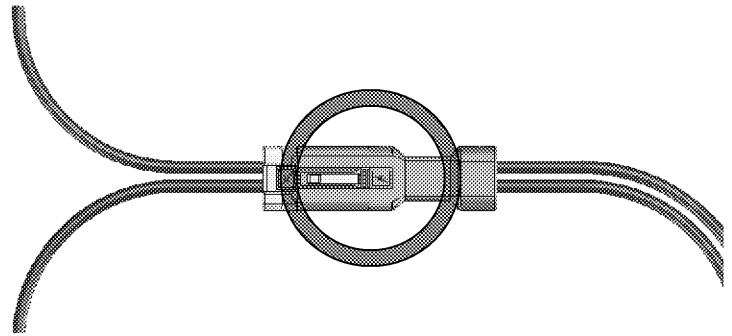

Sufficient cable length for slack