

KM32 Series

2.0mm Pitch, 0.5 Size, Wire-to-Board Connector



P=2.0 mm



Space-Saving



Automotive

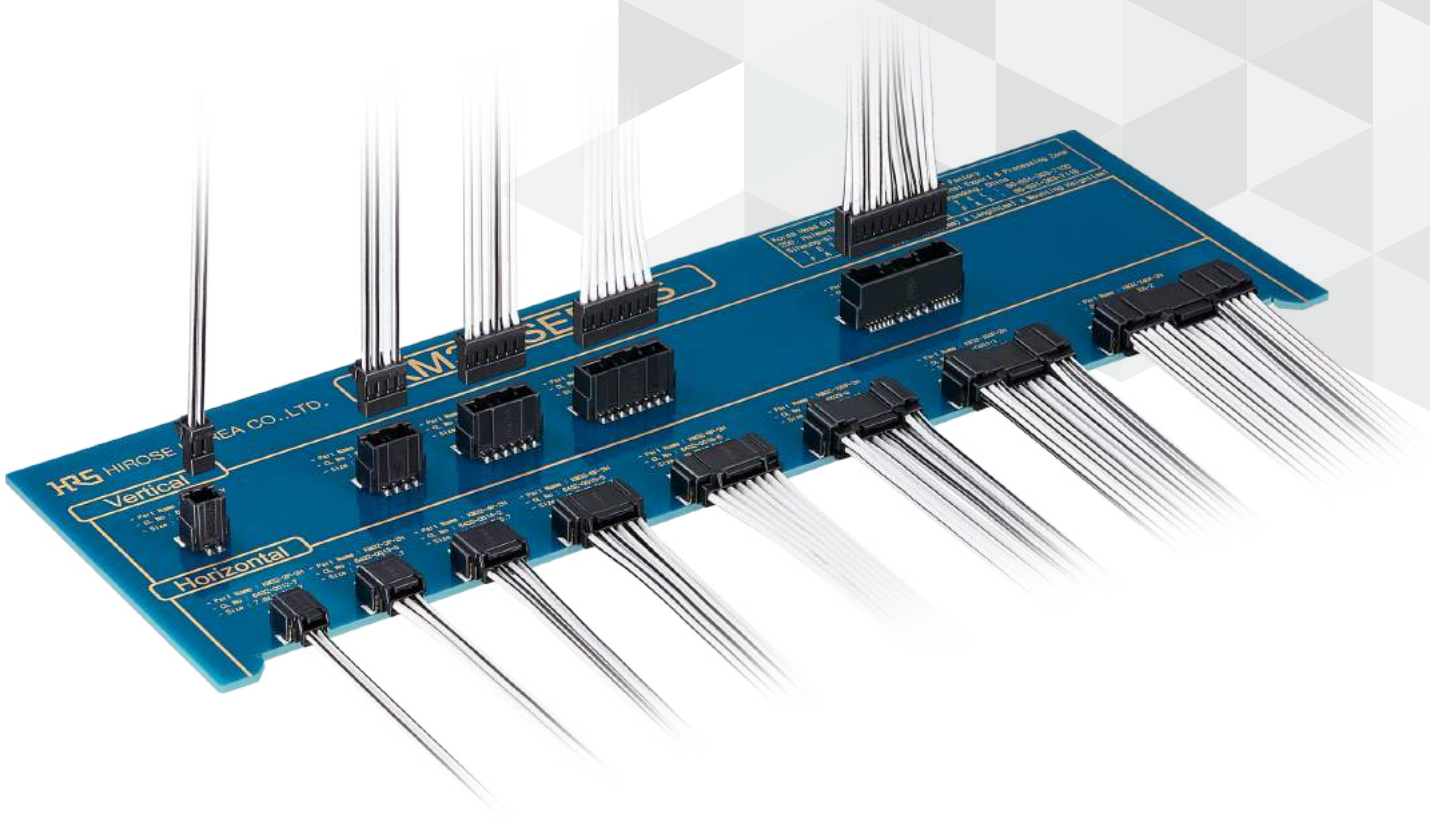

Features

1. Space-saving and Wide Variations

Space-saving design that contributes to size reduction of end product.

Multiple variations are available.

- Interface Types: Straight / Right Angle
- Single-row / Double-row

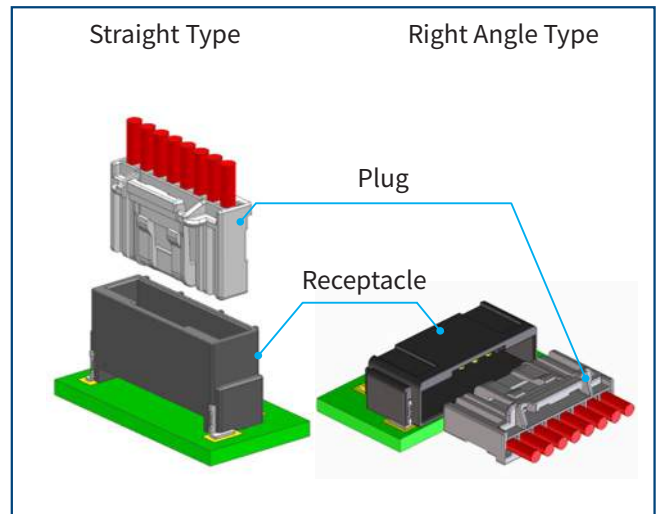

Mated Combination (e. g. : Single-row, 8pos.)

2. Meets severe automotive requirements

3. Excellent contact retention within a compact size

Has a lance strength of 40N maximum without retainer.
Robust Design for Secure Cable Routing

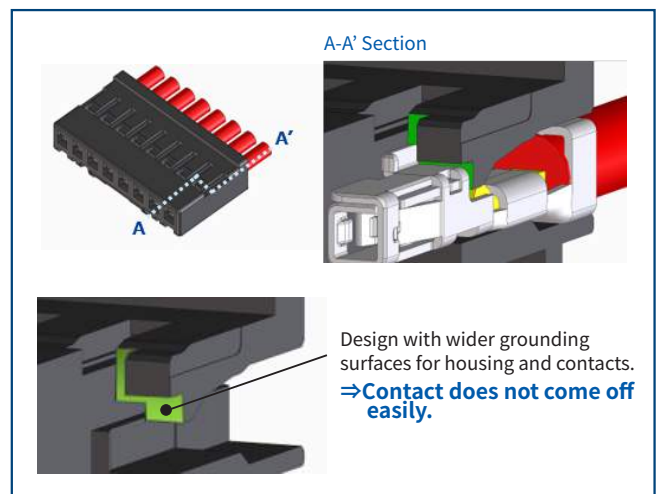

Contact Retention Design

4. High contact reliability with long effective mating length and 2-point contact design

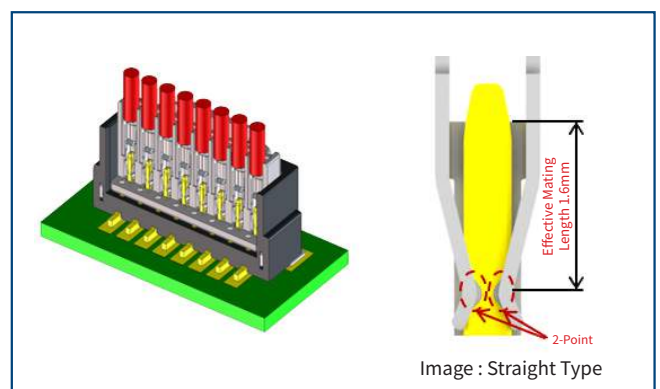

Terminal Contact Design

5. Safety design with center lock prevents incomplete mating, misinsertion and lock damage

Product Specifications

Rated Current	3A	Operating Temperature (Note 1)	-40 to +85° C
Rated Voltage	250V DC		

Items	Specifications	Conditions
Voltage Drop	Initial : 30mΩ Max. After Testing : 50mΩ Max.	Measured at 20 ± 5mV, 10mA
Insulation Resistance	Initial : 100MΩ Min. After Testing : 10MΩ Min.	Measured at 500V DC
Withstanding Voltage	No insulation breakdown.	500V AC for 1 min.
Mating Durability	Voltage Drop: Initial : 30mΩ Max. After Testing : 50mΩ Max.	10 times
Temperature Cycle	Voltage Drop: Initial : 30mΩ Max. After Testing : 50mΩ Max.	Temperature : +85°C → Room temperature → -40°C → Room temperature Time : 30 → 5 → 30 → 5 minutes for 200 cycles
Insertion and Removal Force	76N Max.	Measure force by inserting and disengaging the connector at constant 50 mm/min speed.

Note 1 : Includes the temperature rise due to current flow.

Note 2 : Please refer to the specification sheet for details.

Materials / Finish

Product	Component	Materials	Color / Finish
Receptacle	Insulator	PPS	Black
	Male Contact	Brass	Tin Plating (Nickel Underplated)
	Retention Tab	Brass	Tin Plating (Nickel Underplated)
Plug	Insulator	PA66	Black
Crimp Contact	Female Contact	Copper Alloy	Tin Plating

Product Number Structure

Refer to the chart below when determining the product specifications from the product number.
Please select from the product numbers listed in this catalog when placing orders.

Receptacle / Plug

KM32 - 16 D P - 2 H (BL) (800)
 ① ② ③ ④ ⑤ ⑥ ⑨

Crimp Contact

KM32 - 22 SCF (L) (800)
 ① ⑦ ⑧ ⑨

① Series Name	KM32	⑥ Terminal Type	H : Right Angle SMT V : Straight SMT HU : Plug Socket
② No. of Pos.	Single-row : 2, 3, 4, 6, 8 Double-row : 12, 16, 24		
③ Row	None : Single-row D : Double-row	⑦ Applicable Wire Size	22 AWG
④ Connector Type	P : Receptacle S : Plug	⑧ Contact Type / Packaging Method	Female Contact / Reel
⑤ Contact Pitch	2mm	⑨ Specification	Standard

Right Angle Receptacle

Single-row

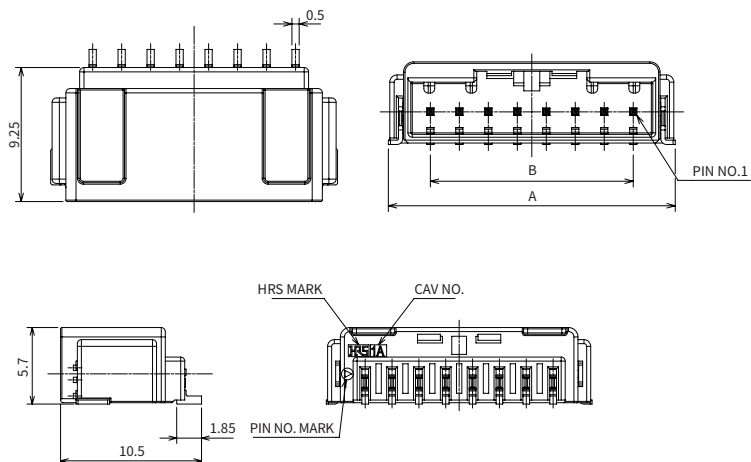

Recommended PCB Pattern (t=1.6mm)

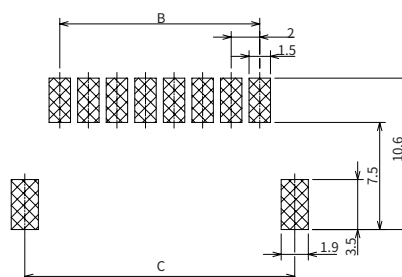

Unit:mm

Part No.	HRS No.	No. of Pos.	A	B	C	Purchase Unit
KM32-2P-2H(BL)(800)	CL0480-0740-0-00	2	7.8	2.0	6.9	900pcs per reel
KM32-3P-2H(BL)(800)	CL0480-0741-0-00	3	9.8	4.0	8.9	
KM32-4P-2H(BL)(800)	CL0480-0742-0-00	4	11.8	6.0	10.9	
KM32-6P-2H(BL)(800)	CL0480-0743-0-00	6	15.8	10.0	14.9	
KM32-8P-2H(BL)(800)	CL0480-0744-0-00	8	19.8	14.0	18.9	

Double-row

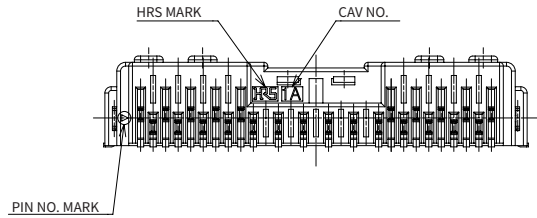
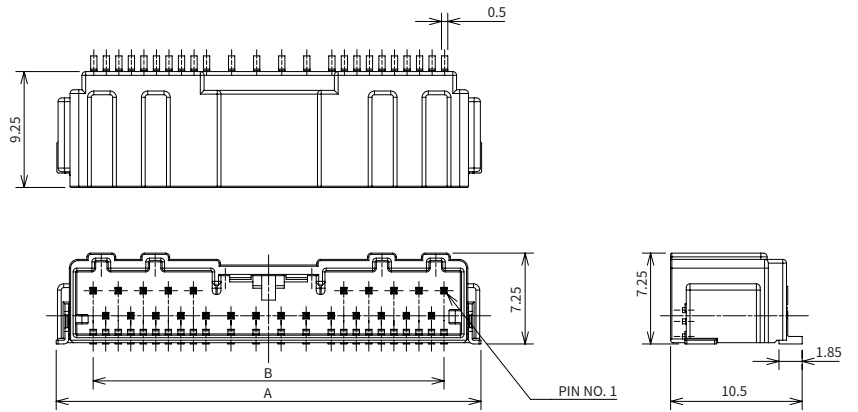
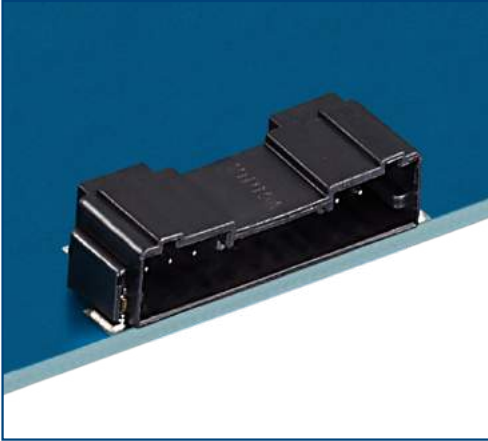

Recommended PCB Pattern (t=1.6mm)

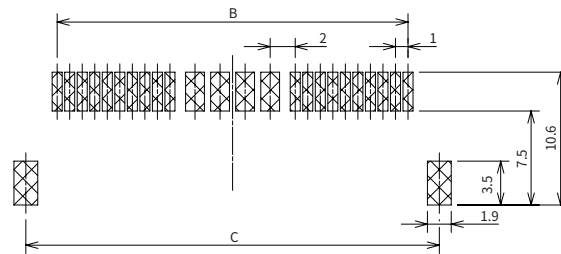

Unit:mm

Part No.	HRS No.	No. of Pos.	A	B	C	Purchase Unit
KM32-12DP-2H(BL)(800)	CL0480-0539-0-00	12	21.9	16.0	21.0	750pcs per reel
KM32-16DP-2H(BL)(800)	CL0480-0745-0-00	16	25.9	20.0	25.0	
KM32-24DP-2H(BL)(800)	CL0480-0746-0-00	24	33.9	28.0	33.0	700pcs per reel

Straight Receptacle

Single-row

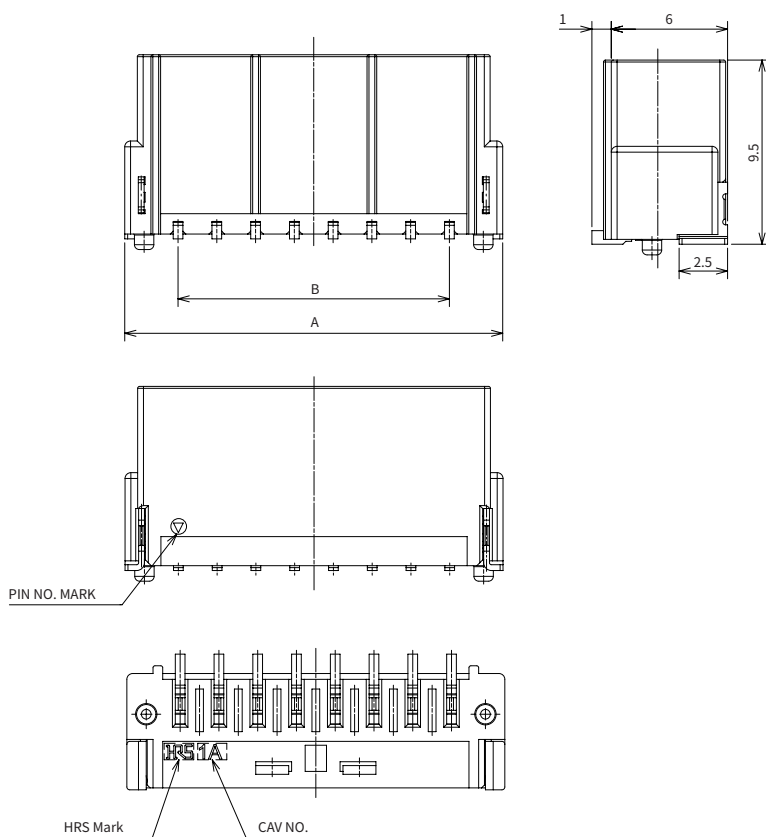

Recommended PCB Pattern (t=1.6mm)

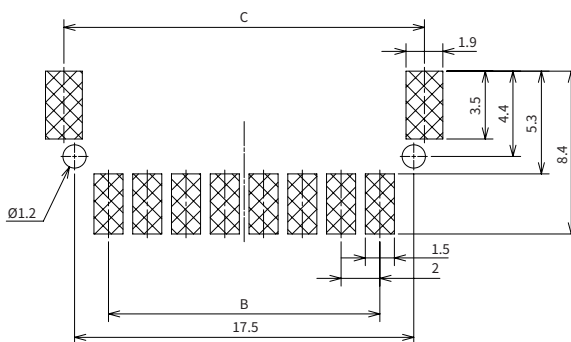

Unit : mm

Part No.	HRS No.	No. of Pos.	A	B	C	Purchase Unit
KM32-2P-2V(BL)(800)	CL0480-0747-0-00	2	7.5	2.0	6.6	500pcs per reel
KM32-4P-2V(BL)(800)	CL0480-0748-0-00	4	11.5	6.0	10.6	
KM32-6P-2V(BL)(800)	CL0480-0749-0-00	6	15.5	10.0	14.6	
KM32-8P-2V(BL)(800)	CL0480-0750-0-00	8	19.5	14.0	18.6	

Double-row

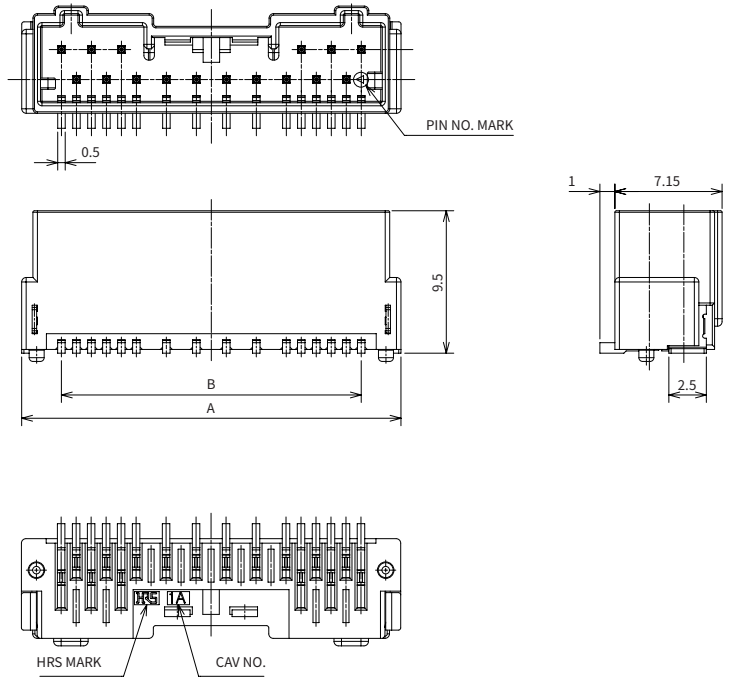

Recommended PCB Pattern (t=1.6mm)

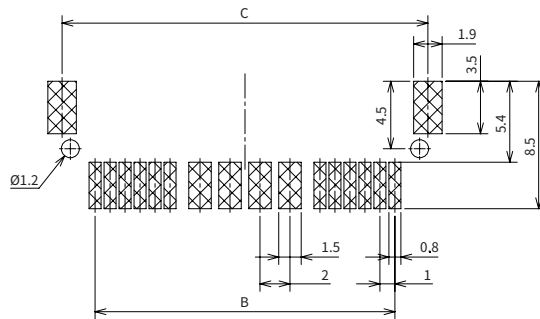

Unit : mm

Part No.	HRS No.	No. of Pos.	A	B	C	Purchase Unit
KM32-16DP-2V(BL)(800)	CL0480-0751-0-00	16	25.3	20.0	24.4	500pcs per reel

Plug

Single-row



Shown with crimp contact inserted.

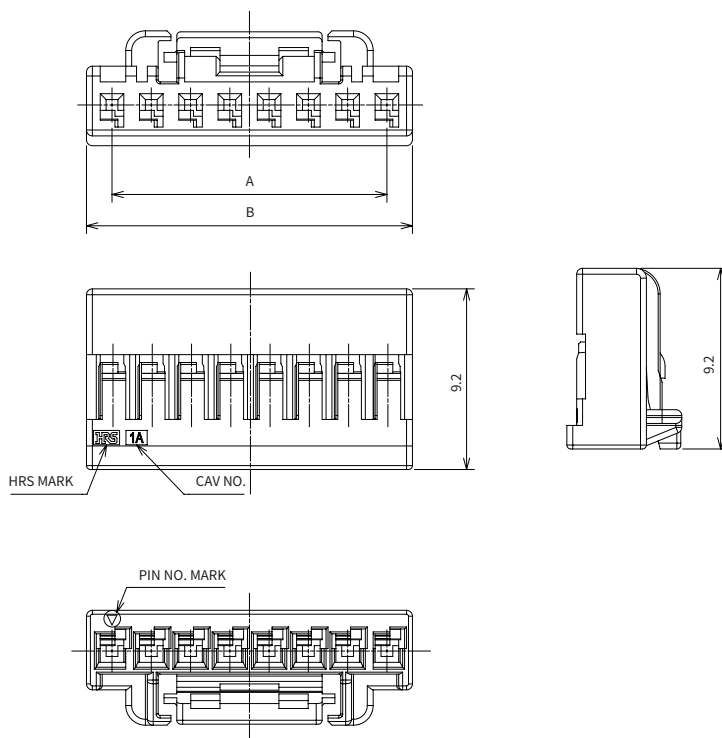

Mar.1.2024 Copyright 2024 HIROSE ELECTRIC CO., LTD. All Rights Reserved.

Unit : mm

Part No.	HRS No.	No. of Pos.	A	B	Purchase Unit
KM32-2S-HU(BL)(800)	CL0480-0734-0-00	2	4.6	2.0	4000pcs per bag
KM32-3S-HU(BL)(800)	CL0480-0735-0-00	3	6.6	4.0	
KM32-4S-HU(BL)(800)	CL0480-0736-0-00	4	8.6	6.0	
KM32-6S-HU(BL)(800)	CL0480-0608-0-00	6	12.6	10.0	
KM32-8S-HU(BL)(800)	CL0480-0737-0-00	8	16.6	14.0	

Double-row



Shown with crimp contact inserted.

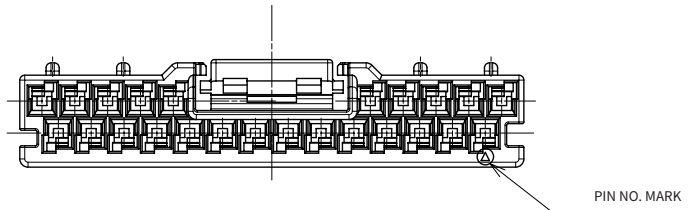
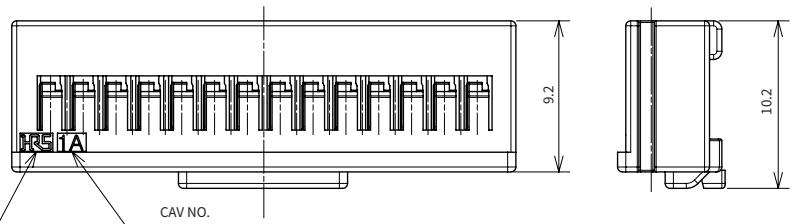
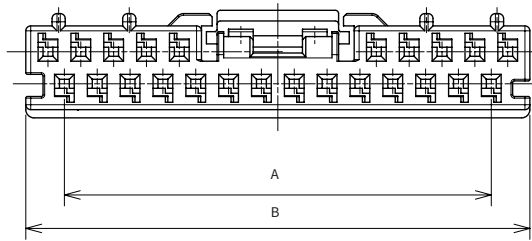

Unit : mm

Part No.	HRS No.	No. of Pos.	A	B	Purchase Unit
KM32-12DS-HU(BL)(800)	CL0480-0538-0-00	12	18.7	16.0	2000pcs per bag
KM32-16DS-HU(BL)(800)	CL0480-0738-0-00	16	22.7	20.0	
KM32-24DS-HU(BL)(800)	CL0480-0739-0-00	24	30.7	28.0	1000pcs per bag

Crimp Contact

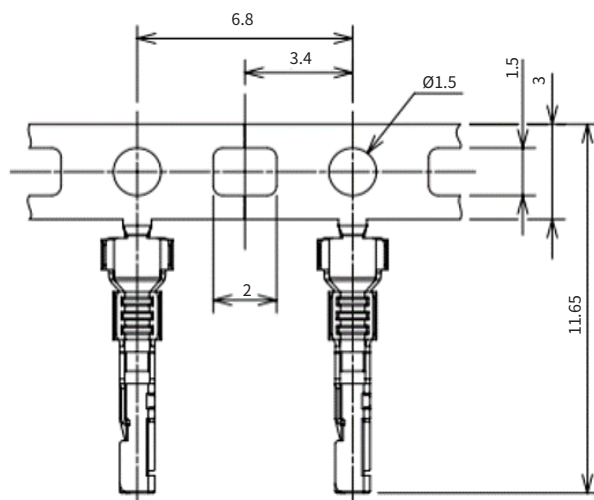
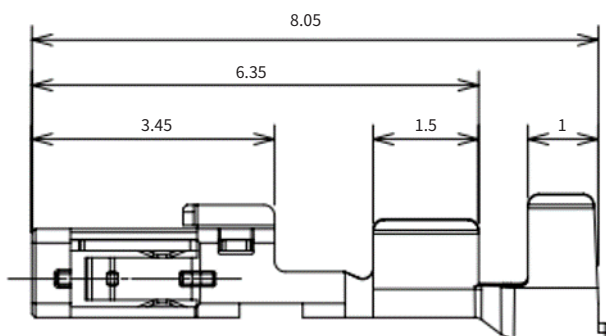

Part No.	HRS No.	Applicable Cable	Purchase Unit
KM32-22SCF(L)(800)	CL0480-0752-0-00	Wire Size: 22 AWG Jacket Outer Diameter: Ø1.4 to 1.5	7000pcs per reel

Mated Dimensions Diagram

Right Angle Receptacle to Plug Connection

Straight Receptacle to Plug Connection

Single-row

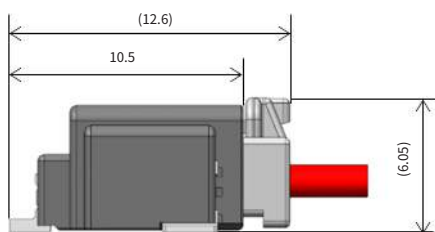

Single-row

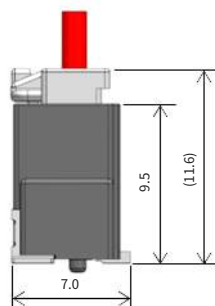

Double-row

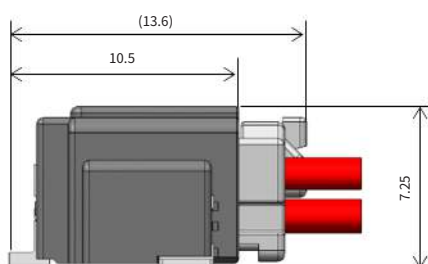

Double-row

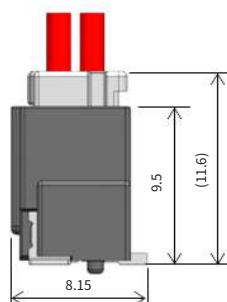

Applicable Crimping Tools

Type	Part No.	HRS No.	Applicable Contact
Automatic Crimp Press	CM-105C	CL0901-0001-0-00	-
Applicator	AP105-KM32-2022S	CL0901-5252-0-00	KM32-22SCF(L)(800)

Note 1 : Please conduct crimping work according to the Crimp Quality Standard and the Crimp Condition Table.

Note 2 : Any problems that occur from using tools other than those specified by Hirose are not covered by the warranty.

Usage Precautions

<p>Recommended Temperature Profile</p>	<p>[Conditions] 1. Heating : 260°C± 5°C , 30 sec. 2. Preheating : 150 to 180°C , 60 to 120 sec. 3. Number of Reflow Cycles : 3 cycles Max.</p> <p>*Measurement is conducted at the contact lead part. Soldering results may change depending on conditions such as solder paste type, manufacturer, PCB size, and other soldering materials. Please determine all mounting conditions before use. *This temperature profile is a recommended value.</p>
<p>Cautions</p>	<ol style="list-style-type: none"> 1. Forcing the connector out might cause damage. If challenging to remove, gently press down once and then release the lock. 2. Always disconnect the power before reseating the connector. 3. Avoid touching the terminal area when the power is active, as it's hazardous. 4. For harnessing guidelines, please consult a Hirose representative.

While Taking into Consideration

Specifications mentioned in this catalog are reference values.

When considering to order or use this product, please review the Drawing and Product Specifications sheets.

Use an appropriate cable when using the connector in combination with cables.

If considering usage of a non- specified cable, please contact your sales representative.

If assembly process is done by jigs & tools which are not identified by Hirose, the warranty of the product may be affected.

If considering usage for below mentioned applications, please contact your sales representative.

In cases where the application will demand a high level of reliability, such as automotive, medical instruments,

Public infrastructure, aerospace/ defense etc. Hirose must review before assurance of reliability can be given.