

TF70 Series

For Automotive, 0.5mm Pitch, Center Lock, FPC/FFC-to-Board Connector

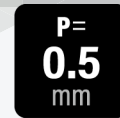

P= 0.5mm



Finger Protect



Automotive

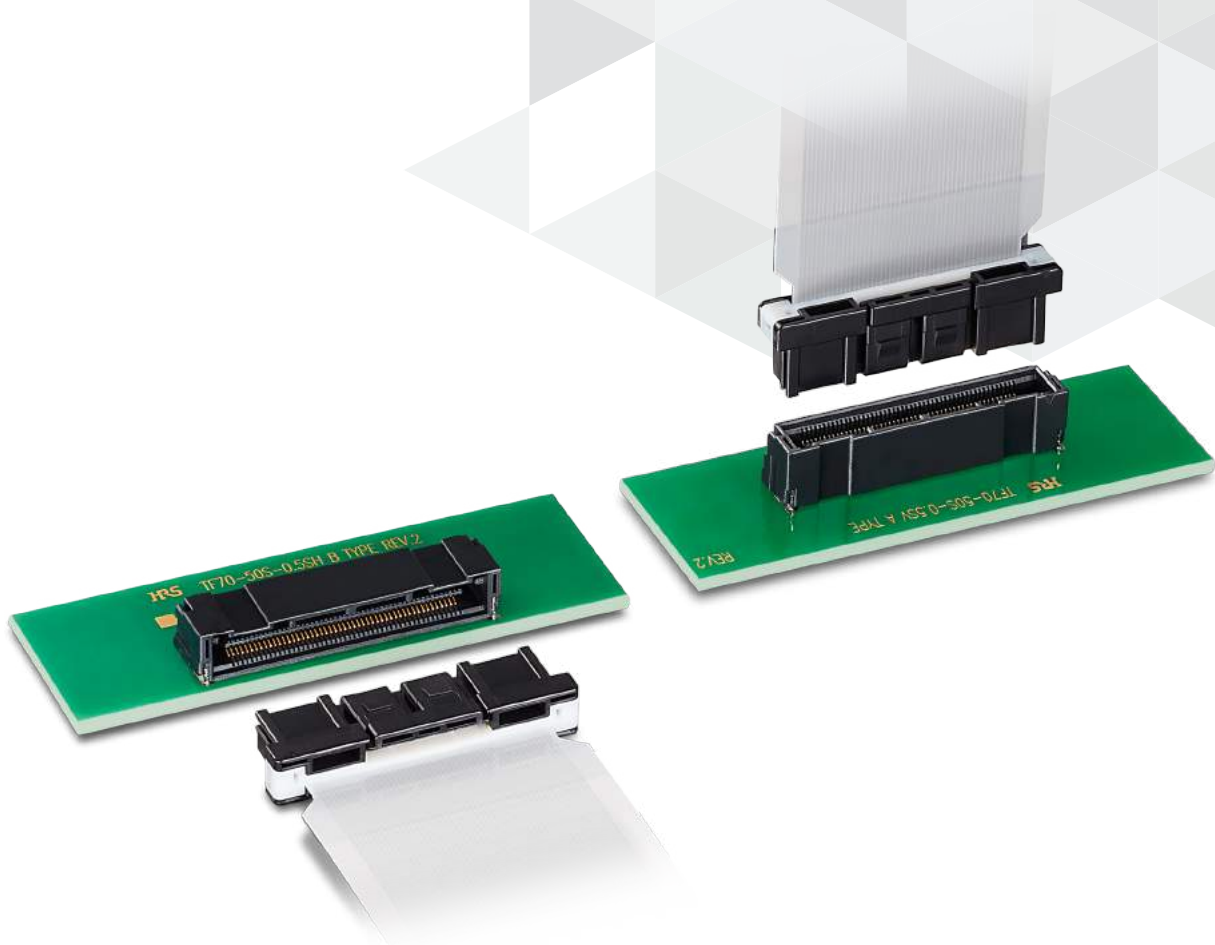

Product Page
<https://www.hirose.com/en/product/series/TF70>

May.1.2024 Copyright 2024 HIROSE ELECTRIC CO., LTD. All Rights Reserved.

Features

1. Narrow Pitch and Compact Design

This two-piece FPC/FFC-to-board connector, with a 0.5mm pitch for FPC/FFC and PCB patterns, significantly reduces the size and weight of the end product.

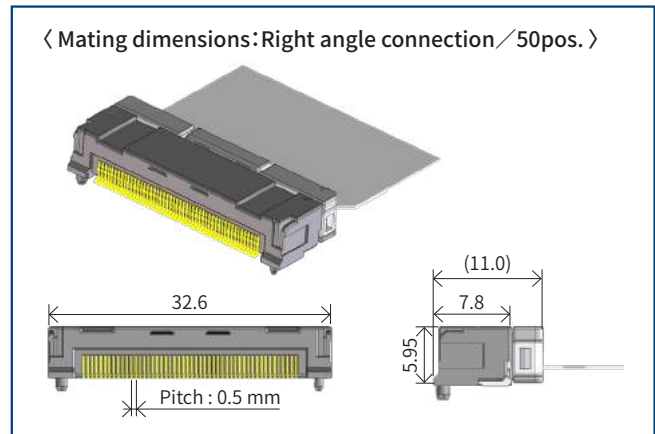

2. Direct FPC/FFC connection design streamlines assembly and reduces size and weight.

Assembly involves simply inserting the FPC/FFC into the plug housing and securing with the retainer, enhancing efficiency and reducing complexity. This design eliminates traditional terminals, thereby decreasing weight and conserving space by using FPC/FFC instead of discrete wires.

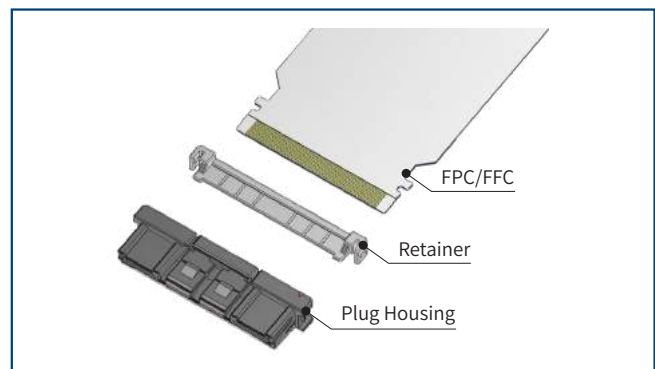

3. Offers both right angle and straight angle connection methods for flexible board design.

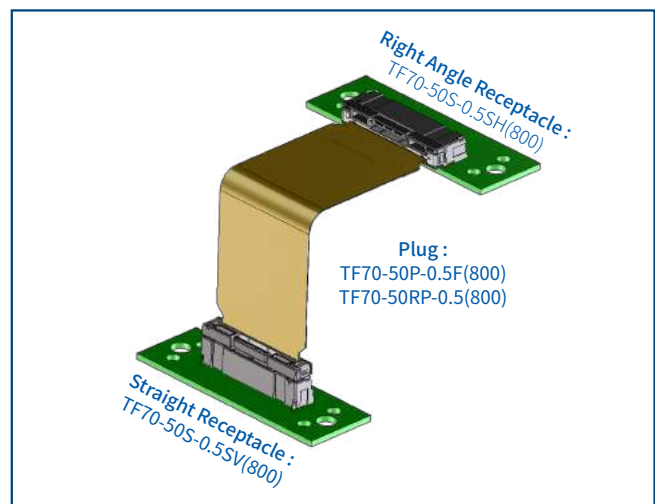

4. Center Lock Design

Center Lock Design allows for easy, one-handed insertion and removal, ensuring durable performance with a locking strength of over 40N.

5. Safe design features prevent electric shock, mis-insertion, and incorrect mounting.

Product Specifications

Rated Current (Note 1)	0.5A	Operating Temperature (Note 2)	-40 to +105°C
Rated Voltage	50V AC/DC	Operating Humidity Range	Relative Humidity 90% Max. (No condensation)
		Storage Temperature (Note 3)	-10 to +50°C
		Storage Humidity Range	Relative Humidity 90% Max. (No condensation)

Adaptive FPC/FFC Contact Specifications	Thickness : 0.3 ± 0.03mm Gold Plated Contact Traces
---	---

Items	Specifications	Conditions
Contact Resistance	Initial : 50mΩ Max. After Testing : 70mΩ Max.	1mA (20mV AC)
Insulation Resistance	500MΩ Min.	100V DC
Withstanding Voltage	No insulation breakdown	150V AC for 1 min.
Mating Durability	Contact Resistance : 70mΩ Max.	20 cycles
Vibration Resistance	No electrical discontinuity of 1μs or more Contact Resistance : 70mΩ Max.	Frequency 10 to 60Hz, amplitude of 0.7mm Frequency 60 to 500Hz, acceleration of 49m/s ² , 1 cycle : 11 min. (1oct/min.) Test for 8 hours each in 3 axial directions
Shock Resistance	No electrical discontinuity of 1μs or more Contact Resistance : 70mΩ Max.	Acceleration : 981m/s ² , duration : 6ms Test 3 times in 3 axial directions
Humidity Resistance	Contact Resistance : 70mΩ Max. Insulation Resistance : 250MΩ Min. Withstanding Voltage : No insulation breakdown	Exposed at temperature of 60±2°C and humidity of 90 to 95% for 1,000h
Temperature Cycle	Contact Resistance : 70mΩ Max.	Temperature: -40±3 → +15 to +35 → +105±3 → +15to +35°C Time : 30 → 2 to 3 → 30 → 2 to 3 min. for 1,000 cycles
Heat Resistance	Contact Resistance : 70mΩ Max.	Exposed at 105±3°C for 1,000h
Cold Resistance	Contact Resistance : 70mΩ Max.	Exposed at -40±3°C for 1,000h
Sulfurous Acid Gas Resistance	Contact Resistance : 70mΩ Max.	Exposed at 40±2°C with a concentration of 25±5ppm and relative humidity 80±5% for 96h

Note 1 : When passing the current through all of the contacts, use 70% of the current rating.

Note 2 : Includes temperature rise caused by current flow. If the heat resistance of the FPC/FFC is less than 105°C, the heat resistance of the FPC/FFC is applied.

Note 3 : The term "storage" refers to products stored for long period of time prior to mounting and use.

Operating temperature range and Humidity range covers non-conducting condition of installed connectors in storage, shipment or during transportation.

Materials / Finish

Component		Materials	Finish and Color
Receptacle	Insulation	LCP	Black
	Contact	Copper Alloy	Gold plated (Nickel Underplating)
	Retention Tab	Brass	Tin Plated (Nickel Underplating)
Plug	Housing	PBT	Black
	Retainer	PBT	White

Product Number Structure

Refer to the chart below when determining the product specifications from the product number.

TF70 - **50** **S** - **0.5** **SH** **(800)**

① ② ③ ④ ⑤ ⑥

① Series Name	TF70	④ Pitch	0.5mm
② No. of Pos.	50pos.	⑤ Product Type	SH : SMT Horizontal Mounting Type SV : SMT Vertical Mounting Type F : FPC/FFC Plug
③ Connector Type	S : Receptacle P : Plug RP : Retainer		

Right Angle Receptacle

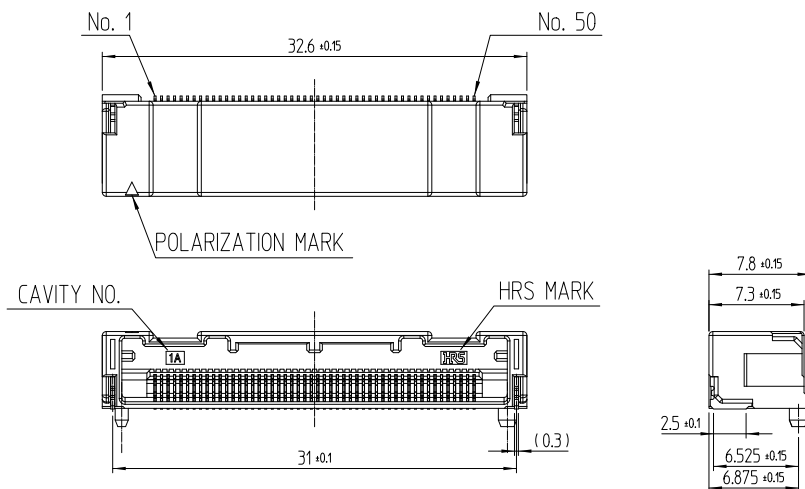
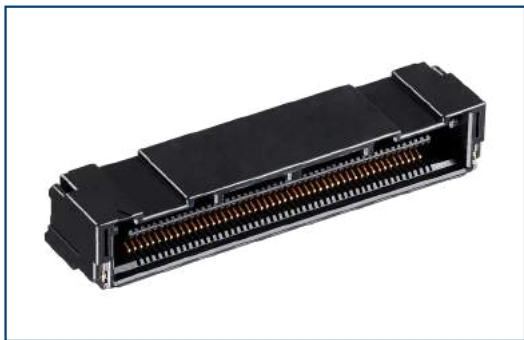

Part No.	HRS No.	No. of Pos.	Purchase Unit
TF70-50S-0.5SH(800)	CL0480-1082-0-00	50	650pcs per reel

- Recommended Land / Metal Mask Dimensions
(Recommended Metal Mask Thickness: 0.12mm)

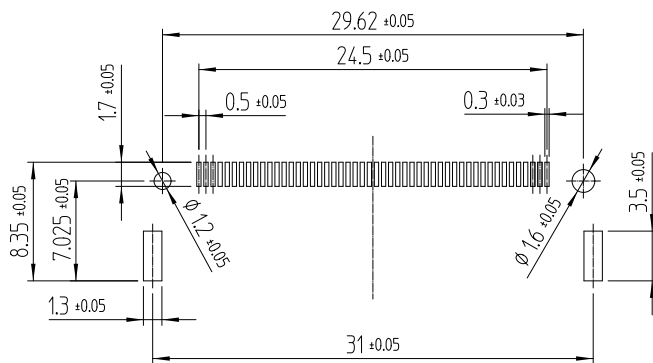

Straight Receptacle

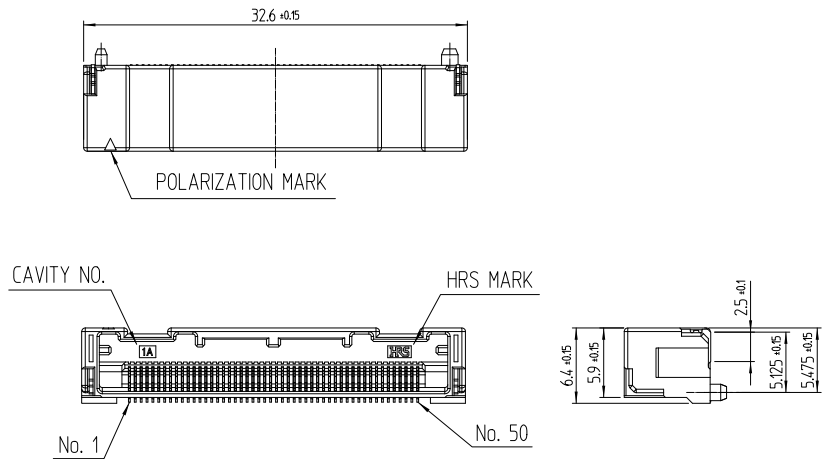
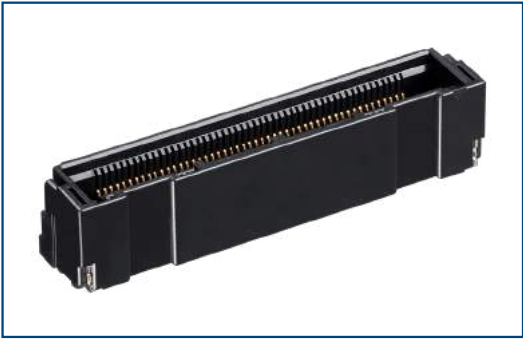

Part No.	HRS No.	No. of Pos.	Purchase Unit
TF70-50S-0.5SV(800)	CL0480-0983-0-00	50	500pcs per reel

- Recommended Land / Metal Mask Dimensions
(Recommended Metal Mask Thickness: 0.12mm)

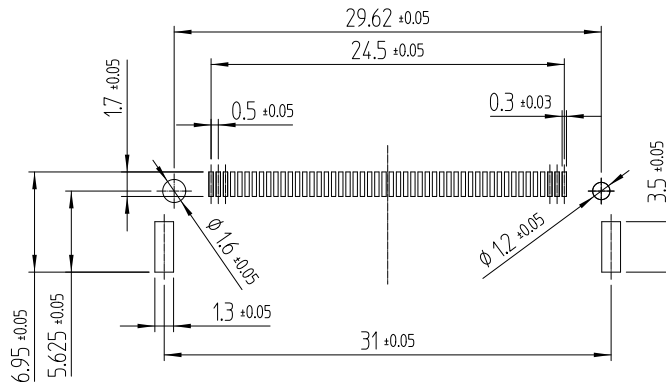

Plug Housing

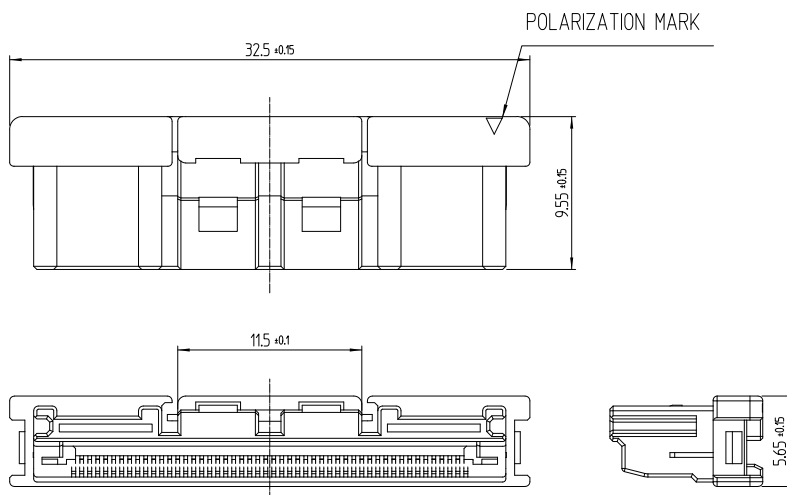

Part No.	HRS No.	No. of Pos.	Purchase Unit
TF70-50P-0.5F(800)	CL0480-0982-0-00	50	300pcs per bag

Note : Use with the retainer (TF70-50RP-0.5(800)), sold separately.

Retainer

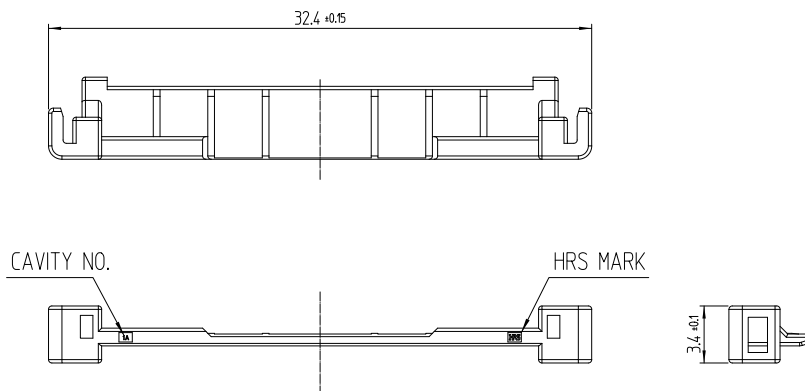

Part No.	HRS No.	No. of Pos.	Purchase Unit
TF70-50RP-0.5(800)	CL0480-0984-0-00	50	1,000pcs per bag

Note : Attach to the plug housing (TF70-50P-0.5F(800)), sold separately.

Usage Precautions

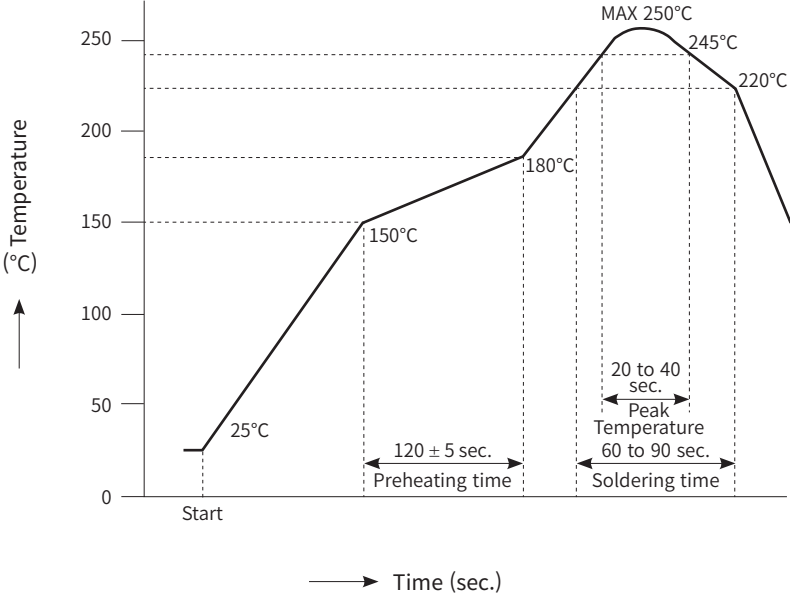
<p>Recommended Temperature Profile</p>	 <p>*Measurements are taken at the contact lead. Results may vary based on factors like solder paste type, manufacturer, PCB size, and other soldering materials. Ensure all mounting conditions are determined before use.</p> <p>*The provided temperature profile is recommended.</p>
<p>Cautions</p>	<ol style="list-style-type: none"> 1. Forcing the connector out might cause damage. If challenging to remove, gently press down once and then release the lock. 2. Always disconnect the power before reseating the connector. 3. Avoid touching the terminal area when the power is active, as it's hazardous. 4. For harnessing guidelines, please consult a Hirose representative.

While Taking into Consideration

Specifications mentioned in this catalog are reference values.

When considering to order or use this product, please review the Drawing and Product Specifications sheets.

Use an appropriate cable when using the connector in combination with cables.

If considering usage of a non-specified cable, please contact your sales representative.

If assembly process is done by jigs & tools which are not identified by Hirose, the warranty of the product may be affected.

If considering usage for below mentioned applications, please contact your sales representative.

In cases where the application will demand a high level of reliability, such as automotive, medical instruments, public infrastructure, aerospace/defense etc. Hirose must review before assurance of reliability can be given.