

May.1.2021 Copyright 2021 HIROSE ELECTRIC CO., LTD. All Rights Reserved.
In case of consideration for using Automotive equipment / device which demand high reliability, kindly contact our sales window correspondents.

1		2			3			4		
COUNT	DESCRIPTION OF REVISIONS	BY	CHKD	DATE	COUNT	DESCRIPTION OF REVISIONS	BY	CHKD	DATE	
△					△					
△					△					
△					△					

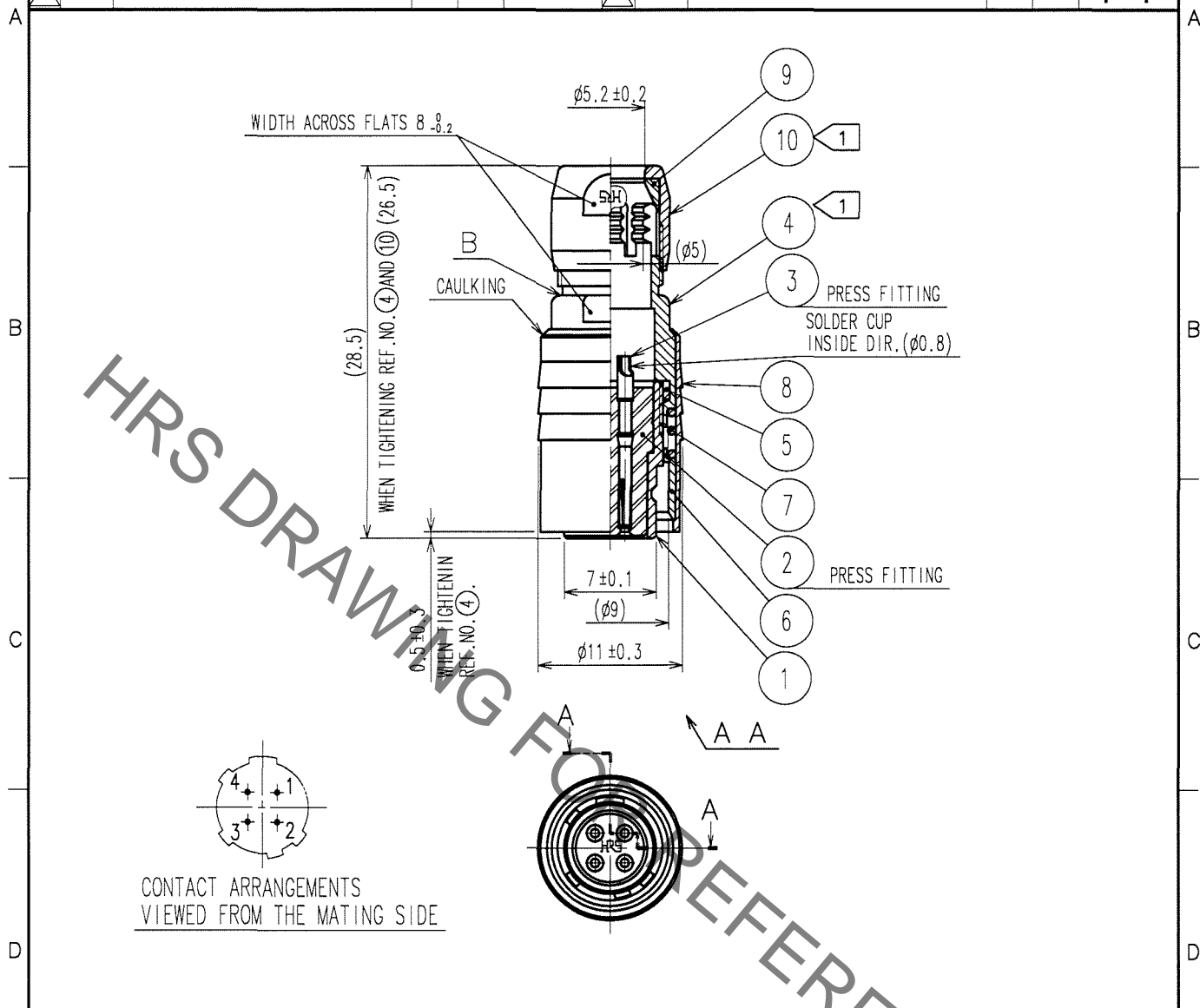

HRS DRAWING FOR REFERENCE

NOTES ① THE RECOMMENDED CLAMP TORQUE, REF. NO. ④ AND ⑩ : 1.5 N · m.
REF. NO. ⑩ SHALL BE TIGHTENED BY TORQUE AFTER CLAMPED UNTIL IT TOUCHES THE SURFACE B.
2 ONE EXAMPLE OF THE ROTATION OF REF. NO. ①, ④ AND ⑩ ARE SHOWN.

5	POLYAMIDE		10	BRASS	MATTE FINISH NICKEL PLATED
4	BRASS	MATTE FINISH NICKEL PLATED	9	POLYAMIDE	
3	BERYLLIUM COPPER	GOLD PLATING 0.2μ m min. NICKEL UNDER PLATING 2μ m min.	8	BRASS	MATTE FINISH NICKEL PLATED
2	POLYAMIDE	(BLUE)	7	STEEL	NICKEL PLATING
1	ZINC ALLOY	MATTE FINISH NICKEL PLATED	6	STAINLESS STEEL	
NO.	MATERIAL	FINISH, REMARKS	NO.	MATERIAL	FINISH, REMARKS

CODE NO. (OLD)	CL	DRAWN	DESIGNED	CHECKED	APPROVED	RELEASED
		<i>D. Matsume</i>	<i>D. Matsume</i>	<i>E. Kunii</i>	<i>M. Saito</i>	
		06.04.03	06.04.03	06.04.04	06.04.04	

DRAWING NO.	PART NO.
EDC4-007757-73	HR10-7P-4S(73)
UNITS	CODE NO.
mm	CL110-0022-9-73

TO
R