

Oct.1.2021 Copyright 2021 HIROSE ELECTRIC CO., LTD. All Rights Reserved.
 In case of consideration for using Automotive equipment / device which demand high reliability, kindly contact our sales window correspondents.

1		2			3			4		
COUNT	DESCRIPTION OF REVISIONS	BY	CHKD	DATE	COUNT	DESCRIPTION OF REVISIONS	BY	CHKD	DATE	
△					△					
△					△					
△					△					

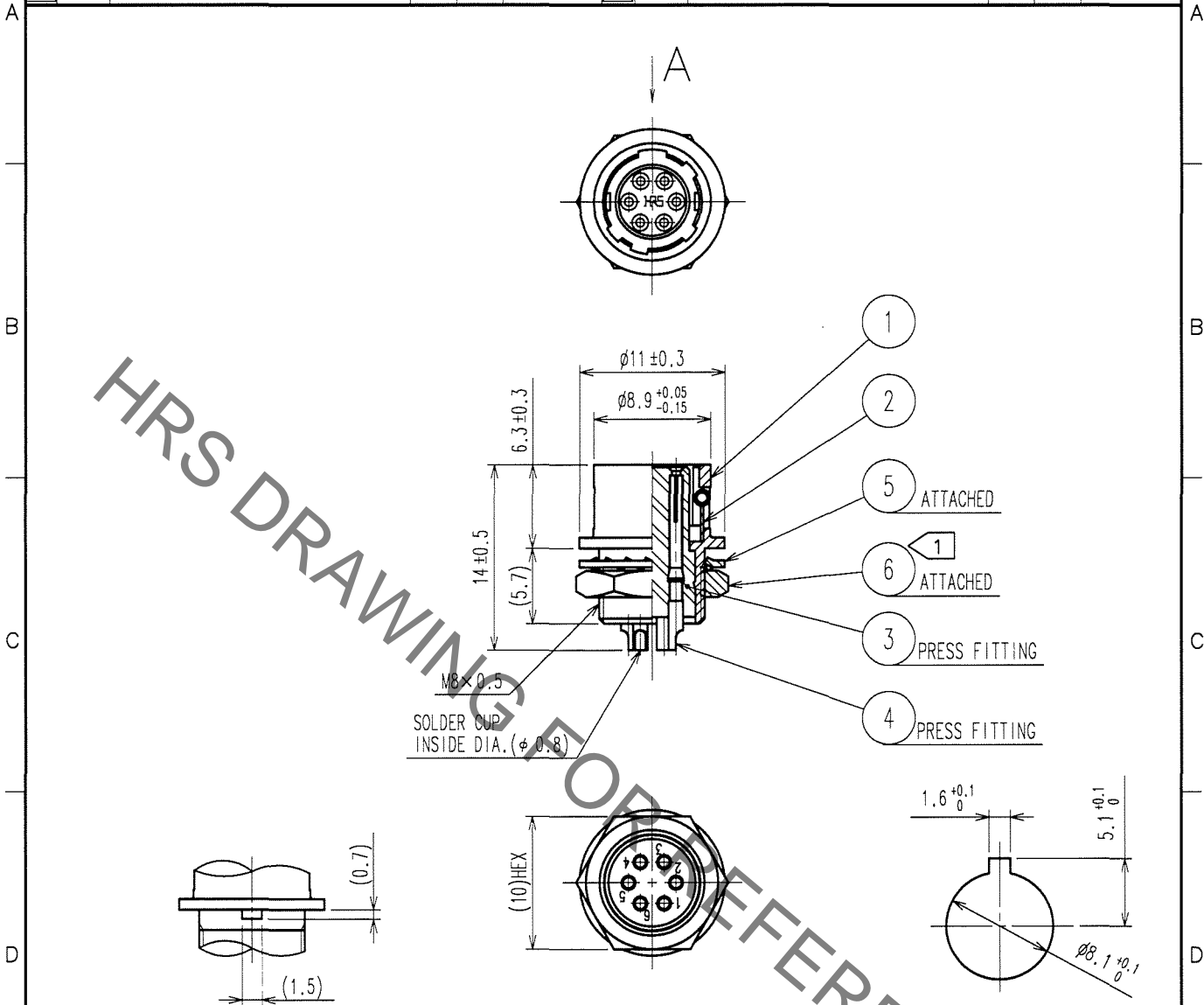

A DETAIL OF MOUNTING GUIDE

PANEL CUTOUT
 t = 0.7~2

NOTE ① THE RECOMMENDED CLAMP TORQUE OF REF. NO. ⑥ TO BE 1.5 N·m.
 LOCTITE 242, HENKEL JAPAN OR EQUIVALENT IS RECOMMENDED TO
 PREVENT REF. NO. ⑥ FROM LOOSENING.

NO.	MATERIAL	FINISH, REMARKS	NO.	MATERIAL	FINISH, REMARKS
3	POLYAMIDE	(BLUE)	6	BRASS	NICKEL PLATING
2	STAINLESS STEEL		5	PHOSPHOR BRONZE	NICKEL PLATING
1	ZINC ALLOY	MATTE FINISH NICKEL PLATED	4	BERYLLIUM COPPER	GOLD PLATING 0.2μm min. NICKEL UNDER PLATING 2μm min.

CODE NO. (OLD) CL	DRAWN S. Kawanishi 03.11.30	DESIGNED D. Matsume 05.11.30	CHECKED E. Kunii 05.11.30	APPROVED M. Sato 05.11.30	RELEASED
----------------------	-----------------------------------	------------------------------------	---------------------------------	---------------------------------	----------

	DRAWING NO. EDC4-007768-73	PART NO. HR10-7R-6S(73)
SCALE 2 : 1 UNITS mm	HIROSE ELECTRIC CO., LTD.	CODE NO. CL110-0033-5-73

TO
R