

May.1.2021 Copyright 2021 HIROSE ELECTRIC CO., LTD. All Rights Reserved.
In case of consideration for using Automotive equipment / device which demand high reliability, kindly contact our sales window correspondents.

1		2			3			4		
COUNT	DESCRIPTION OF REVISIONS	BY	CHKD	DATE	COUNT	DESCRIPTION OF REVISIONS	BY	CHKD	DATE	
△					△					
△					△					
△					△					

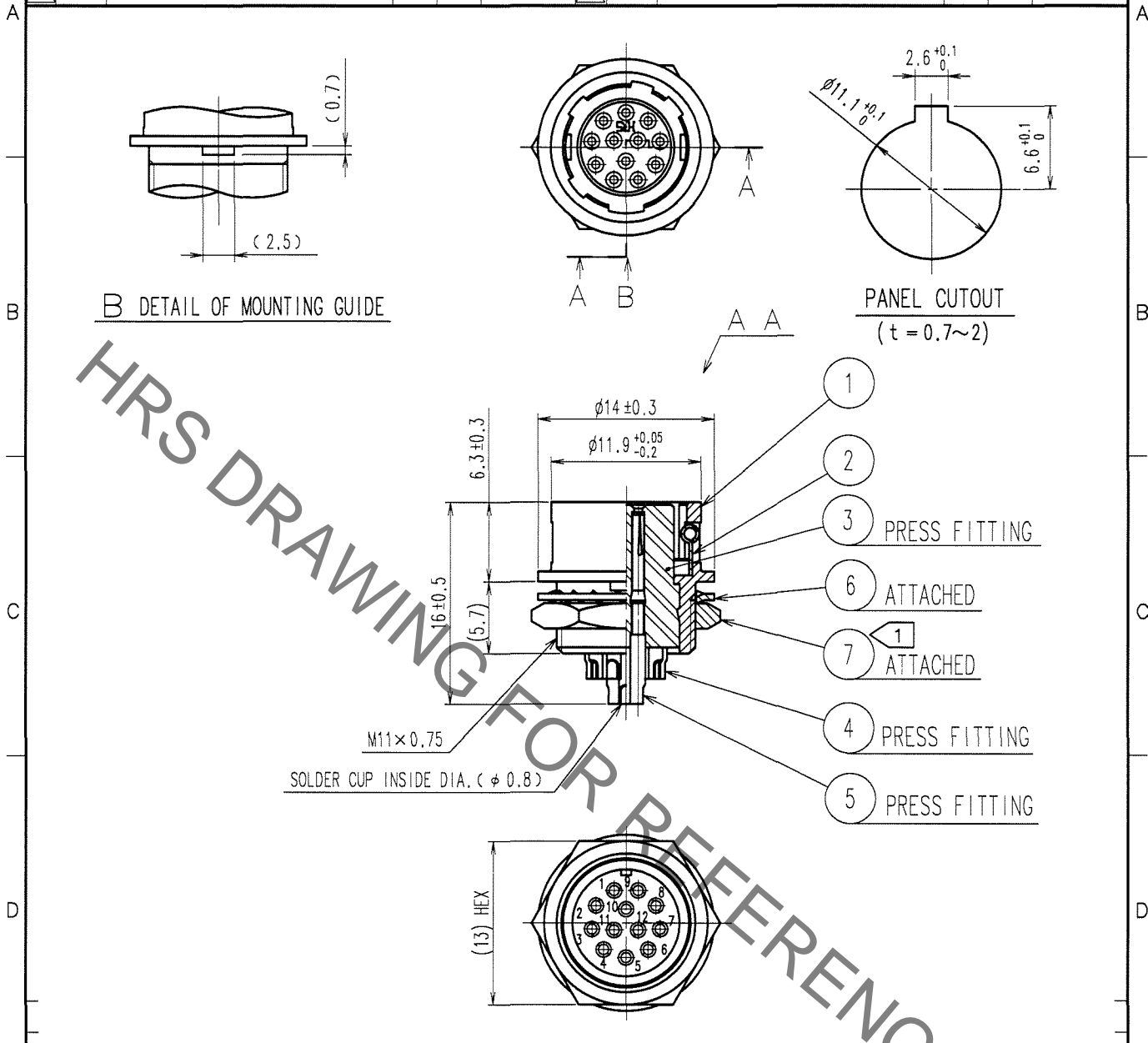

NOTE ① THE RECOMMENDED CLAMP TORQUE OF REF. NO. ⑦ TO BE 2 N·m.
LOCTITE 242, HENKEL JAPAN OR EQUIVALENT IS RECOMMENDED TO
PREVENT REF. NO. ⑦ FROM LOOSENING.

NO.	MATERIAL	FINISH, REMARKS	NO.	MATERIAL	FINISH, REMARKS
3	POLYAMIDE	(BLUE)	7	BRASS	NICKEL PLATING
2	STAINLESS STEEL		6	PHOSPHOR BRONZE	NICKEL PLATING
1	ZINC ALLOY	MATTE FINISH NICKEL PLATED	5	BERYLLIUM COPPER	GOLD PLATING 0.2μm min.
			4	BERYLLIUM COPPER	NICKEL UNDER PLATING 2μm min.

CODE NO. (OLD) CL	DRAWN S. Komatsu 05.11.30	DESIGNED D. Matsume 05.11.30	CHECKED E. Kuniti 05.11.30	APPROVED M. Sato 05.11.30	RELEASED
----------------------	---------------------------------	------------------------------------	----------------------------------	---------------------------------	----------

	DRAWING NO. EDC4-007770-73	PART NO. HR10-10R-12S(73)
		CODE NO. CL110-0035-0-73

TO
R