

Sep.1.2021 Copyright 2021 HIROSE ELECTRIC CO., LTD. All Rights Reserved.
In case of consideration for using Automotive equipment / device which demand high reliability, kindly contact our sales window correspondents.

| COUNT | DESCRIPTION OF REVISIONS | BY | CHKD | DATE | COUNT | DESCRIPTION OF REVISIONS | BY | CHKD | DATE |
|-------|--------------------------|-----|------|----------|-------|--------------------------|----|------|------|
| 1 | DIS-C-000409 | D.M | M.S | 06.12.19 | | | | | |

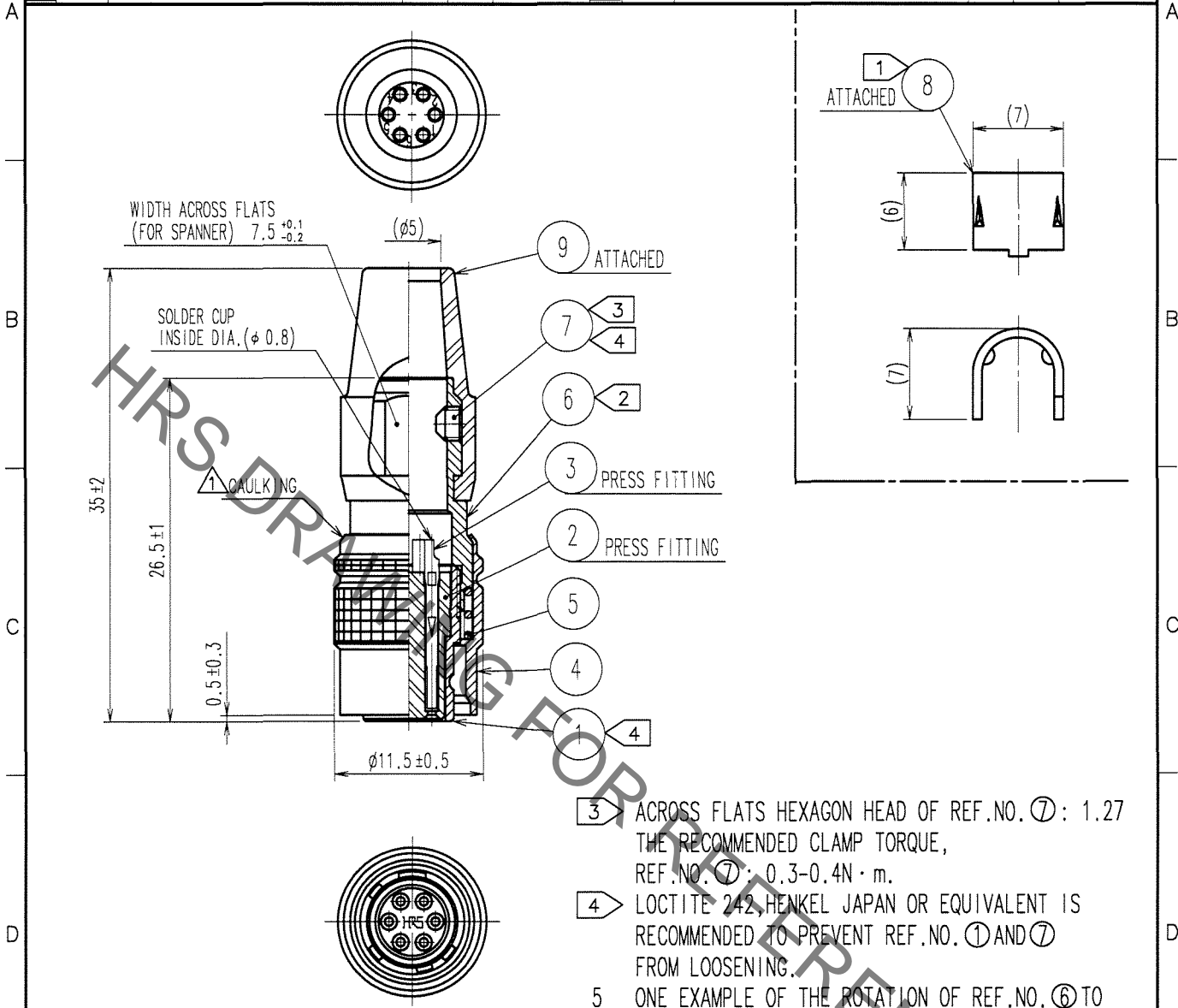

NOTE ① HAND CRIMPING TOOL, REF. NO. ⑧ :
HR10A-TC-02 (CL150-0041-2)
THE HOLE DIAMETER FOR CRIMPING: φ 5.3

② THE RECOMMENDED CLAMP TORQUE,
REF. NO. ⑥ : 1.5-2 N · m.

- ③ ACROSS FLATS HEXAGON HEAD OF REF. NO. ⑦ : 1.27 THE RECOMMENDED CLAMP TORQUE, REF. NO. ⑦ : 0.3-0.4N · m.
- ④ LOCTITE 242, HENKEL JAPAN OR EQUIVALENT IS RECOMMENDED TO PREVENT REF. NO. ① AND ⑦ FROM LOOSENING.
- 5 ONE EXAMPLE OF THE ROTATION OF REF. NO. ⑥ TO REF. NO. ① IS SHOWN.
- 6 THE CABLE STRENGTH, ROTATORY STRENGTH AND OTHER CHARACTERISTICS MAY DIFFER, DEPENDING ON THE CABLE STRUCTURE. PLEASE CONFIRM BEFORE THE USE.

| | | | | | |
|---|-----------------|--|---|----------------------------|--|
| 4 | BRASS | MATTE FINISH NICKEL PLATED | 9 | CHLOROPRENE RUBBER (BLACK) | |
| 3 | PHOSPHOR BRONZE | GOLD PLATING : 0.2 μ m min. NICKEL UNDER PLATING : 2 μ m min. | 8 | BRASS | |
| 2 | POLYAMIDE | (BLACK) UL94V-0 | 7 | STEEL | NICKEL PLATING HEXAGON SOCKET SET SCREW M2.6×0.45×2 |
| 1 | ZINC ALLOY | MATTE FINISH NICKEL PLATED | 6 | BRASS | NICKEL PLATING |
| | | | 5 | STEEL | NICKEL PLATING |

| NO. | MATERIAL | FINISH, REMARKS | NO. | MATERIAL | FINISH, REMARKS | | |
|----------------|----------|-----------------|--------|-----------|-----------------|----------|----------|
| CODE NO. (OLD) | CL | | DRAWN | DESIGNED | CHECKED | APPROVED | RELEASED |
| | | | M.SATO | D.MATSUNE | E.KUNII | M.SATO | |
| | | | 060801 | 060801 | 060801 | 060801 | |

| | | | | | |
|---------|----------------|-------------|----------------|----------|-----------------|
| TO R | SACLE 2 : 1 | DRAWING NO. | EDC4-020537-74 | PART NO. | HR10A-7P-6S(74) |
| | | UNITS | mm | CODE NO. | CL110-0304-0-74 |