

Sep.1.2021 Copyright 2021 HIROSE ELECTRIC CO., LTD. All Rights Reserved.
In case of consideration for using Automotive equipment / device which demand high reliability, kindly contact our sales window correspondents.

1			2			3			4					
COUNT	DESCRIPTION OF REVISIONS	BY	CHKD	DATE	COUNT	DESCRIPTION OF REVISIONS	BY	CHKD	DATE	COUNT	DESCRIPTION OF REVISIONS	BY	CHKD	DATE
△					△					△				
△					△					△				
△					△					△				

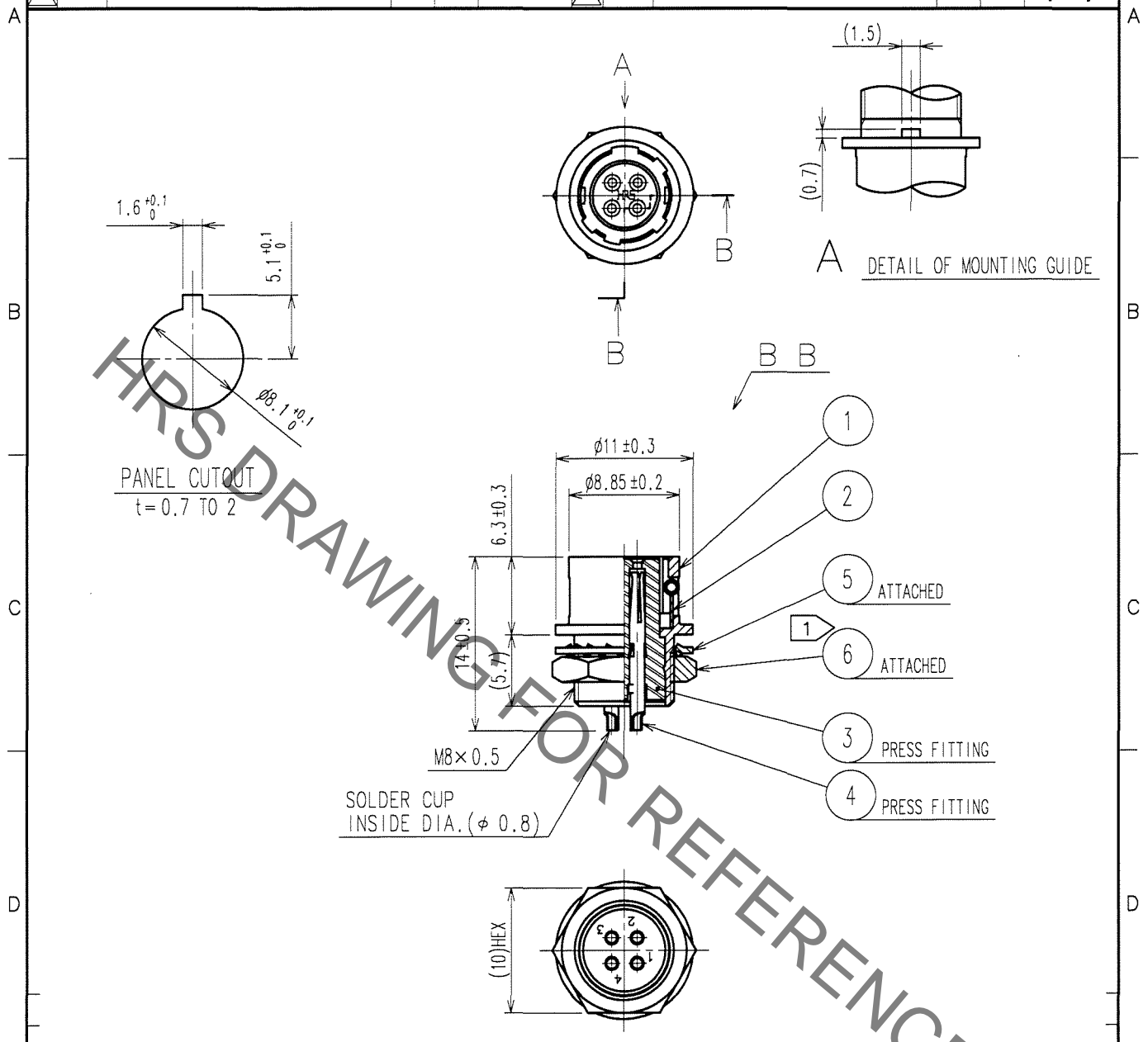

NOTE ① THE RECOMMENDED CLAMP TORQUE, REF. NO. ⑥ : 1.5N · m.
LOCTITE 242, HENKEL JAPAN OR EQUIVALENT IS RECOMMENDED TO PREVENT REF. NO. ⑥ FOR LOOSENING.

NO.	MATERIAL	FINISH, REMARKS	NO.	MATERIAL	FINISH, REMARKS
3	POLYAMIDE	(BLACK) UL94V-0	6	BRASS	NICKLE PLATING
2	STAINLESS STEEL		5	PHOSPHOR BRONZE	NICKEL PLATING
1	ZINC ALLOY	MATTE FINISH NICKEL PLATED	4	PHOSPHOR BRONZE	OVER PLATING: GOLD 0.2μ m min. UNDER PLATING: NICKEL 2μ m min.

CODE NO. (OLD) CL	DRAWN <i>M. Sato</i> 07.03.06	DESIGNED <i>J. Horii</i> 07.03.07	CHECKED <i>M. Sato</i> 07.03.07	APPROVED <i>M. Sato</i> 07.03.07	RELEASED
----------------------	-------------------------------------	---	---------------------------------------	--	----------

SCALE 2 : 1	DRAWING NO. EDC4-020538-74	PART NO. HR10A-7R-4S(74)
UNITS mm	HRS HIROSE ELECTRIC CO., LTD.	CODE NO. CL110-0305-3-74

TO
R