

Sep.1.2021 Copyright 2021 HIROSE ELECTRIC CO., LTD. All Rights Reserved.  
In case of consideration for using Automotive equipment / device which demand high reliability, kindly contact our sales window correspondents.

1					2					3					4				
COUNT	DESCRIPTION OF REVISIONS				BY	CHKD	DATE	COUNT	DESCRIPTION OF REVISIONS				BY	CHKD	DATE				
△								△											
△								△											
△								△											

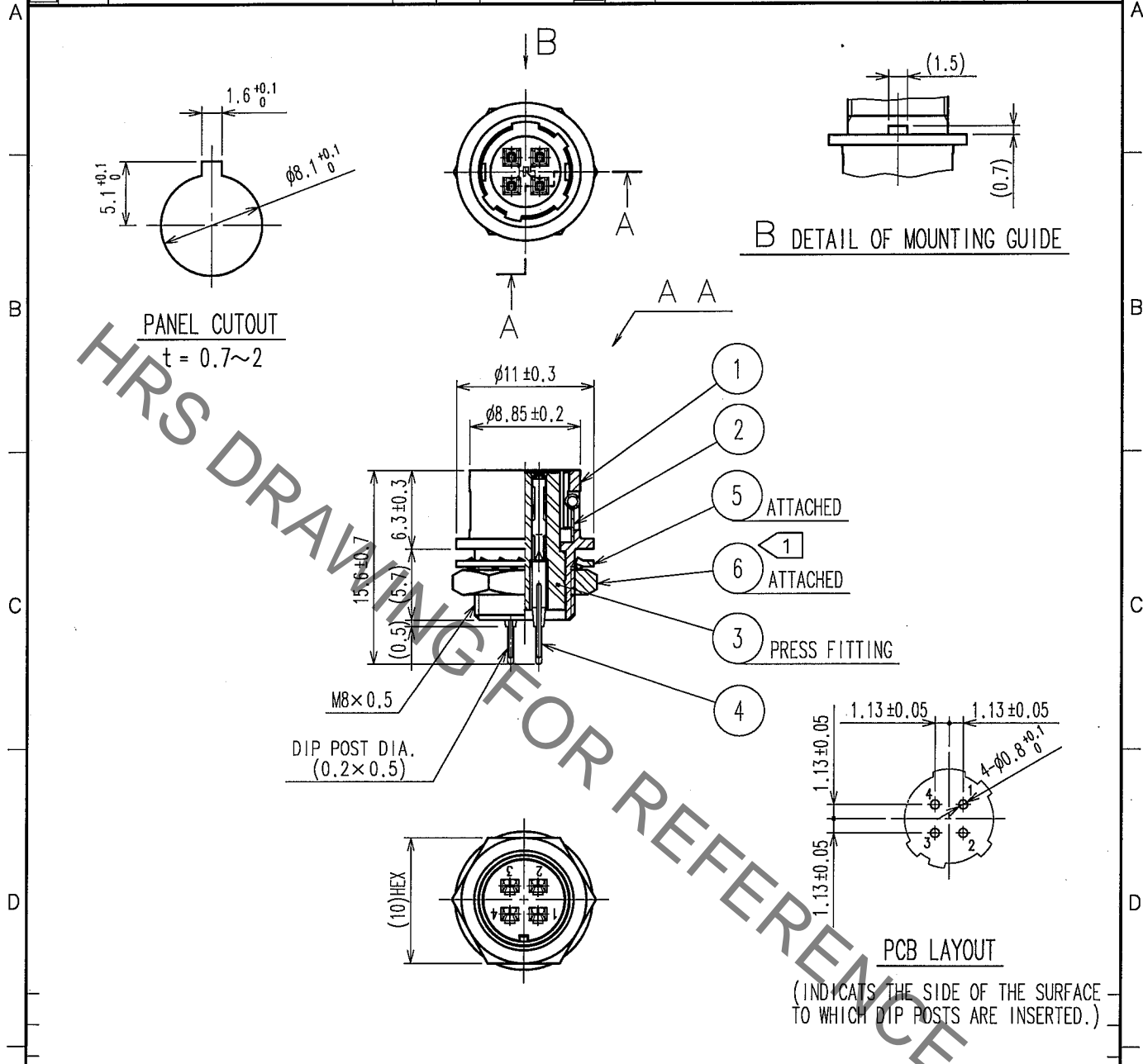

NOTE ① THE RECOMMENDED CLAMP TORQUE OF REF. NO. ⑥ TO BE 1.5 N · m.  
LOCTITE 242, HENKEL JAPAN OR EQUIVALENT IS RECOMMENDED TO PREVENT REF. NO. ⑥ FROM LOOSENING.  
② GOLD PLATING 0.2 μ m min.  
NICKEL UNDER PLATING 2 μ m min.

3	PBT	(BLACK) UL94V-0	6	BRASS	NICKEL PLATING
2	STAINLESS STEEL		5	PHOSPHOR BRONZE	NICKEL PLATING
1	ZINC ALLOY	MATTE FINISH NICKEL PLATED	4	PHOSPHOR BRONZE	②
NO.	MATERIAL	FINISH, REMARKS	NO.	MATERIAL	FINISH, REMARKS

CODE NO. (OLD)		DRAWN	DESIGNED	CHECKED	APPROVED	RELEASED
CL		<i>D. Matsume</i>	<i>D. Matsume</i>	<i>E. Kunita</i>	<i>M. Sato</i>	
		65.11.18	65.11.18	65.11.22	05.11.24	

DRAWING NO.		PART NO.	
EDC4-022527-74		HR10A-7R-4SB(74)	
UNITS		CODE NO.	
mm		CL110-0314-4-74	

TO
R