

Jan.1.2022 Copyright 2022 HIROSE ELECTRIC CO., LTD. All Rights Reserved. In case of consideration for using Automotive equipment / device which demand high reliability, kindly contact our sales window correspondents.

1		2			3			4		
COUNT	DESCRIPTION OF REVISIONS	BY	CHKD	DATE	COUNT	DESCRIPTION OF REVISIONS	BY	CHKD	DATE	
1	DIS-C-000409	D.M	M.S	06.12.19						

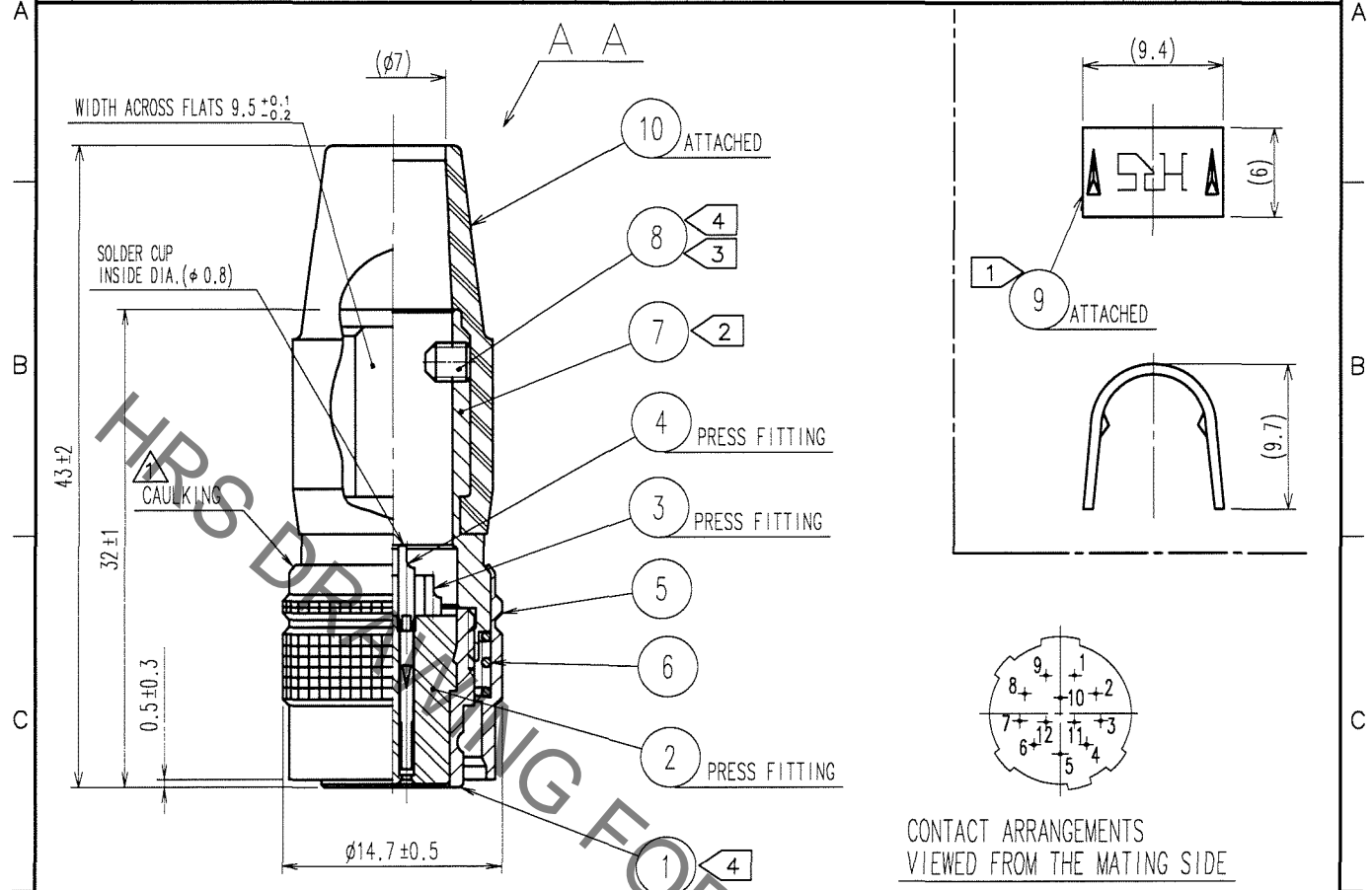

- NOTE ① HAND CRIMPING TOOL, REF. NO. ⑨: HR10A-TC-02, APPLY TO $\phi 7$.
- ② THE RECOMMENDED CLAMP TORQUE, REF. NO. ⑦: 2-2.5 N · m.
- ③ ACROSS FLATS HEXAGON HEAD OF REF. NO. ⑧: 1.27 THE RECOMMENDED CLAMP TORQUE, REF. NO. ⑧: 0.3-0.4N · m.
- ④ LOCTITE 242, HENKEL JAPAN OR EQUIVALENT IS RECOMMENDED TO PREVENT REF. NO. ① AND ⑧ FOR LOOSENING.
- ⑤ ONE EXAMPLE OF THE ROTATION OF REF. NO. ⑦ TO REF. NO. ① IS SHOWN.

5	BRASS	MATTE FINISH NICKEL PLATING	10	CR	(BLACK)
4	PHOSPHOR BRONZE	GOLD PLATING 0.2 μ m min.	9	BRASS	
3	PHOSPHOR BRONZE	NICKEL UNDER PLATING 2 μ m min.	8	STEEL	NICKEL PLATING JIS C 1177, HEXAGON SOCKET SET SCREW M2.6 \times 0.45 \times 3
2	POLYAMIDE	(BLACK) UL94V-0	7	BRASS	NICKEL PLATING
1	ZINC ALLOY	MATTE FINISH NICKEL PLATING	6	STEEL	NICKEL PLATING

NO.	MATERIAL	FINISH, REMARKS	NO.	MATERIAL	FINISH, REMARKS		
CODE NO. (OLD) CL			DRAWN	DESIGNED	CHECKED	APPROVED	RELEASED
			H.KISHI	H.KISHI	E.KUNII	M.SATO	
			'05.08.31	'05.08.31	'05.09.02	'05.09.02	
DRAWING NO. EDC4-020552-74			PART NO. HR10A-10P-12S(74)				
SACLE 2 : 1			CODE NO. CL110-0402-0-74				
UNITS mm			1/1				

TO
R