

Dec.1-2021 Copyright 2021 HIROSE ELECTRIC CO., LTD. All Rights Reserved.
 In case of consideration for using Automotive equipment / device which demand high reliability, kindly contact our sales window correspondents.

COUNT	DESCRIPTION OF REVISIONS	BY	CHKD	DATE	COUNT	DESCRIPTION OF REVISIONS	BY	CHKD	DATE
1	DIS-C-000585	T.K	E.K	07.07.27					

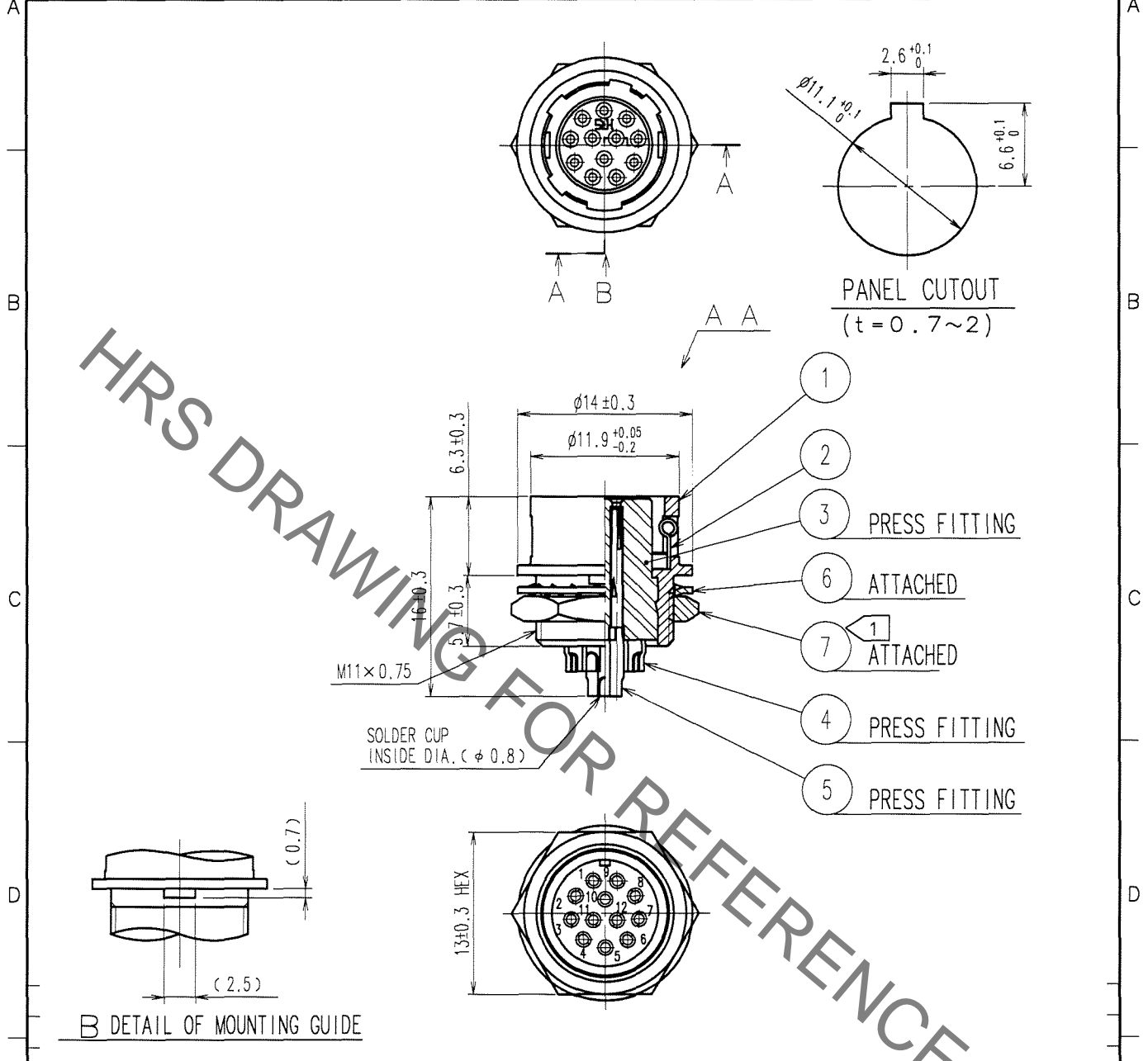

HRS DRAWING FOR REFERENCE

NOTE ① THE RECOMMENDED CLAMP TORQUE OF REF. NO. ⑦ TO BE 2 N · m.
 LOCTITE 242, HENKEL JAPAN OR EQUIVALENT IS RECOMMENDED TO
 PREVENT REF. NO. ⑦ FROM LOOSENING.

3	POLYAMIDE	(BLACK) UL94V-0	7	BRASS	NICKEL PLATING
2	STAINLESS STEEL		6	PHOSPHOR BRONZE	NICKEL PLATING
1	ZINC ALLOY	MATTE FINISH NICKEL PLATED	5	PHOSPHOR BRONZE	OVER PLATING:GOLD 0.2μ m min. UNDER PLATING:2μ m min.
NO.	MATERIAL	FINISH, REMARKS	NO.	MATERIAL	FINISH, REMARKS

CODE NO. (OLD)	CL	DRAWN	DESIGNED	CHECKED	APPROVED	RELEASED
		M.SATO	TO.HORII	E.KUNII	M.SATO	
		'07 03 07	'07 03 07	'07 03 08	'07 03 08	

	DRAWING NO.	PART NO.
	EDC4-010387-72	HR10A-10R-12S(72)
SCALE	CODE NO.	
2 : 1	CL110-0403-2-72	
UNITS	HIROSE ELECTRIC CO., LTD.	
mm		

TO
R