

May.1.2022 Copyright 2022 HIROSE ELECTRIC CO., LTD. All Rights Reserved.  
 In case of consideration for using Automotive equipment / device which demand high reliability, kindly contact our sales window correspondents.

COUNT	DESCRIPTION OF REVISIONS	BY	CHKD	DATE	COUNT	DESCRIPTION OF REVISIONS	BY	CHKD	DATE
1	DIS-C-000585	T.K	E.K	07.07.27					

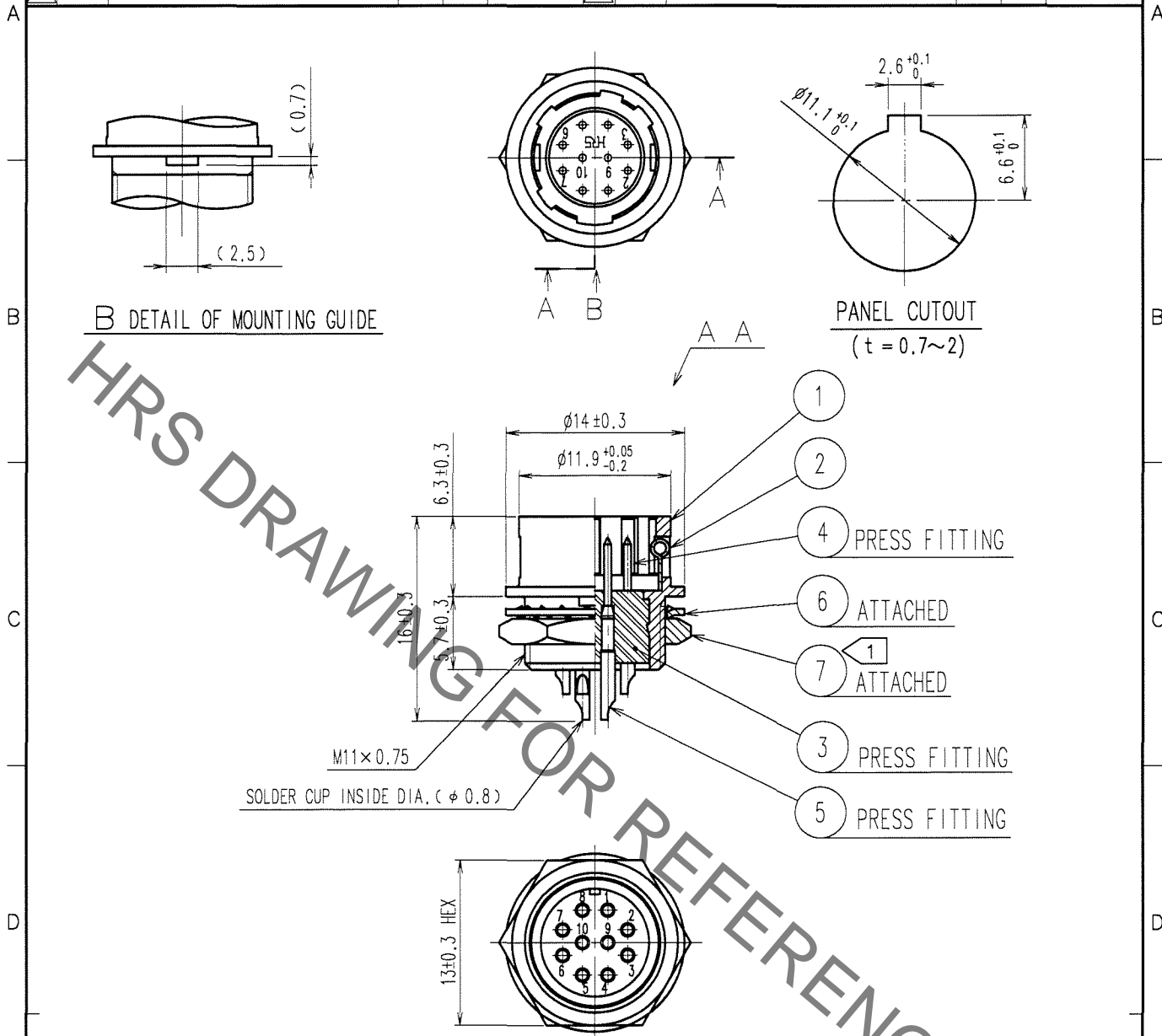

NOTE ① THE RECOMMENDED CLAMP TORQUE OF REF. NO. ⑦ TO BE 2 N · m.  
 LOCTITE 242, HENKEL JAPAN OR EQUIVALENT IS RECOMMENDED TO  
 PREVENT REF. NO. ⑦ FROM LOOSENING.

NO.	MATERIAL	FINISH, REMARKS	NO.	MATERIAL	FINISH, REMARKS
3	POLYAMIDE	(BLACK) UL94V-0	7	BRASS	NICKEL PLATING
2	STAINLESS STEEL		6	PHOSPHOR BRONZE	NICKEL PLATING
1	ZINC ALLOY	MATTE FINISH NICKEL PLATED	5	BRASS	SILVER PLATING 2μ m min.
			4	BRASS	

CODE NO. (OLD)	CL	DRAWN	DESIGNED	CHECKED	APPROVED	RELEASED
		D.MATSUNE	D.MATSUNE	E.KUNII	M.SATO	
		'05 10 01	'05 10 01	'05 10 03	'05 10 14	

DRAWING NO.	PART NO.
EDC4-021369-73	HR10A-10R-10P(73)
UNITS	CODE NO.
mm	CL110-0410-8-73

TO
R