

Aug.1.2021 Copyright 2021 HIROSE ELECTRIC CO., LTD. All Rights Reserved.
 Case of consideration for using Automotive equipment / device which demand high reliability, kindly contact our sales window correspondents.

1					2					3					4				
COUNT	DESCRIPTION OF REVISIONS				BY	CHKD	DATE	COUNT	DESCRIPTION OF REVISIONS				BY	CHKD	DATE				
△								△											
△								△											
△								△											

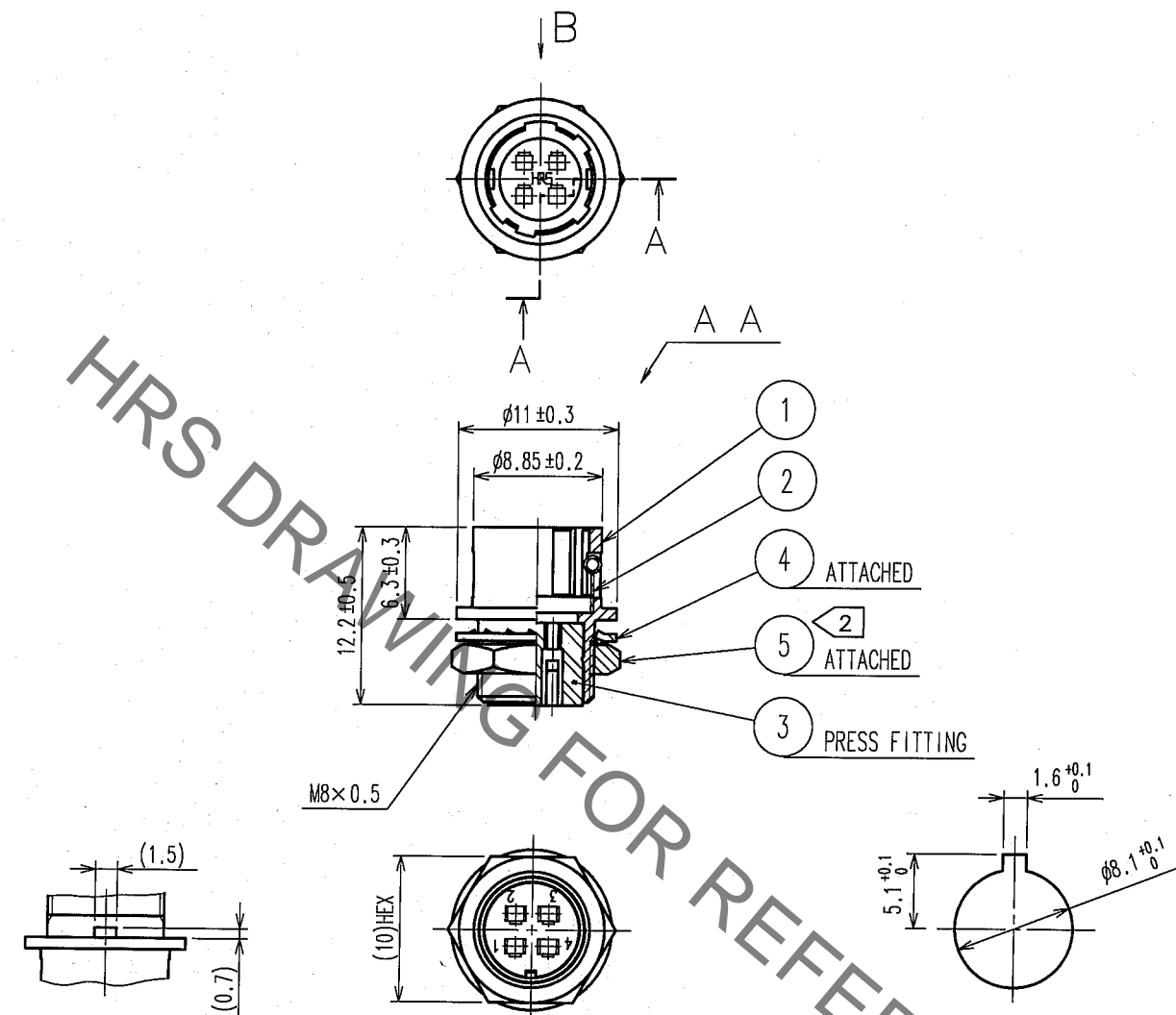

B DETAIL OF MOUNTING GUIDE

NOTE 1 APPLICABLE CONTACT : HR10-PC-212
 APPLICABLE WIRE : AWG#26~30 (INSULATOR OUTER DIA. OF ϕ 1 OR LESS)
 APPLICABLE TOOL, EXTRACTPR : RP6-SC-TP
 ② THE RECOMMENDED CLAMP TORQUE OF REF.NO. ⑤ : 1.5N · m .
 LOCTITE 242, HENKEL JAPAN OR EQUIVALENT IS RECOMMENDED TO PREVENT
 REF. NO. ⑤ FROM LOOSENING.

NO.	MATERIAL	FINISH, REMARKS	NO.	MATERIAL	FINISH, REMARKS
3	PBT	(BLACK) UL94V-0			
2	STAINLESS STEEL		5	BRASS	NICKEL PLATING
1	ZINC ALLOY	MATTE FINISH NICKEL PLATED	4	PHOSPHOR BRONZE	NICKEL PLATING

CODE NO. (OLD)	CL	DRAWN	DESIGNED	CHECKED	APPROVED	RELEASED
		H.Kishi	H.Kishi	E. Kumai	M. Sato	
		'05.08.29	'05.08.29	05.08.30	05.08.30	

SCALE	2 : 1	DRAWING NO.	EDC4-025175-73	PART NO.	HR10A-7R-4PC(73)
UNITS	mm	CODE NO.	CL110-0505-2-73		1/1

