

Dec.1.2021 Copyright 2021 HIROSE ELECTRIC CO., LTD. All Rights Reserved.
 In case of consideration for using Automotive equipment / device which demand high reliability, kindly contact our sales window correspondents.

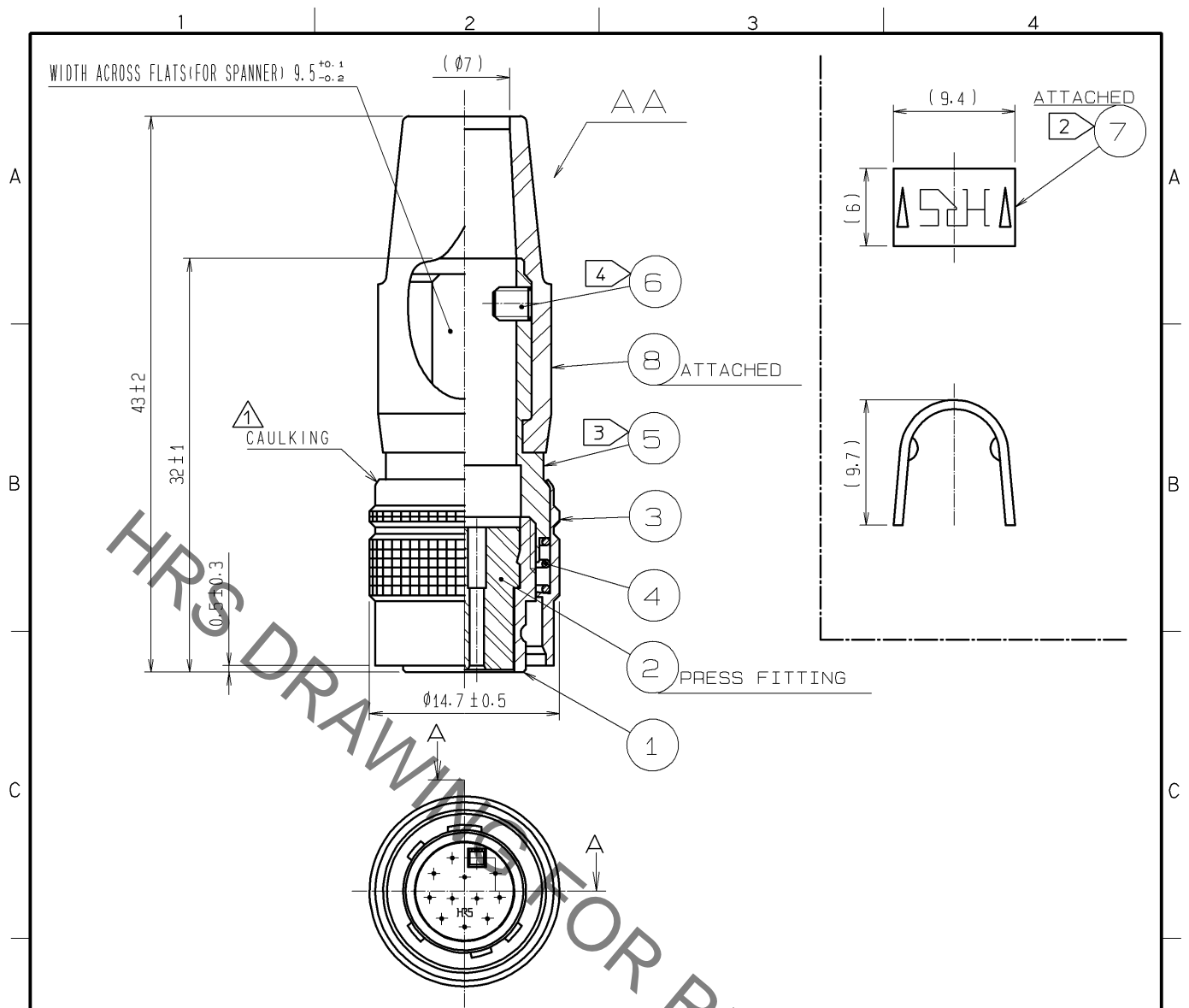

NOTE 1. APPLICABLE CRIMP CONTACT :HR12-SC-212
 (APPLICABLE CABLE:26-30AWG. (JACKET DIAMETER φ1 MAX))
 APPLICABLE CRIMP CONTACT EXTRACTION TOOL:HR12-SC-TP

② HAND CRIMPING TOOL. REF. NO. ⑦ :HR10A-TC-02

③ THE RECOMMENDED CLAMP TORQUE . REF. NO. ⑤ :2 TO 2.5N·m.
 LOCTITE 242, LOCTITE JAPAN OR EQUIVALENT IS RECOMMENDED TO PREVENT REF. NO. ⑤ FOR LOOSEING.

④ ACROSS FLATS OF HEXAGON HOLE OF REF. NO. ⑥ TO BE 1.27.
 APPLICABLE DRIVER:PB205/1.27.
 THE RECOMMENDED CLAMP TORQUE. REF. NO. ⑥ :0.3 TO 0.4N·m.
 LOCTITE242, HENKEL JAPAN OR EQUIVALENT IS RECOMMENDED TO PREVENT REF. NO. ⑥ FOR LOOSENING.

5 ROTATION EXAMPLES OF REF. NO. ① AND ⑤ ARE SHOWN.

6 THE CABLE PULL AND TWISTING STRENGTH AND OTHER CHARACTERISTICS MAY DIFFER,
 DEPENDING ON THE CABLE STRUCTURE.
 PLEASE CONFIRM BEFORE THE USE.

4	STEEL	NICKEL PLATING	8	CHLOROPRENE RUBBER	(BLACK)
3	BRASS	MATTE FINISH NICKEL PLATED	7	BRASS	
2	POLYBUTYLENE TEREPHTHALATE	(BLACK) UL94V-0	6	STEEL	NICKEL PLATING M2.6X0.45X3
1	ZINC ALLOY	MATTE FINISH NICKEL PLATED	5	BRASS	NICKEL PLATING
NO.	MATERIAL	FINISH, REMARKS	NO.	MATERIAL	FINISH, REMARKS

UNITS mm		SCALE 2 : 1	COUNT 1	DESCRIPTION OF REVISIONS DIS-C-000409	DESIGNED DS.MATSUNE	CHECKED MO.SATOH	DATE 06.12.19
HIROSE ELECTRIC CO., LTD. APPROVED : MO.SATOH 06.10.27 CHECKED : EJ.KUNII 06.10.27 DESIGNED : TP.KOMATSU 06.10.27 DRAWN : MK.SATO 06.10.27				DRAWING NO. EDC4-025180-73 PART NO. HR10A-10P-12SC(73) CODE NO. CL110-0604-4-73			