

Nov.1.2021 Copyright 2021 HIROSE ELECTRIC CO., LTD. All Rights Reserved.
 In case of consideration for using Automotive equipment / device which demand high reliability, kindly contact our sales window correspondents.

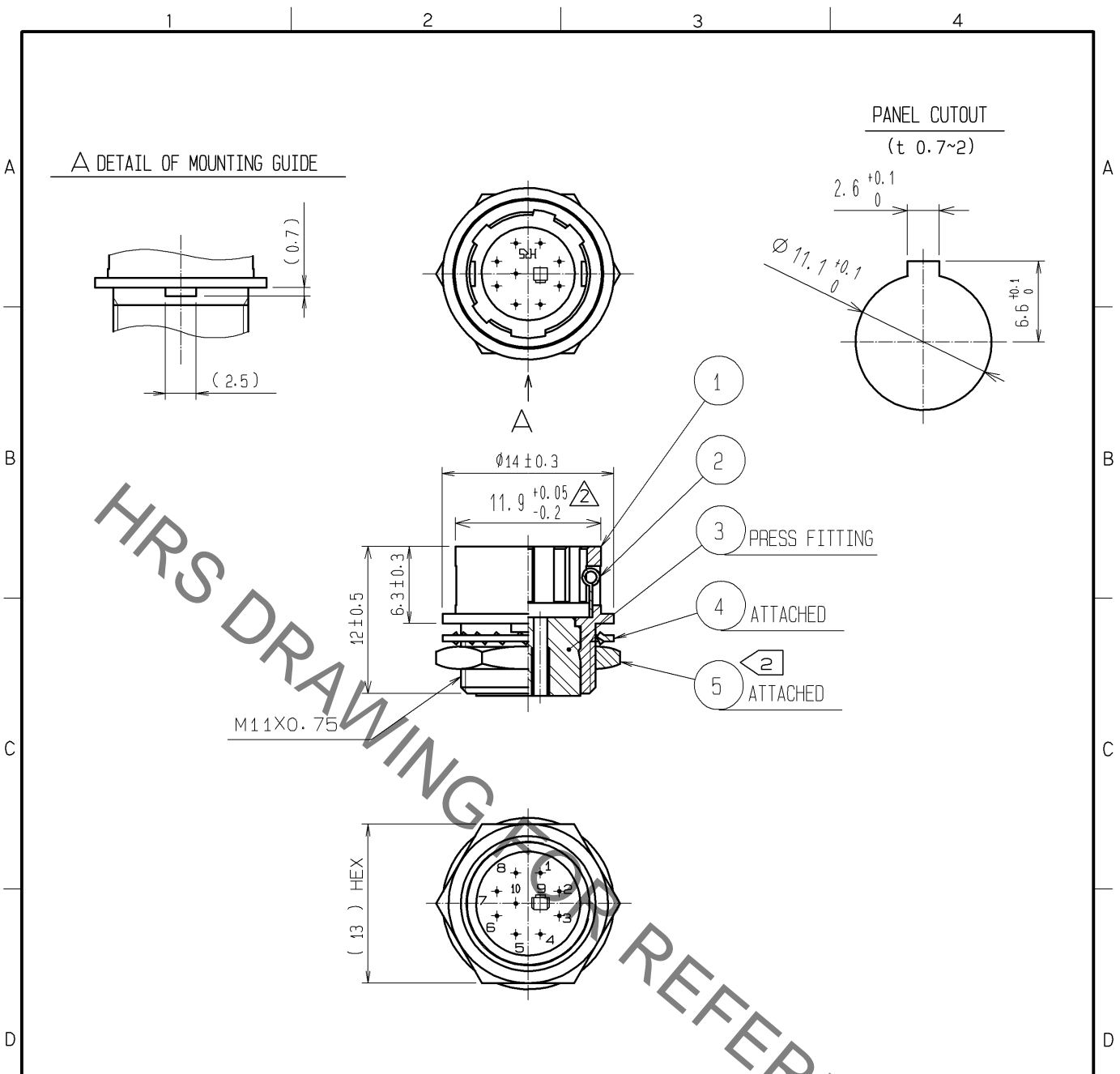

NOTES 1 APPLICABLE CRIMP CONTACT:HR10-PC-212(CL110-0514-3)
 APPLICABLE WIRE:AWG#26 TO #30(COVERED WIRE MAX. OUTSIDE DIA.Ø1)
 APPLICABLE CONTACT REMOVAL TOOL (EXTRACTION TOOL):RP6-SC-TP(CL150-0039-0)
 2 THE RECOMMENDED CLAMP TORQUE OF REF. NO. 5 TO BE 2 N·m.
 LOCTITE 243, HENKEL JAPAN OR EQUIVALENT IS RECOMMENDED TO PREVENT REF. NO. 5 FROM LOOSENING.

NO.	MATERIAL	FINISH, REMARKS	NO.	MATERIAL	FINISH, REMARKS
3	POLYBUTYLENE TEREPHTHALATE	(BLACK) UL94V-0	5	BRASS 1	NICKEL PLATING
2	STAINLESS STEEL		4	PHOSPHOR BRONZE	NICKEL PLATING
1	ZINC ALLOY	MATTE FINISH NICKEL PLATED			

UNITS	SCALE	COUNT	DESCRIPTION OF REVISIONS	DESIGNED	CHECKED	DATE
mm	2 : 1	2	DIS-C-003736	HR. SATO	HY. KISHI	14.11.25

HIROSE ELECTRIC CO., LTD.	APPROVED :MO. SATOH	07.03.13	DRAWING NO.	EDC4-026325-71
	CHECKED :EJ. KUNII	07.03.12	PART NO.	HR10A-10R-10PC(71)
	DESIGNED :TO. HORII	07.03.09	CODE NO.	CL110-0605-7-71
	DRAWN :MK. SATO	07.03.09		