

Jan.1.2022 Copyright 2022 HIROSE ELECTRIC CO., LTD. All Rights Reserved.
In case of consideration for using Automotive equipment / device which demand high reliability, kindly contact our sales window correspondents.

COUNT	DESCRIPTION OF REVISIONS	BY	CHKD	DATE	COUNT	DESCRIPTION OF REVISIONS	BY	CHKD	DATE
1	DIS-C-000409	D.M	M.S	06.12.19					

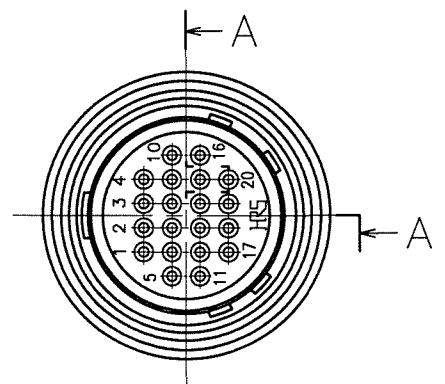
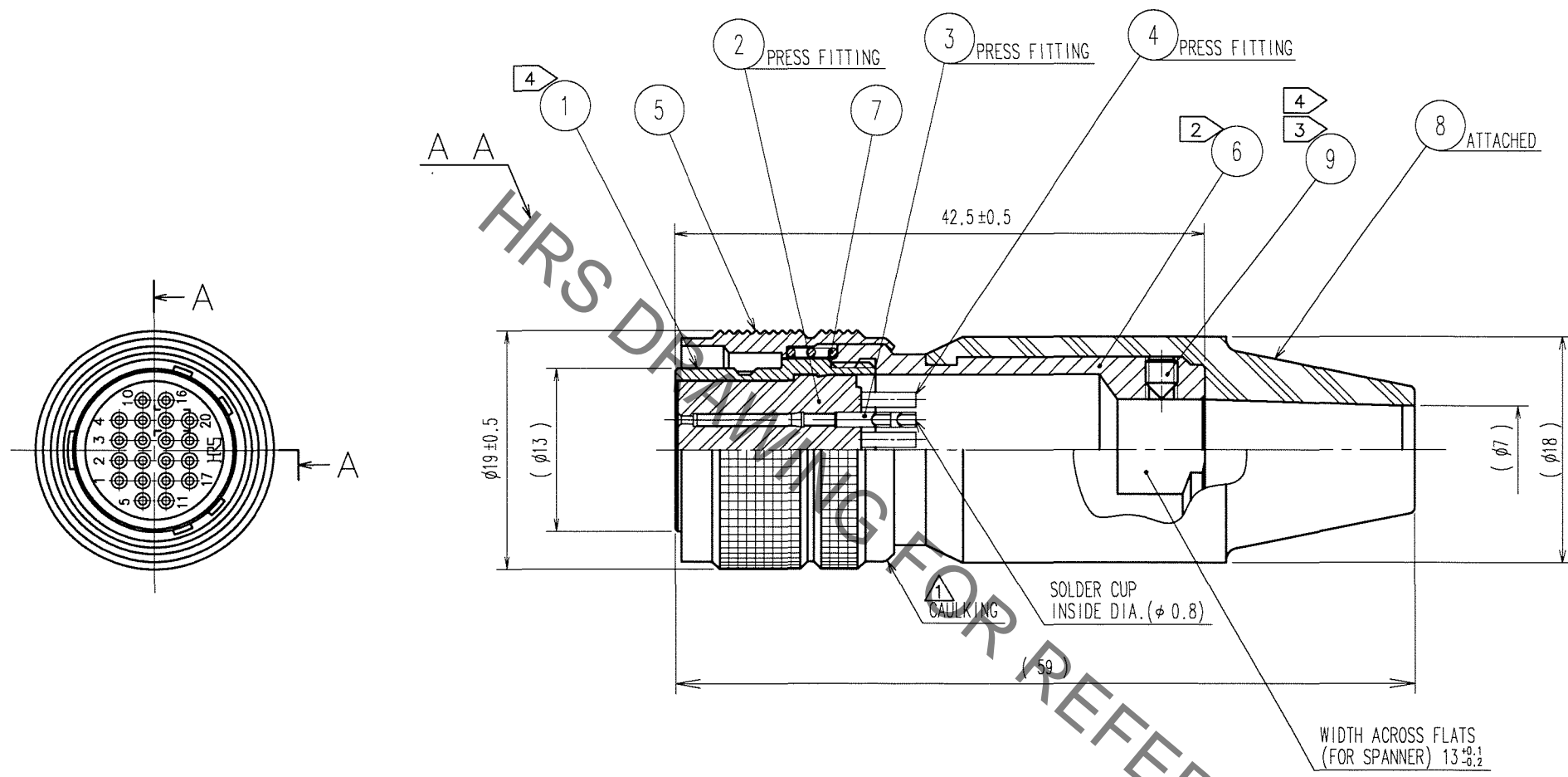

- NOTE:
- ① HAND CRIMPING TOOL, REF. NO. ⑩ : HR10A-TC-02 (CL150-0041-2)
THE HOLE DIAMETER FOR CRIMPING : φ 7.0
 - ② THE RECOMMENDED CLAMP TORQUE, REF. NO. ⑥ : 2-2.5N · m.
 - ③ ACROSS FLATS HEXAGON HEAD OF REF. NO. ⑨ : 1.27
THE RECOMMENDED CLAMP TORQUE, REF. NO. ⑨ : 0.3-0.4N · m.
REF. NO. ⑨ SHALL BE TIGHTENED WITH ITS TIPS PRESSED INTO THE DIMPLE AREA OF REF. NO. ⑩.
 - ④ LOCTITE 242, HENKEL JAPAN OR EQUIVALENT IS RECOMMENDED TO PREVENT REF. NO. ① AND ⑨ FROM LOOSENING.
 - 5 ONE EXAMPLE OF THE ROTATION OF REF. NO. ⑥ TO REF. NO. ① IS SHOWN.

5	BRASS	MATTE FINISH NICKEL PLATED	10	BRASS	
4	BERYLLIUM COPPER	SILVER PLATING 2μm min.	9	STEEL	NICKEL PLATING JIS B 1177 HEXAGON SOCKET SET SCREW M2.6X0.45X3
3			8	CR	(BLACK)
2	POLYAMIDE	(BLACK) UL94V-0	7	STEEL	NICKEL PLATING
1	ZINC ALLOY	MATTE FINISH NICKEL PLATED	6	BRASS	NICKEL PLATING
NO.	MATERIAL	FINISH, REMARKS	NO.	MATERIAL	FINISH, REMARKS
CODE NO. (OLD)			DRAWN	DESIGNED	CHECKED
			D. MATSUNE	D. MATSUNE	E. KUNII
			'05.10.01	'05.10.01	'05.10.03
			APPROVED	RELEASED	
			M. SATO		
			'05.10.14		
DRAWING NO.		PART NO.			
EDC3-046520-73		HR10A-13P-20S(73)			
SCALE		CODE NO.			
2 : 1		CL110-0716-8-73			
UNITS		mm			
mm		HRS HIROSE ELECTRIC CO., LTD.			

TO
R