

Dec.1.2021 Copyright 2021 HIROSE ELECTRIC CO., LTD. All Rights Reserved.  
 In case of consideration for using Automotive equipment / device which demand high reliability, kindly contact our sales window correspondents.

1		2			3			4		
COUNT	DESCRIPTION OF REVISIONS	BY	CHKD	DATE	COUNT	DESCRIPTION OF REVISIONS	BY	CHKD	DATE	
△					△					
△					△					
△					△					

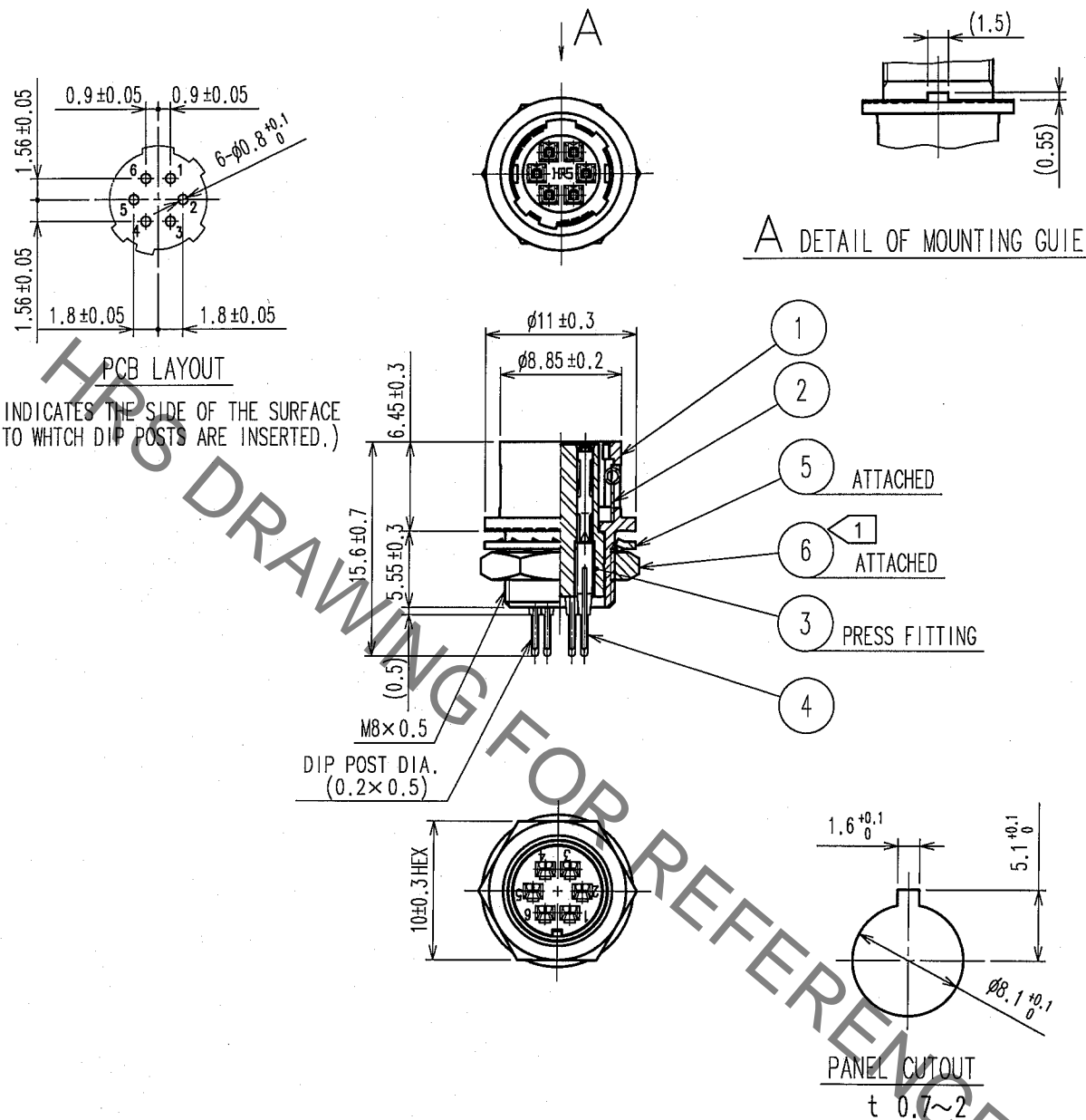

NOTE ① THE RECOMMENDED CLAMP TORQUE OF REF.NO. ⑥ : 1.5N · m.  
 LOCTITE 242, HENKEL JAPAN OR EQUIVALENT IS RECOMMENDED TO PREVENT  
 REF. NO. ⑥ FROM LOOSENING.

3	PBT	(BLACK) UL94V-0	6	BRASS	NICKEL PLATING
2	STAINLESS STEEL		5	PHOSPHOR BRONZE	NICKEL PLATING
1	ZINC ALLOY	MATTE FINISH NICKEL PLATED	4	PHOSPHOR BRONZE	SILVER PLATING 2 μm min.
NO.	MATERIAL	FINISH, REMARKS	NO.	MATERIAL	FINISH, REMARKS

CODE NO. (OLD)	DRAWN	DESIGNED	CHECKED	APPROVED	RELEASED
CL	H.Kishi 05.08.31	H.Kishi 05.08.31	E. Kurui 05.09.02	M. Sato 05.09.02	

 SCALE 2 : 1 UNITS mm	DRAWING NO. EDC4-042752-73 	PART NO. HR10G-7R-6SB(73) CODE NO. CL110-1805-1-73	1/1
-----------------------------------	-----------------------------------	---	-----