

Apr.1.2021 Copyright 2021 HIROSE ELECTRIC CO., LTD. All Rights Reserved.
 In case of consideration for using Automotive equipment / device which demand high reliability, kindly contact our sales window correspondents.

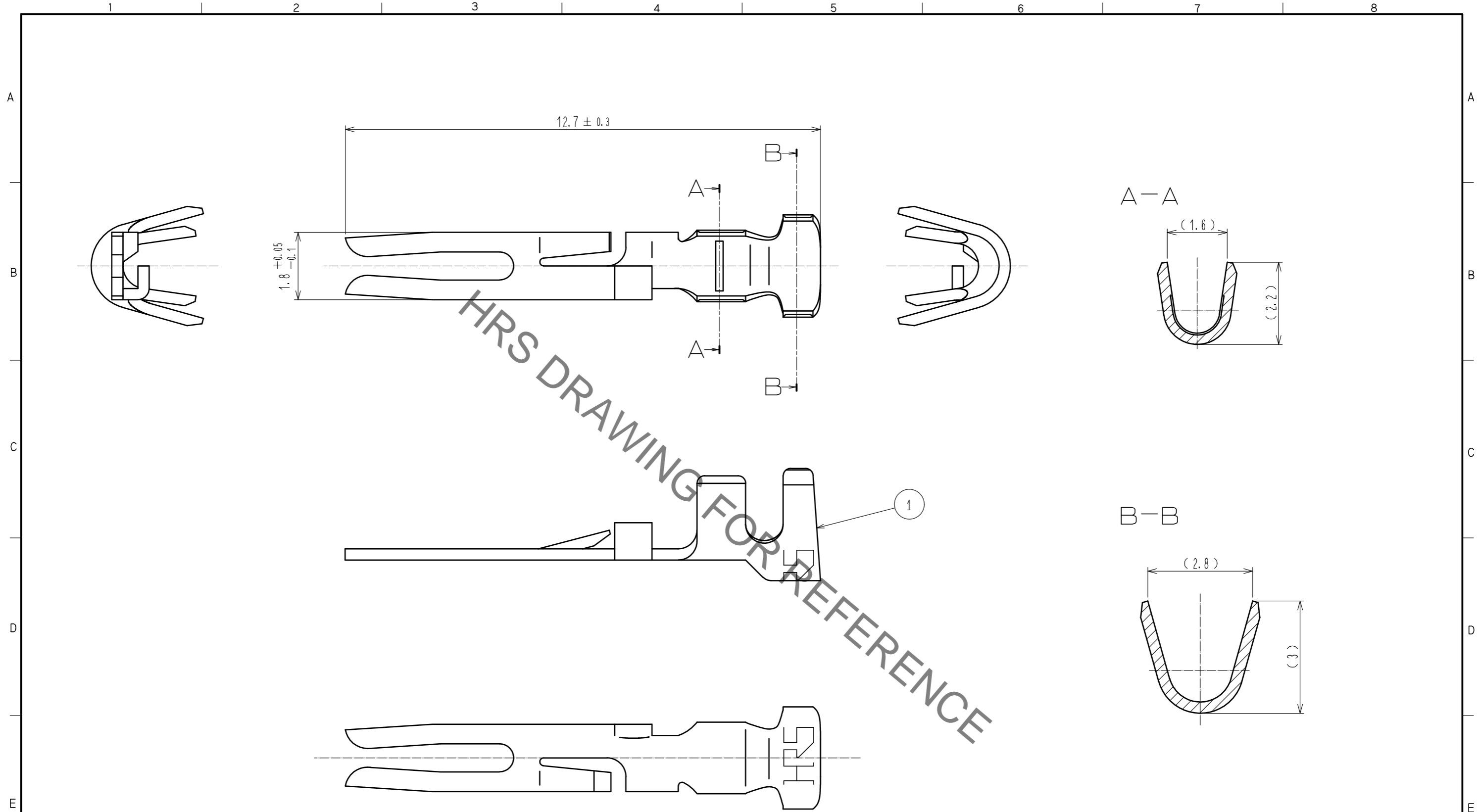

NOTES 1 THIS PRODUCT IS APPLY TO THE WIRE AWG#18 TO #22(WIRE JACKET DIAMETER ϕ 1.8 MAX)
 2 HAND CRIMPING TOOL:HT-102/RP34L-SC1-212(CL150-0210-8).
 ③ CONTACT PORTION:NICKEL UNDER PLATING $1\mu\text{m}$ min. PALLADIUM PLATING $1\mu\text{m}$ min.
 OTHER:NICKEL PLATING $1\mu\text{m}$ min.

1	PHOSPHOR BRONZE	③ (PER PACK:100 PCS.)				
NO.	MATERIAL	FINISH . REMARKS	NO.	MATERIAL	FINISH . REMARKS	
UNITS mm			SCALE 10:1		DESCRIPTION OF REVISIONS	DESIGNED
						CHECKED
						DATE
HRS	HIROSE ELECTRIC CO., LTD.	APPROVED :HY. KOBAYASHI	15.10.22	DRAWING NO.	EDC-113159-01-00	
		CHECKED :HY. KOBAYASHI	15.10.22	PART NO.	RP34L-SC1-112(01)	
		DESIGNED :DS. MATSUNE	15.10.22	CODE NO.	CL113-5179-7-01	
		DRAWN :DS. MATSUNE	15.10.22			