

Jun.1.2022 Copyright 2022 HIROSE ELECTRIC CO., LTD. All Rights Reserved.
In case of consideration for using Automotive equipment / device which demand high reliability, kindly contact our sales window correspondents.

Fig. 2(1:1)

A-A

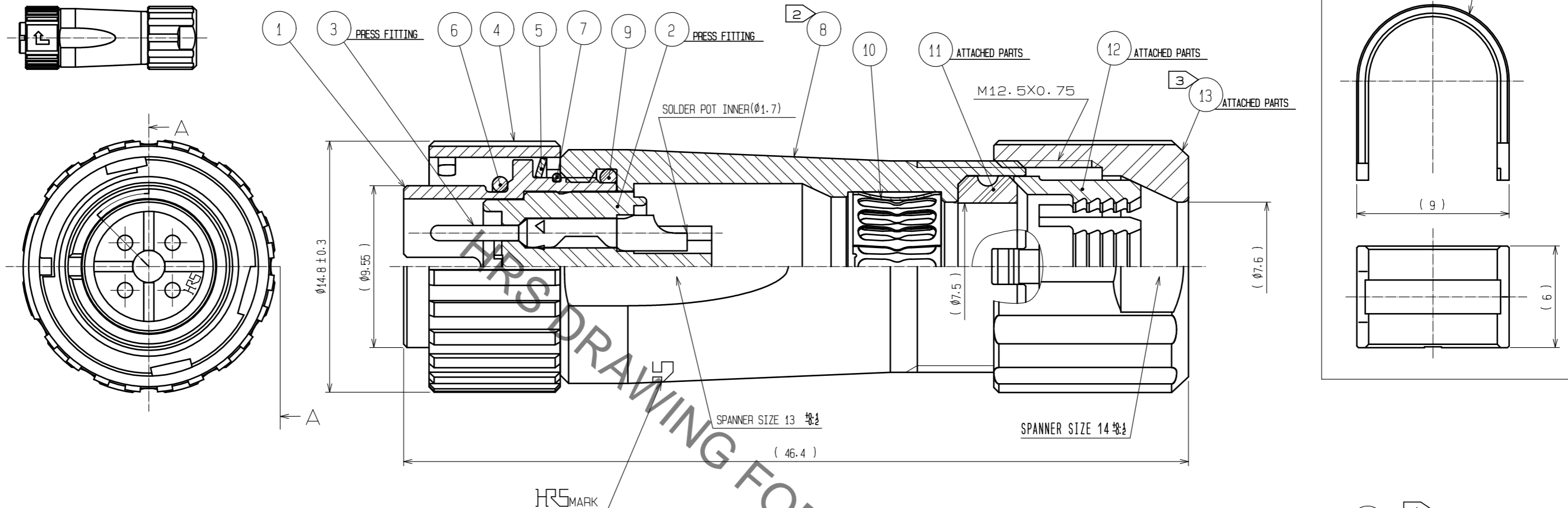
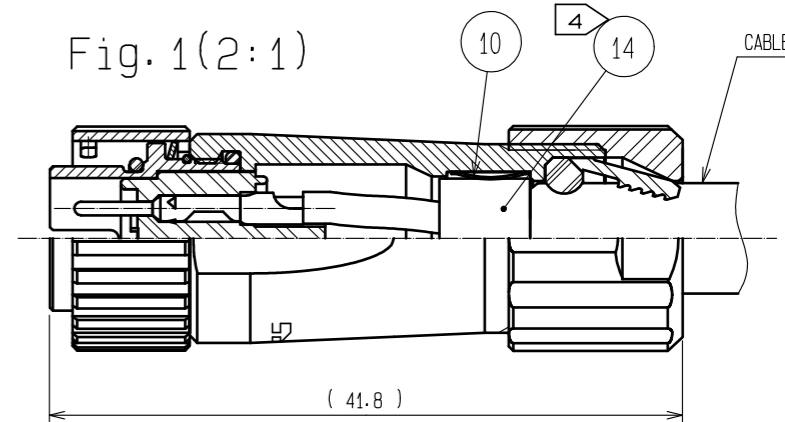

Fig. 1(2:1)



- NOTES
- 1 PLATING(REF.NO.③)
CONTACT AREA : GOLD 0.2μm min
OTHERS : GOLD AND NICKEL
UNDER PLATING : NICKEL 2μm min
 - 2 THE RECOMMENDED CLAMP TORQUE OF REF.NO.⑧ TO BE 1 TO 1.5N·m.
THREAD LOCKER TO THE THREADED PORTION OF REF.NO.① IS RECOMMENDED TO PREVENT REF.NO.⑧ FROM LOOSING.
RECOMMENDED THREAD LOCKER : LOCTITE 263, HENKEL JAPAN LTD.
 - 3 THE RECOMMENDED CLAMP TORQUE OF REF.NO.⑬ TO BE 0.8 TO 1N·m.
THREAD LOCKER AND LOCK PRIMER TO THE THREADED PORTION M12.5X0.75 OF REF.NO.⑧ IS RECOMMENDED TO PREVENT REF.NO.⑬ FROM LOOSING.
RECOMMENDED THREAD LOCKER AND LOCK PRIMER : LOCTITE 263, LOCK PRIMER 7649, HENKEL JAPAN LTD.
 - 4 FASTEN REF.NO.⑭ TO THE CABLE WITH THE CABLE CRIMPING TOOL.
AND MAKE REF.NO.⑭ CONTACT WITH REF.NO.⑩ (REFER TO Fig.1).
REFER TO THE TECHNICAL SPECIFICATION ETAD-C0099 FOR DETAILS.
APPLICABLE CABLE CRIMPING TOOL : LF-TC-01 (CL150-0234-6)
 - 5 APPLICABLE CABLE ASSEMBLY FIXTURE : LF10BP-T01 (CL150-0235-9)
CABLE ASSEMBLY FIXTURE IS USED AS A RECEPTACLE STAND OF EXTRACT AND THE PART NUMBER ① OF AN ASSEMBLY.
 - 6 Fig.2 SHOWS THE APPEARANCE AFTER ASSEMBLY.
 - 7 ROTATION EXAMPLES OF REF.④, ⑧ AND ⑬ TO ① ARE SHOWN.
 - 8 CABLE PULL FORCE, TWISTING STRENGTH, WATER TIGHTNESS AND OTHER CHARACTERISTICS MAY DIFFER DEPENDING ON CABLE SPECIFICATIONS AND STRUCTURE.
PLEASE EVALUATE UNDER THE ACTUAL CONDITIONS PRIOR TO USE.

7	STAINLESS STEEL		14	BRASS	NICKEL PLATING
6	CHLOROPRENE RUBBER	(BLACK)	13	PPS	(NATURAL·BROWN) UL94V-0
5	STAINLESS STEEL		12	POLYAMIDE	(NATURAL·MILKY WHITE) UL94V-0
4	ZINC ALLOY	NICKEL PLATING	11	CHLOROPRENE RUBBER	(BLACK)
3	COPPER ALLOY	①	10	PHOSPHOR BRONZE	NICKEL PLATING
2	PPS	(BLACK) UL94V-0	9	CHLOROPRENE RUBBER	(BLACK)
1	ZINC ALLOY	NICKEL PLATING	8	ZINC ALLOY	NICKEL PLATING
NO.	MATERIAL	FINISH . REMARKS	NO.	MATERIAL	FINISH . REMARKS
UNITS mm		SCALE 4 : 1	COUNT		DESCRIPTION OF REVISIONS
DESIGNED		CHECKED		DATE	
APPROVED : HY. KOBAYASHI			18.02.21		
CHECKED : HY. KOBAYASHI			18.02.21		
DESIGNED : TY. SUZUKI			18.02.21		
DRAWN : HM. SAITO			18.02.21		
DRAWING NO.		EDC-114241-31-00			
PART NO.		LF10WBP-4P(31)			
CODE NO.		CL136-0006-5-31			
HRS		HIROSE ELECTRIC CO., LTD.		1/1	