

Aug.1.2021 Copyright 2021 HIROSE ELECTRIC CO., LTD. All Rights Reserved.  
In case of consideration for using Automotive equipment / device which demand high reliability, kindly contact our sales window correspondents.

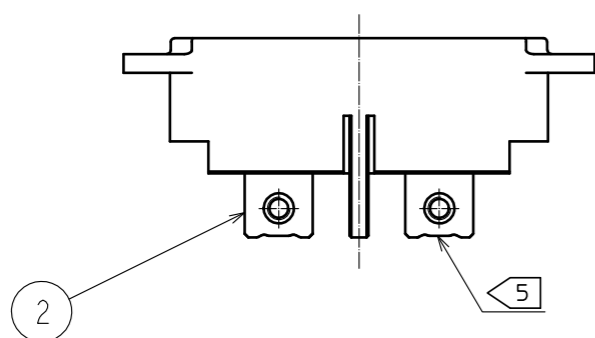
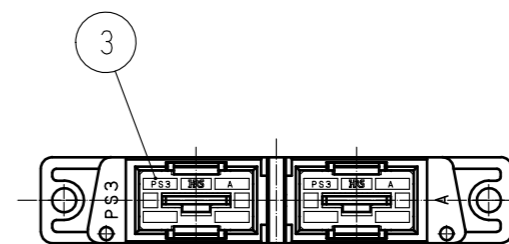
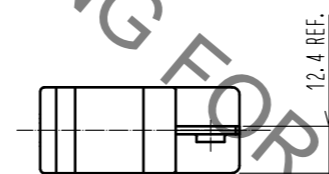
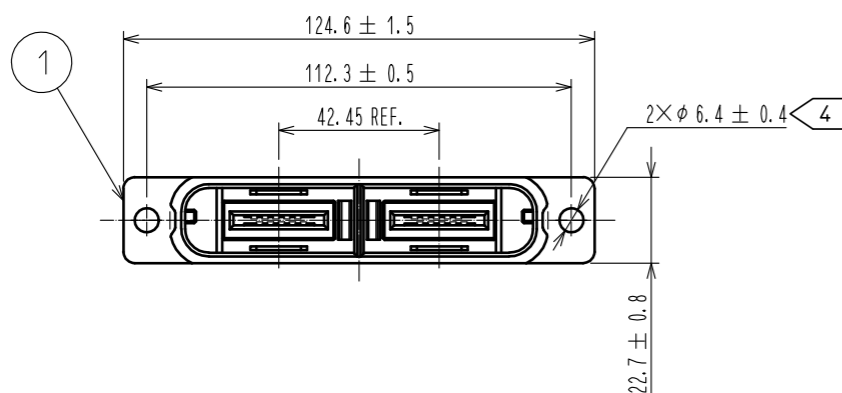
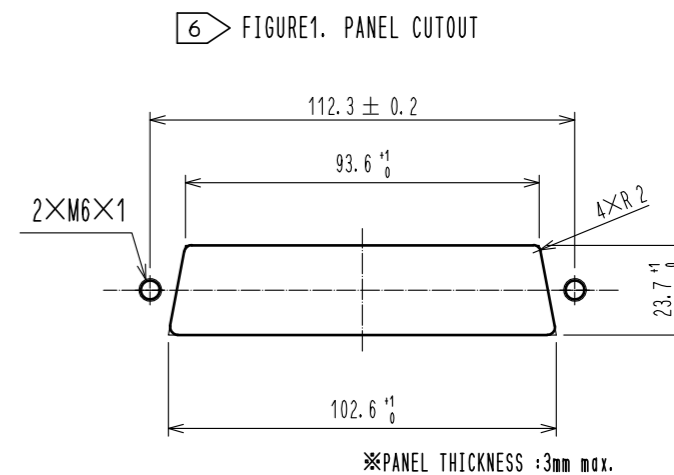
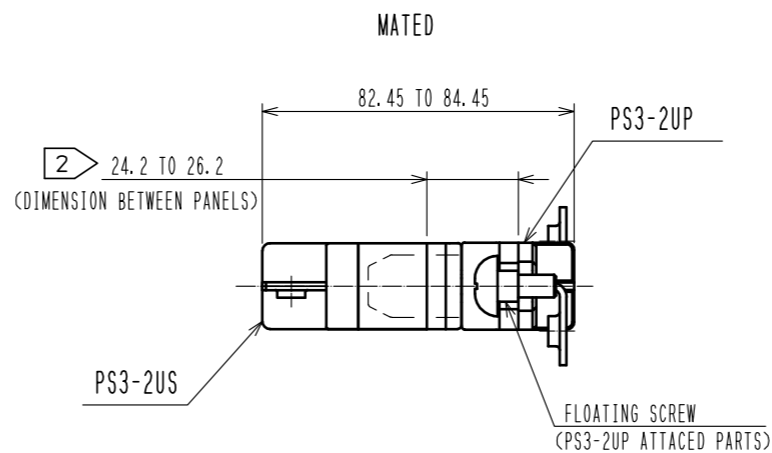
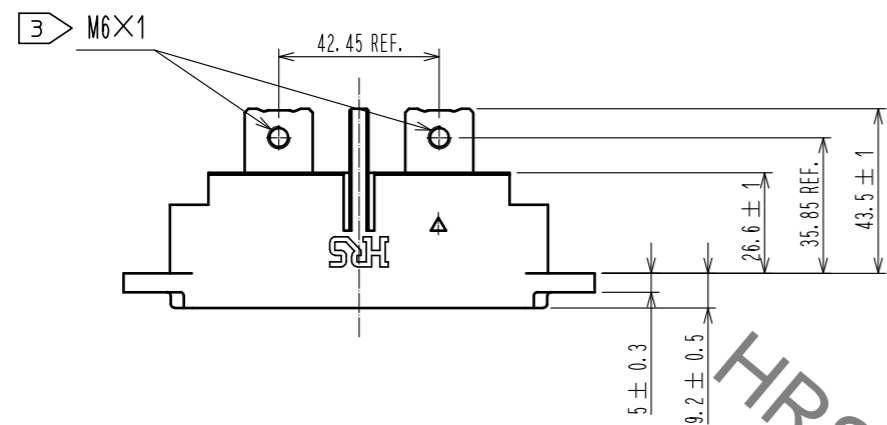

HRS DRAWING FOR REFERENCE

1	PBT	BLACK.	UL94V-0	3	PBT	BLACK.	UL94V-0	
2	COPPER ALLOY			2	COPPER ALLOY	SILVER PLATING	3μm MIN	
NO.	MATERIAL	FINISH . REMARKS		NO.	MATERIAL	FINISH . REMARKS		
UNITS	⊕	SCALE	COUNT	DESCRIPTION OF REVISIONS		DESIGNED	CHECKED	DATE
mm		1 : 2	△					
<b>HRS</b> HIROSE ELECTRIC CO., LTD.		APPROVED : NM. NISHIMATSU	15.07.30	DRAWING NO. EDC-128047-01-00				
		CHECKED : NM. NISHIMATSU	15.07.30	PART NO. PS3-2US(C01)				
		DESIGNED : MO. SHIMOYAMA	15.07.29	CODE NO. CL236-1041-0-01				
		DRAWN : MO. SHIMOYAMA	15.07.29					1/2

Aug.1.2021 Copyright 2021 HIROSE ELECTRIC CO., LTD. All Rights Reserved.  
In case of consideration for using Automotive equipment / device which demand high reliability, kindly contact our sales window correspondents.

⑦ CONDITION OF SAFETY STANDARD(CUL, C-UL, TUV STANDARD)

⑦

TABLE 1. UL, C-UL CONDITION

	CONDITION 1	CONDITION 2
CURRENT VOLTAGE(AC/DC)	600V	
CURRENT RATING	100A	150A
CABLE	14 TO 22sq(※1)	38 TO 50sq(※1)
CREEPAGE DISTANCE(※2)	MIN:3.2mm	
CLEARANCE DISTANCE(※2)	MIN:3.2mm	

⑦

TABLE 2. TUV CONDITON

	CONDITION I	CONDITION II	CONDITION III
CURRENT VOLTAGE(AC/DC)	800V	600V	1000V
CURRENT RATING	100A(CABLE 14 TO 22sq ※1) 125A(CABLE 38sq ※1) 150A(CABLE 50sq ※1)		
OVER VOLTAGE CATEGORY	II	III	
POLLUTION DEGREE	3		
CREEPAGE DISTANCE(※2)	MIN:12.6mm	MIN:12.6mm	MIN:16mm
CLEARANCE DISTANCE(※2)	MIN:6mm	MIN:6mm	MIN:8mm
INSULATION SYSTEM	BASIC INSULATION(PANEL HAS THE EARTH)		

※1 : AS SCREWS AND CRIMP TERMINAL ATTACHED WITH POWER CONTACT HAVE AN IMPACT ON THE CREEPAGE DISTANCE AND THE CLEARANCE DISTANCE, PLEASE USE RECOMMENDED SCREWS AND CRIMP TERMINALS.  
IN CASE YOU USE CABLES OTHER THAN FOLLOWING RECOMMENDED SCREWS AND CONTACTS,  
PLEASE BE CAREFUL THAT THE CREEPAGE DISTANCE AND THE CLEARANCE DISTANCE MEET THE STANDARD OF UL, C-UL, TUV.

※2 : THE COVERAGE OF THE CREEPAGE DISTANCE AND THE CLEARANCE DISTANCE IS AS FOLLOWS.  
-BETWEEN CRIMP TERMINALS  
-BETWEEN POWER CONTACT AND PANEL  
-BETWEEN CRIMP TERMINAL AND PANEL  
-BETWEEN SCREWS (ATTACHED WITH POWER CONTACT) AND PANEL

NOTE 1. THE MATING PARTNER OF THIS PRODUCT IS PS3-2UP(CL236-1042-2-00).

② PLEASE SET THE DISTANCE BETWEEN PANELS AS 24.2 TO 26.2mm.

③ THE TIGHTNING TORQUE FOR THE SCREW ATTACHED WITH REF NO. ② IS 2.5 TO 5.2 N · m.  
THE RECOMMENDED SCREW AND CRIMP TERMINAL IS AS FOLLOWS.  
-RECOMMENDED SCREW : JIS B 1188 SPRING WASHER + CROSS RECESSED PAN HEAD SCREW WITH CAPTIVE POLISHED CIRCULAR WASHER M6 × 12  
-RECOMMENDED CRIMP TERMINAL  
CABLE 14sq : JIS C 2805 R14-6  
CABLE 22sq : JIS C 2805 R22-6  
CABLE 38sq : MANUFACTURED BY NICHIFU CO., LTD R38-6S  
CABLE 50sq : MANUFACTURED BY NICHIFU CO., LTD R60-6S

④ THE SCREW USED TO ATTACH THE PANEL IS M6.  
THE TIGHTNING TORQUE FOR SCREW IS 2.5 TO 5.2 N · m.

⑤ SINCE THE POWER CONTACTS ARE SILVER PLATED, THEY MAY REACT WITH SULFIDE IN THE ATMOSPHERE TO CHANGE THE COLOUR TO BLACKISH BROWN.

⑥ PLEASE SEE THE FIGURE 1 FOR THE RECOMMENDED PANEL DIMENSION.

⑦ THIS ITEM IS APPROVED BY SAFETY STANDARD(CUL, C-UL, TUV STANDARD)  
UNDER THE CONDITION OF TABLE 1 AND TABLE 2  
SAFETY STANDARD IS DEFERENT UP TO THE APPLIED RATED VOLTAGE AND CURRENT  
PLEASE SEE THE TABLE 1 AND TABLE 2.

8. THE POWER CONTACT OF THIS PRODUCT IS NOT APPLICABLE FOR HOT-SWAP.  
IT CAN NOT BE USED TO INTERRUPT THE POWER.

**HRS**

DRAWING NO.	EDC-128047-01-00
PART NO.	PS3-2US(01)
CODE NO.	CL236-1041-0-01

△ 2/2