

Jan.1.2025 Copyright 2025 HIROSE ELECTRIC CO., LTD. All Rights Reserved.
 In case of consideration for using Automotive equipment / device which demand high reliability, kindly contact our sales window correspondents.

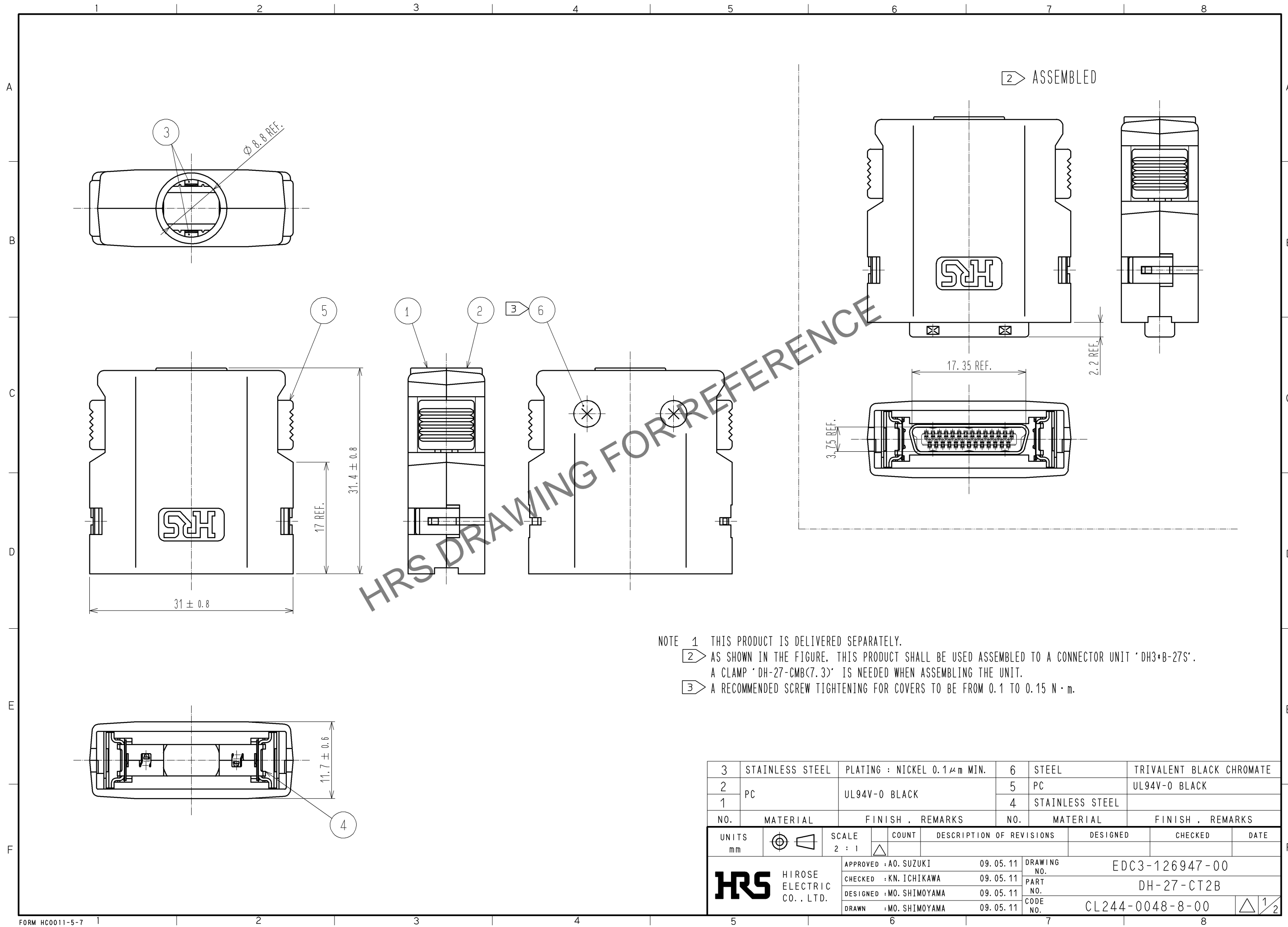

NOTE 1 THIS PRODUCT IS DELIVERED SEPARATELY.
 2 AS SHOWN IN THE FIGURE, THIS PRODUCT SHALL BE USED ASSEMBLED TO A CONNECTOR UNIT 'DH3+B-27S'.
 A CLAMP 'DH-27-CMB(7.3)' IS NEEDED WHEN ASSEMBLING THE UNIT.
 3 A RECOMMENDED SCREW TIGHTENING FOR COVERS TO BE FROM 0.1 TO 0.15 N · m.

3	STAINLESS STEEL	PLATING : NICKEL 0.1 μm MIN.	6	STEEL	TRIVALENT BLACK CHROMATE
2	PC	UL94V-0 BLACK	5	PC	UL94V-0 BLACK
1			4	STAINLESS STEEL	
NO.	MATERIAL	FINISH . REMARKS	NO.	MATERIAL	FINISH . REMARKS
UNITS mm		SCALE 2 : 1	COUNT △	DESCRIPTION OF REVISIONS	
DESIGNED		CHECKED		DATE	
APPROVED : A0. SUZUKI 09. 05. 11			DRAWING NO. EDC3-126947-00		
CHECKED : KN. ICHIKAWA 09. 05. 11			PART NO. DH-27-CT2B		
DESIGNED : MO. SHIMOYAMA 09. 05. 11			CODE NO. CL244-0048-8-00		
DRAWN : MO. SHIMOYAMA 09. 05. 11			△ 1/2		

Jan.1.2025 Copyright 2025 HIROSE ELECTRIC CO., LTD. All Rights Reserved.
In case of consideration for using Automotive equipment / device which demand high reliability, kindly contact our sales window correspondents.

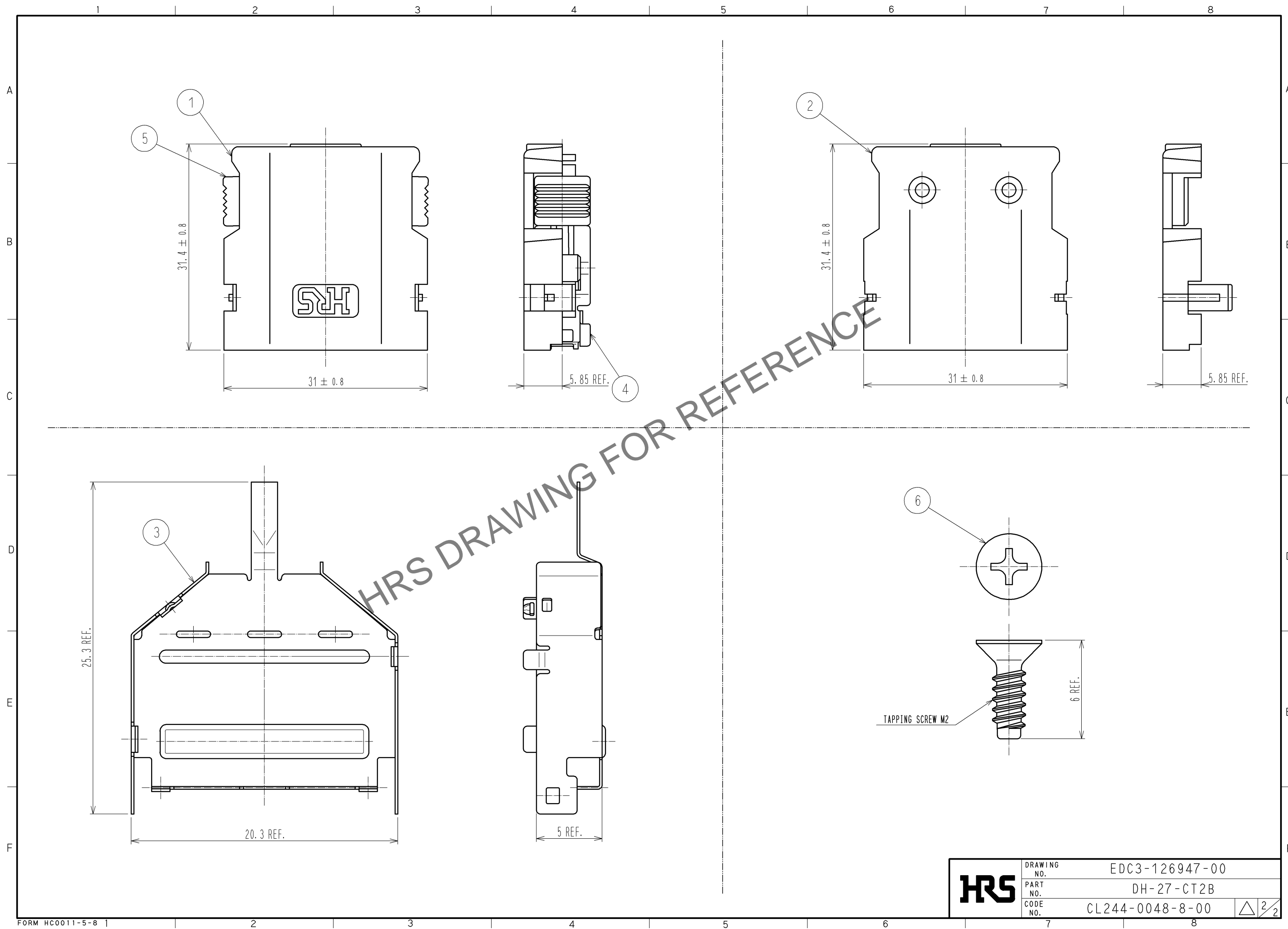

HRS	DRAWING NO.	EDC3-126947-00
	PART NO.	DH-27-CT2B
	CODE NO.	CL244-0048-8-00
		△ 2/2