

May.1.2021 Copyright 2021 HIROSE ELECTRIC CO., LTD. All Rights Reserved.
 In case of consideration for using Automotive equipment / device which demand high reliability, kindly contact our sales window correspondents.

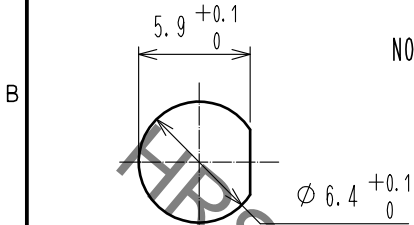
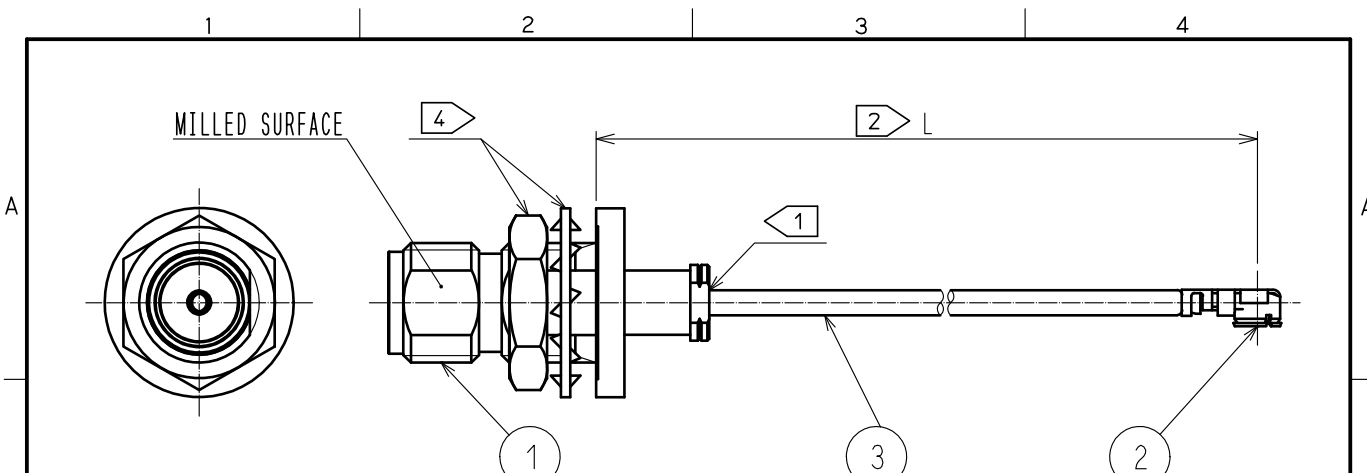

PANEL CUT OUT(REFERENCE)
 PANEL THICKNESS:0.7~2.2mm

- NOTE 1 Do not apply any excessive stress to the cable assembly position.
 2 We indicate the length of the harness on the last of product name. 'L' part.

Tolerance for [L]

Length L [mm]	Tolerance [mm]
$\triangle 50 \leq L \leq 200$	± 4
$200 < L \leq 500$	± 8
$500 < L \leq 1000$	± 12
$1000 < L$	$\pm 1.5\%$

Part No.	Cable color
~066N1~	GRAY
~066N2~	BLACK
~066N3~	WHITE

3. Connector rotation angle is within ± 45 degree from the above image. For long length in the case of $L > 500$, the angle is optional.
 4 Lock nut and tooth washer are attached separately in other package.
 5. Specifications are subject to change without notice.

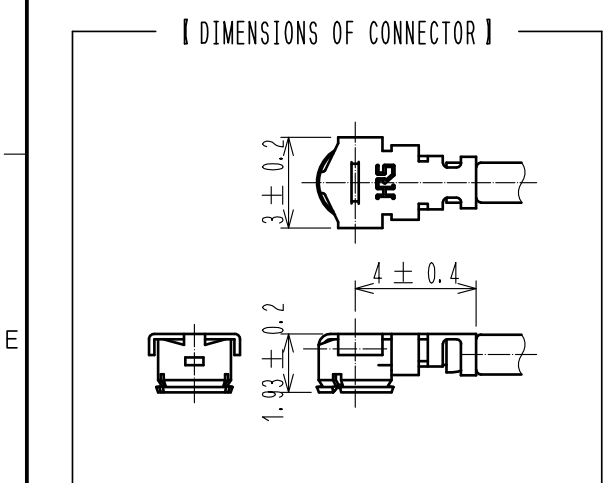

【 PRECAUTIONS FOR HANDLING 】

- ◆ Connector insertion and extraction
 - a. Connector shall be extracted vertically by specialised extraction JIG. Part No.:U.FL-LP-N-2(CCL Code:CL331-0494-5) Never hold the cable when extracting the cable because it damages the connector.
 - b. Insert the connector as perpendicularly to the mating surface as possible by aligning the mating axes of both connectors. Do not excessively slant the connectors when inserting.
- ◆ Allowable loads on the cable after the connectors are mated. The figures below show the maximum allowable loads on the cable. Do not apply loads exceeding these values to the cable.

2	U.FL-LP-066HF	CL331-0558-6-00					
1	HRM-200-066BPJBN(40)	CL323-0798-5-40	3	RF-MF5013 NISSEI ELECTRIC CO.,LTD.			
N o.	PART NO.	CODE NO.	N o.	PART NO.	MANUFACTURER		
UNITS mm		SCALE FREE	COUNT \triangle 1	DESCRIPTION OF REVISIONS DIS-D-00003732	DESIGNED NK. OOSAWA	CHECKED TO. KATAYAMA	DATE 20181206
HRS HIROSE ELECTRIC CO., LTD.	APPROVED :TO. KATAYAMA	20180721	DRAWING NO.				
	CHECKED :TO. KATAYAMA	20180721	PART NO. HBPJ-UFLHF6-066N* -ALRS				
	DESIGNED :YI. FUNADA	20180721	CODE NO.				
	DRAWN :YI. FUNADA	20180721	\triangle 1 / 1				