

Apr.1.2025 Copyright 2025 HIROSE ELECTRIC CO., LTD. All Rights Reserved.
In case of consideration for using Automotive equipment / device which demand high reliability, kindly contact our sales window correspondents.

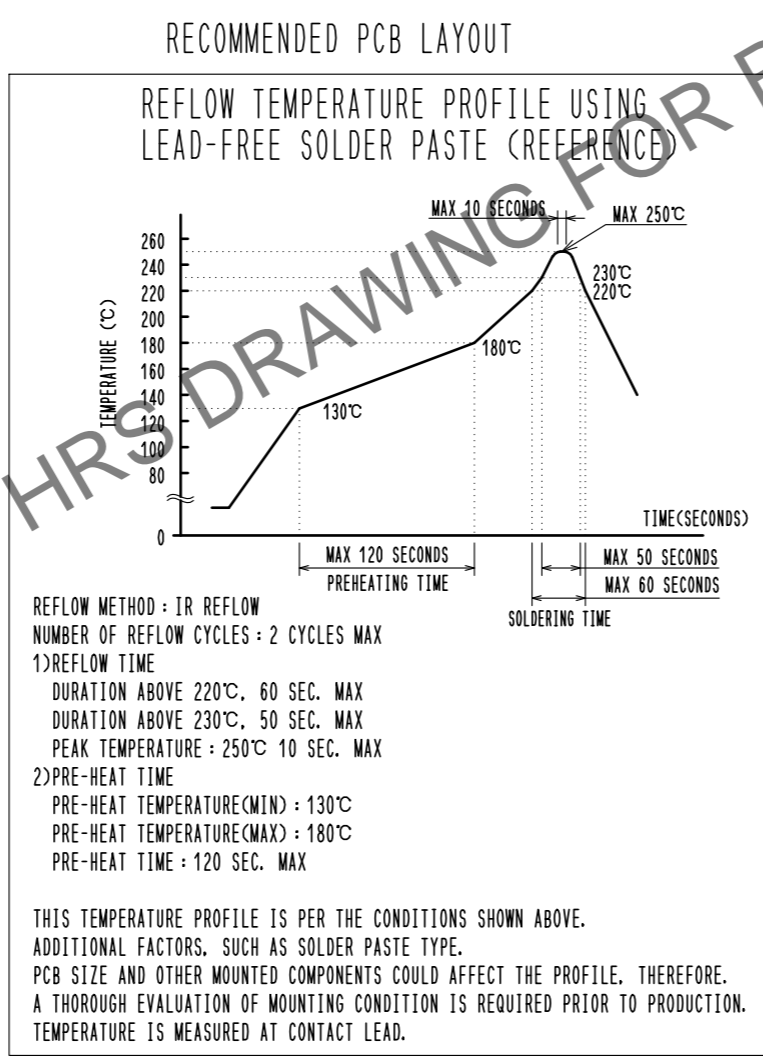
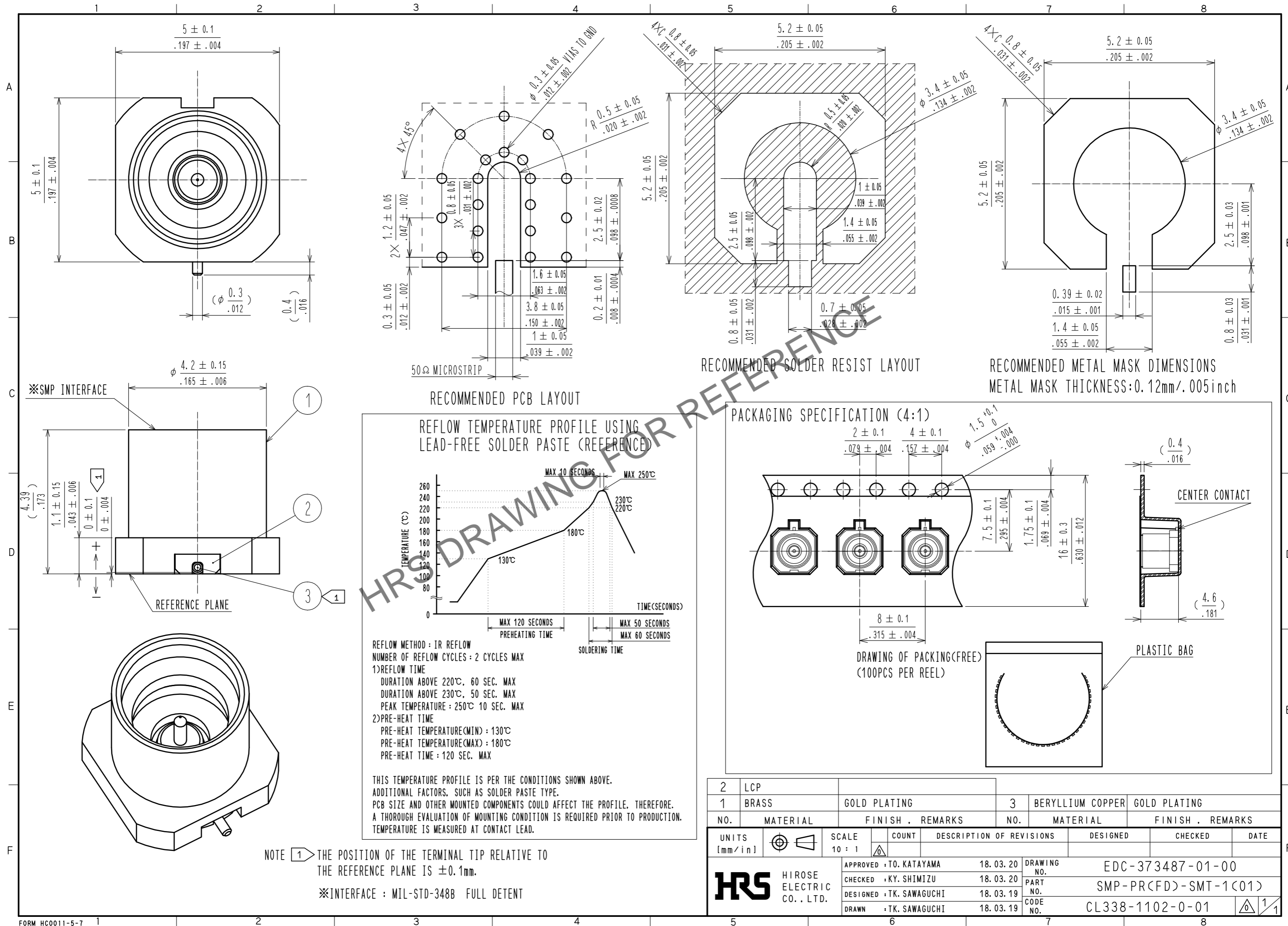

RECOMMENDED SOLDER RESIST LAYOUT

RECOMMENDED METAL MASK DIMENSIONS
 METAL MASK THICKNESS: 0.12mm/.005inch

PACKAGING SPECIFICATION (4:1)

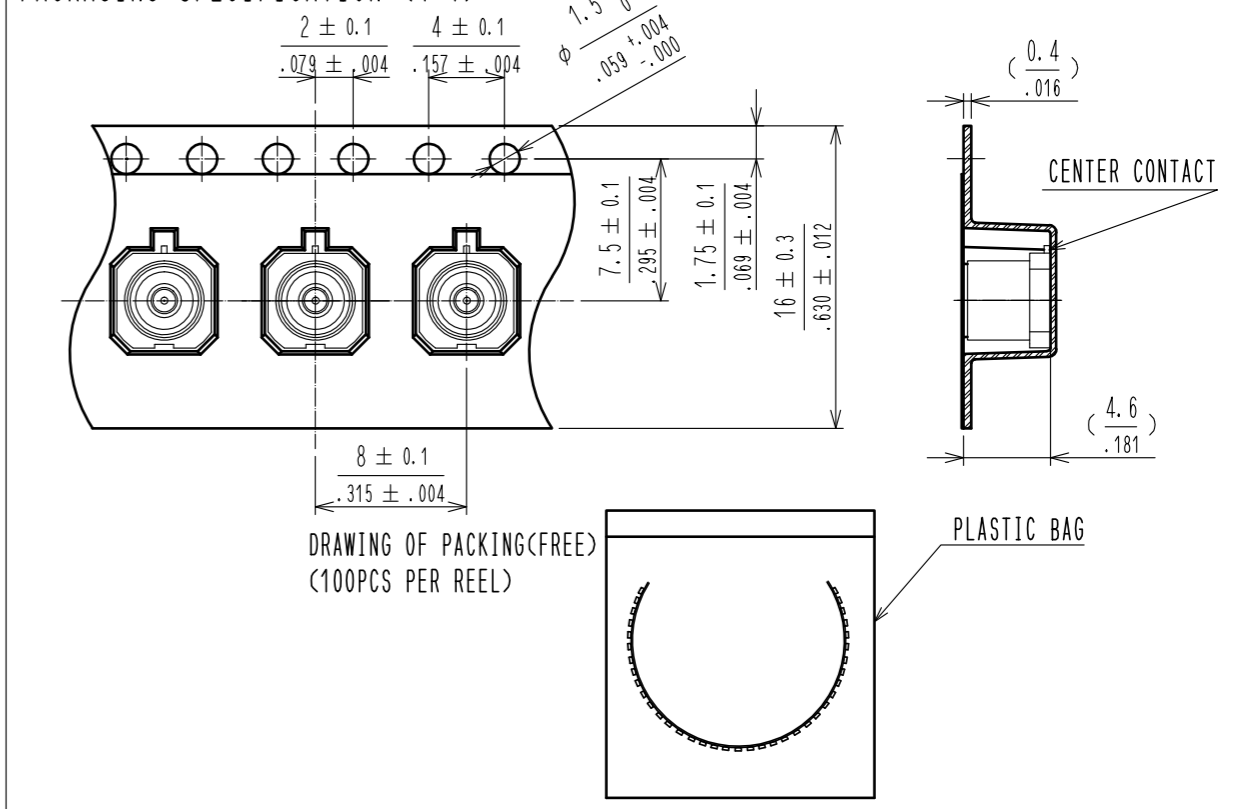

NOTE ① THE POSITION OF THE TERMINAL TIP RELATIVE TO THE REFERENCE PLANE IS ±0.1mm.

※INTERFACE : MIL-STD-348B FULL DETENT

2	LCP			3	BERYLLIUM COPPER	GOLD PLATING		
1	BRASS	GOLD PLATING						
NO.	MATERIAL	FINISH	REMARKS	NO.	MATERIAL	FINISH	REMARKS	
UNITS [mm/in]	①	SCALE 10:1	COUNT	DESCRIPTION OF REVISIONS		DESIGNED	CHECKED	DATE
APPROVED : TO. KATAYAMA		18.03.20		DRAWING NO.		EDC-373487-01-00		
CHECKED : KY. SHIMIZU		18.03.20		PART NO.		SMP-PR(FD)-SMT-1(C01)		
DESIGNED : TK. SAWAGUCHI		18.03.19		CODE NO.		CL338-1102-0-01		
DRAWN : TK. SAWAGUCHI		18.03.19						