

May.1.2024 Copyright 2024 HIROSE ELECTRIC CO., LTD. All Rights Reserved.  
 In case of consideration for using Automotive equipment / device which demand high reliability, kindly contact our sales window correspondents.

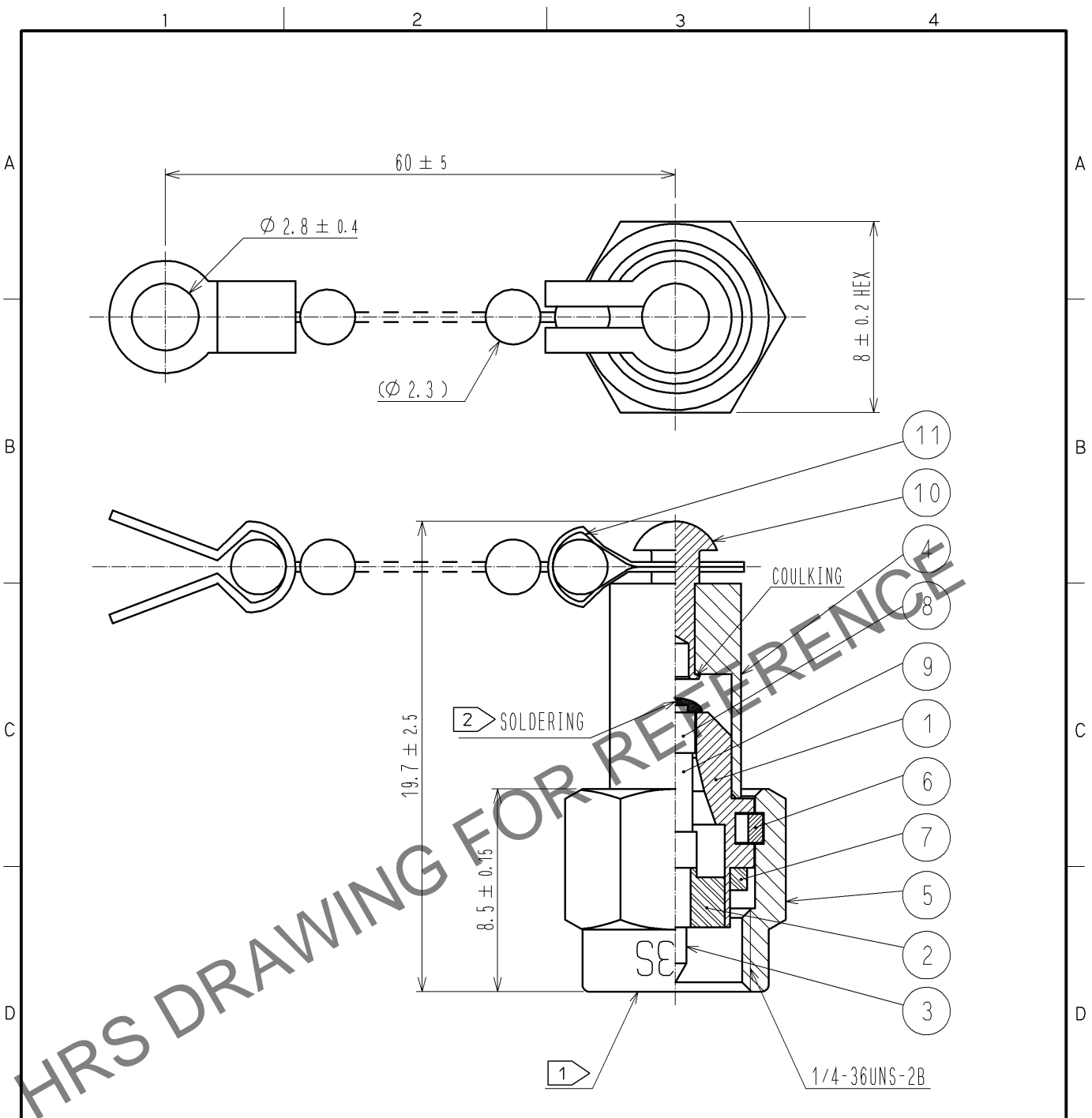

NOTE 1 603S SHALL BE INDICATED AT THE POSITION AS SHOWN.  
 HRM AT THE REVERSE SIDE.  
2 USE LEAD FREE SOLDER(Sn3.0Ag0.5Cu).

6	BERYLLIUM COPPER	NICKEL PLATING		11	BRASS	CHROME PLATING	
5	STAINLESS STEEL	PASSIVATE		10	ALUMINUM		
4	BRASS	NICKEL PLATING		9	RESISTANCE	50Ω	
3	BRASS	GOLD PLATING		8	BRASS	GOLD PLATING	
2	PTFE			7	SILICONE RUBBER		
1	STAINLESS STEEL	NICKEL PLATING					
NO.	MATERIAL	FINISH	REMARKS	NO.	MATERIAL	FINISH	REMARKS

UNITS	SYMBOLS	SCALE	COUNT	DESCRIPTION OF REVISIONS	DESIGNED	CHECKED	DATE
mm		4 : 1					
HIROSE ELECTRIC CO., LTD.				APPROVED : MT. SHIBUTANI	12.03.23	DRAWING NO. EDC4-030173-01	
				CHECKED : KY. SHIMIZU	12.03.23	PART NO. HRM-603S(50)	
				DESIGNED : TK. SAWAGUCHI	12.03.22	CODE NO. CL353-0062-8-50	
				DRAWN : TK. SAWAGUCHI	12.03.22	1/1	