

Mar.1.2025 Copyright 2025 HIROSE ELECTRIC CO., LTD. All Rights Reserved.
In case of consideration for using Automotive equipment / device which demand high reliability, kindly contact our sales window correspondents.

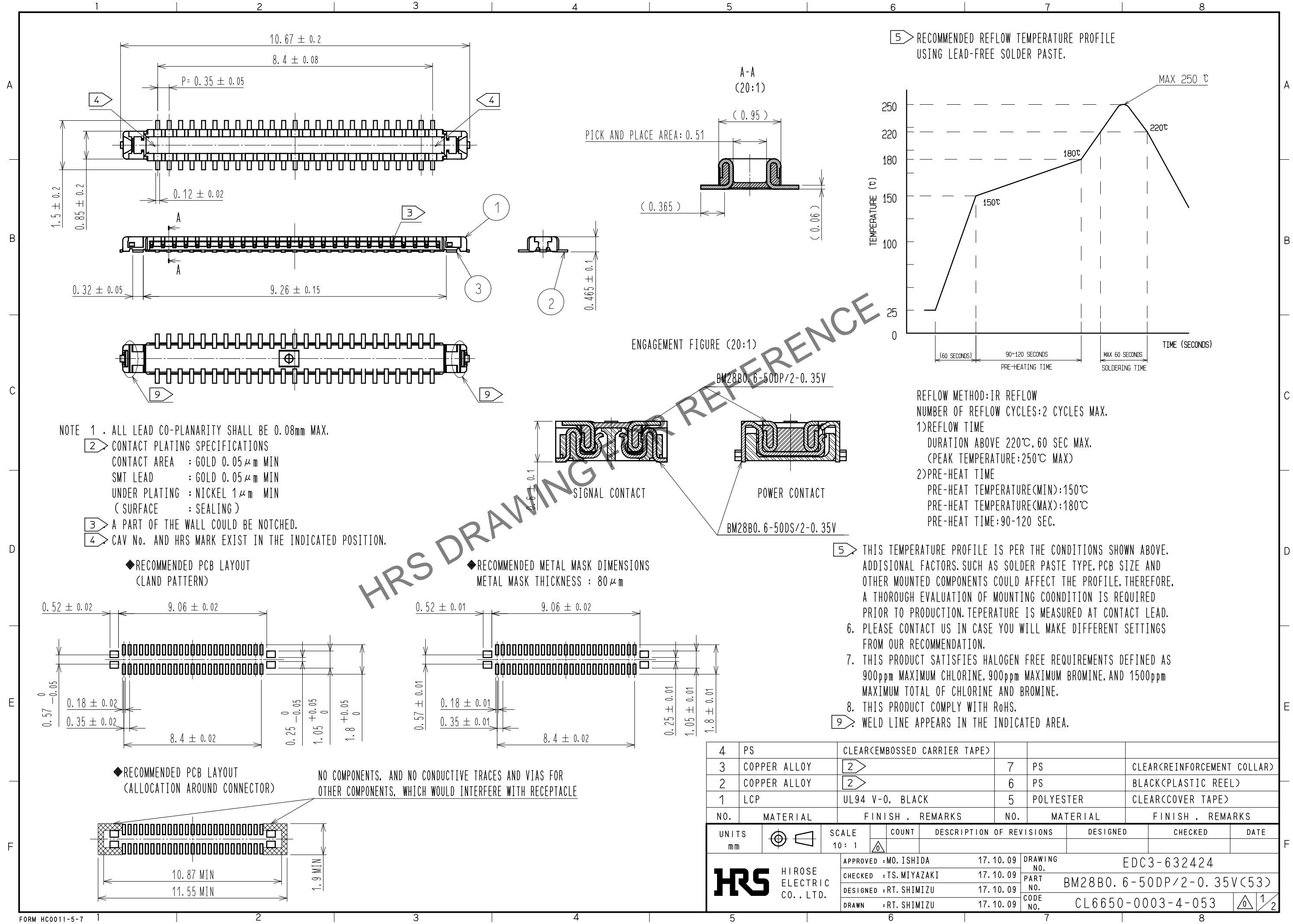

4	PS	CLEAR(EMBOSSED CARRIER TAPE)			
3	COPPER ALLOY	2	7	PS	CLEAR(REINFORCEMENT COLLAR)
2	COPPER ALLOY	2	6	PS	BLACK(PLASTIC REEL)
1	LCP	UL94 V-0, BLACK	5	POLYESTER	CLEAR(COVER TAPE)
NO.	MATERIAL	FINISH . REMARKS	NO.	MATERIAL	FINISH . REMARKS
UNITS		SCALE	COUNT	DESCRIPTION OF REVISIONS	
mm		10:1	△	DESIGNED	CHECKED
HRS		APPROVED : MO. ISHIDA	17.10.09	DRAWING NO. EDC3-632424	
HIROSE ELECTRIC CO., LTD.		CHECKED : TS. MIYAZAKI	17.10.09	PART NO. BM28B0. 6-50DP/2-0.35V(53)	
		DESIGNED : RT. SHIMIZU	17.10.09	CODE NO. CL6650-0003-4-053	
		DRAWN : RT. SHIMIZU	17.10.09	DATE	

Mar.1.2025 Copyright 2025 HIROSE ELECTRIC CO., LTD. All Rights Reserved.
 In case of consideration for using Automotive equipment / device which demand high reliability, kindly contact our sales window correspondents.

EMBOSSED CARRIER TAPE PACKAGING (5:1)

STYLE AND DIMENSION OF REEL (FREE)

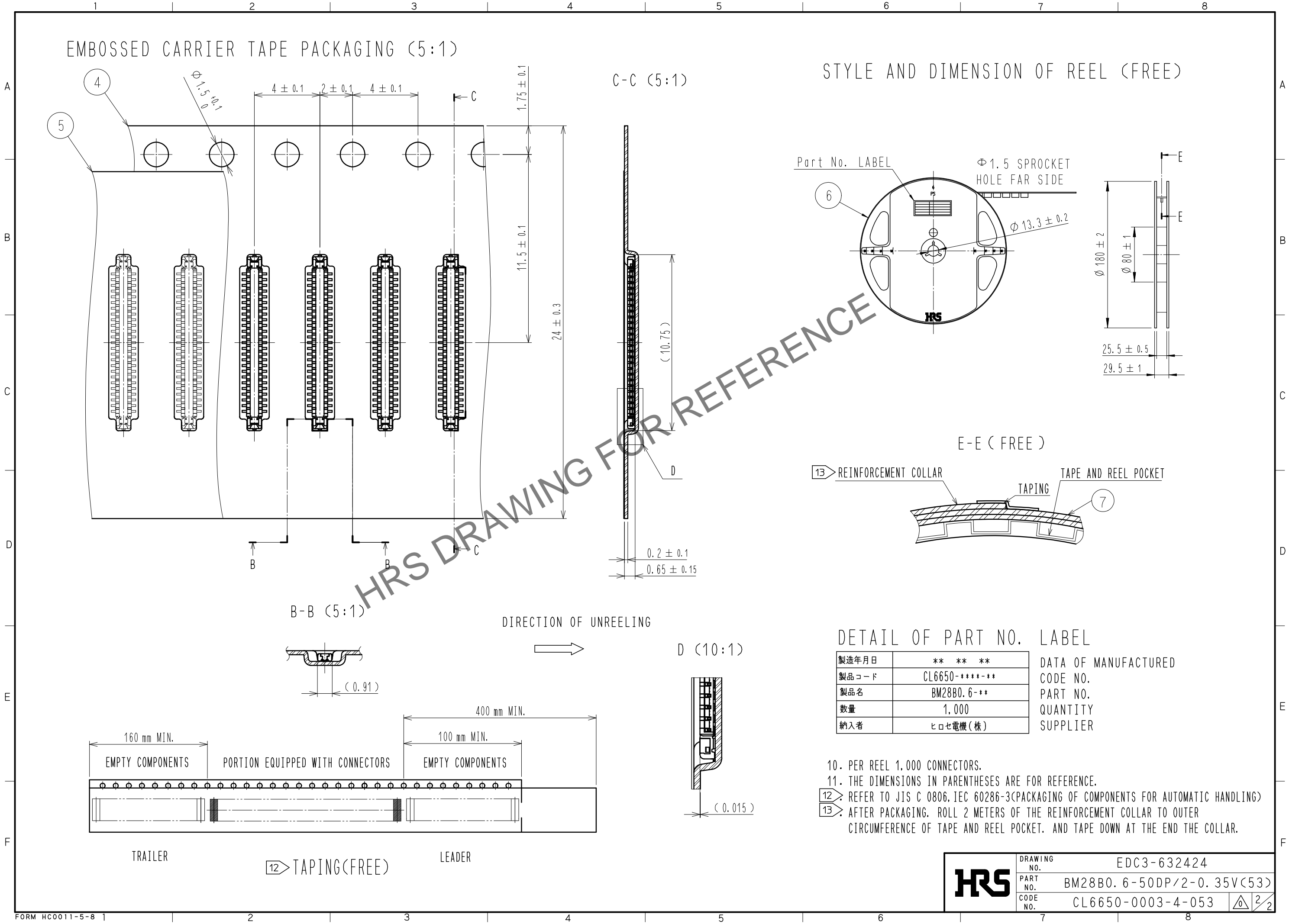

HRS DRAWING FOR REFERENCE

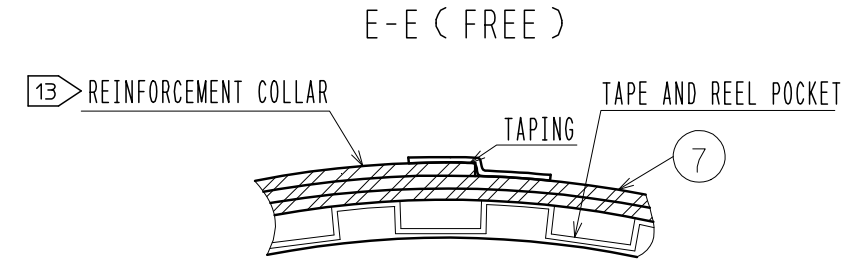
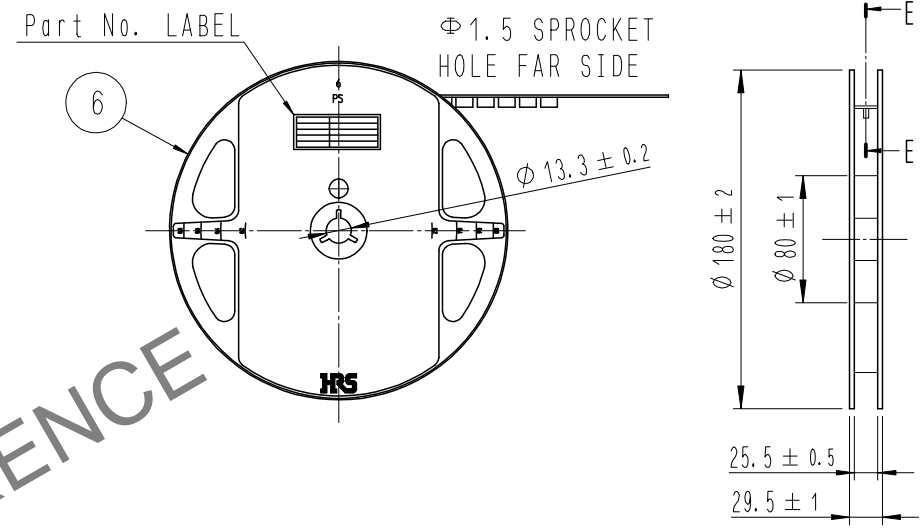

DETAIL OF PART NO. LABEL

製造年月日	** ** *	DATA OF MANUFACTURED
製品コード	CL6650-****-**	CODE NO.
製品名	BM28B0.6-**	PART NO.
数量	1,000	QUANTITY
納入者	ヒロセ電機(株)	SUPPLIER

- 10. PER REEL 1,000 CONNECTORS.
- 11. THE DIMENSIONS IN PARENTHESES ARE FOR REFERENCE.
- 12. REFER TO JIS C 0806. IEC 60286-3(PACKAGING OF COMPONENTS FOR AUTOMATIC HANDLING)
- 13. AFTER PACKAGING, ROLL 2 METERS OF THE REINFORCEMENT COLLAR TO OUTER CIRCUMFERENCE OF TAPE AND REEL POCKET. AND TAPE DOWN AT THE END THE COLLAR.

HRS	DRAWING NO.	EDC3-632424
	PART NO.	BM28B0.6-50DP/2-0.35V(53)
	CODE NO.	CL6650-0003-4-053
		2/2