

# 0.4mm Pitch, 0.9mm Height, Bottom Contact, Back Flip/Front Axis™, FPC/FFC Connector

## TF13B(S)A Series

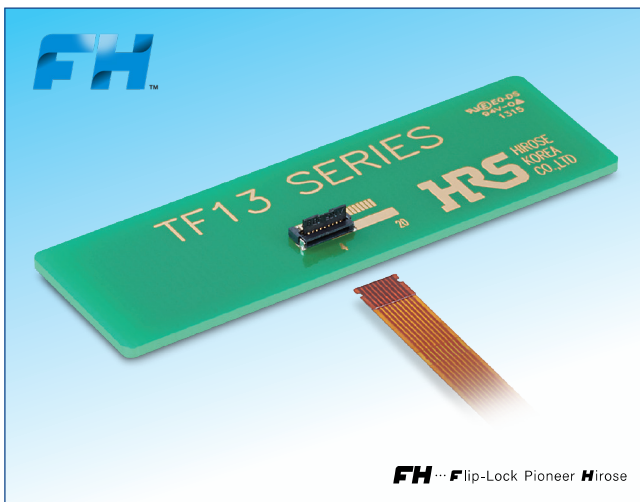

### Features

#### 1. Back Flip/Front Axis™

Secures a constant contact gap regardless of actuator operation. The actuator can be closed before FPC/FFC is inserted. (Fig.1)

Furthermore, since the actuator can be delivered and mounted in a closed state, the risk of damage to the actuator is reduced. (Fig.2)

#### 2. Prevents actuator from coming off

Each terminal is attached to the actuator, which provides support to the actuator across its entire length. This prevents the actuator from separating from the housing. (Fig.3)

#### 3. FPC/FFC side catcher design

The TF13B(S)A Series incorporates Hirose's FPC/FFC side catcher technology. This design feature enables the tabbed FPC/FFC to be placed in the correct position while achieving stability and excellent FPC/FFC retention force.

#### 4. Easy FPC/FFC insertion

Tapers on all four sides at the FPC/FFC insertion part enables smooth FPC/FFC insertion.

#### 5. Maximizes board space

The bottom surface of the connector is over-molded. This allows the PCB space under the connector to be utilized for additional PCB routing.

#### 6. Pick & Place Mounting

Offered in tape and reel packaging that is compatible with automatic machine mounting.

#### 7. Halogen-Free

All materials and substances used to produce this product comply with Halogen-Free standards.

\*As defined by IEC 61249-2-21

Br : 900ppm max., Cl : 900ppm max., Br+Cl : 1,500ppm max.

#### Back Flip/Front Axis™

A constant contact gap is maintained for actuator opening and closing.

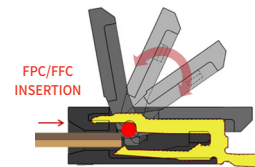

No effect on the contact from actuator operation  
⇒ Superior FPC Insertion

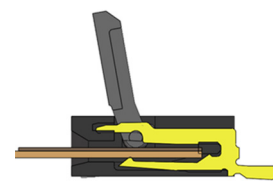
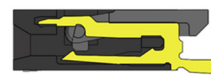

Fig.1

#### Back Flip/Front Axis™

##### Actuator Damage Prevention

- Height of Conventional Back Flip and TF13B(S)A Series when stacking in a rack

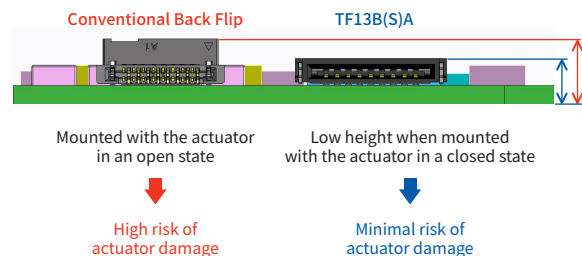
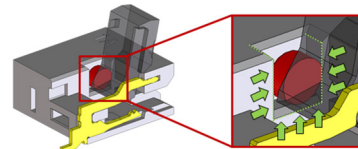

Fig.2

#### Prevents Actuator Breakage

- Case Part



- Contact Part

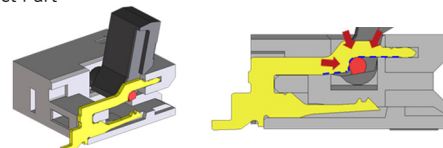

The actuator does not come off during operation.

Fig.3

## Product Specifications

Ratings	Rated Current : 0.5A ( Note1)	Operating Temperature : -55 to +85 °C (Note2) Operating Humidity Range : Relative humidity, 90% Max. (No condensation)	Storage Temperature : -10 to +50 °C (Note3) Storage Humidity Range : Relative humidity, 90% Max. (No condensation)
	Rated Voltage : 50V AC/DC		

Adaptive FPC/FFC contact specifications	Thickness : 0.2±0.03mm Gold plated contact traces
---	---

Items	Specifications	Conditions
1. Insulation Resistance	500mΩ Min.	100V DC
2. Withstanding Voltage	No flashover or insulation breakdown	150V AC rms for 1 min.
3. Contact Resistance	100mΩ Max. Including FPC/FFC conductor resistance	1mA
4. Mating Durability (Insertion/withdrawal)	Contact resistance : 100mΩ Max. No damage, cracks, or parts dislocation	20 cycles
5. Vibration	No electrical discontinuity for more than 1μs Contact resistance : 100mΩ Max. No damage, cracks, or parts dislocation	Frequency : 10 to 55Hz, Half Amplitude 0.75mm for 2hours in 3 axis directions
6. Shock Resistance	No electrical discontinuity of 1μs or more Contact resistance : 100mΩ Max. No damage, cracks, or parts dislocation	Acceleration : 981m/s <sup>2</sup> , 6ms duration, Sine half-waveform, 3 cycles in each of the 3 axis.
7. Humidity (Steady State)	Contact resistance : 100mΩ Max. Insulation resistance : 100mΩ Min. No damage, cracks, or parts dislocation	96 hours at a temperature of 40°C and humidity of 90% to 95%
8. Temperature Cycle	Contact resistance : 100mΩ Max. Insulation resistance : 100mΩ Min. No damage, cracks, or parts dislocation	Temperature : -55 → +15 to +35 → +85 → +15 to +35 °C, Time : 30 → 2 to 3 → 30 → 2 to 3 min. 5 cycles
9. Resistance to Soldering Heat	No deformation of components affecting performance No abnormality in electrical performance	Reflow : At the recommended temperature profile

Note 1 : When passing the current through all of the contacts, use 70% of the current rating.

Note 2 : Includes temperature rise caused by current flow.

Note 3 : The term “storage” refers to products stored for long period of time prior to mounting and use.

Operating temperature range and humidity range covers non-conducting condition of installed connectors in storage, shipment or during transportation.

## Material / Finish

Part	Material	Finish	Remarks
Insulator	LCP	Black	UL94V-0
Actuator	LCP	Black	
Contact	Phosphor Bronze	Partially Gold Plated	-----
Retention Tab	Phosphor Bronze	Tin Plated	

## Product Number Structure

Refer to the chart below when determining the product specifications from the product number.

Please select from the product numbers listed in this catalogue when placing orders.

TF      13      B(S)A - ##S - 0.4      SH      (800)  
 ①            ②            ③            ④            ⑤            ⑥            ⑦

① Series Name : TF	⑤ Contact Pitch : 0.4mm
② Series No. : 13	⑥ Terminal Type SH : SMT Horizontal Mounting Type
③ Connector Type : BA : Length = Pitch x (No. of Pos. -1) + 2.2mm BSA : Length = Pitch x (No. of Pos. -1) + 1.8mm	⑦ Specifications (800) : Standard, Emboss tape packaging (5,000pcs/reel)
④ Number of Contacts : TF13BA : 6, 9, 10pos. TF13BSA : 14, 16, 18, 20pos.	

## ■ Dimensions

### ● TF13BA Series

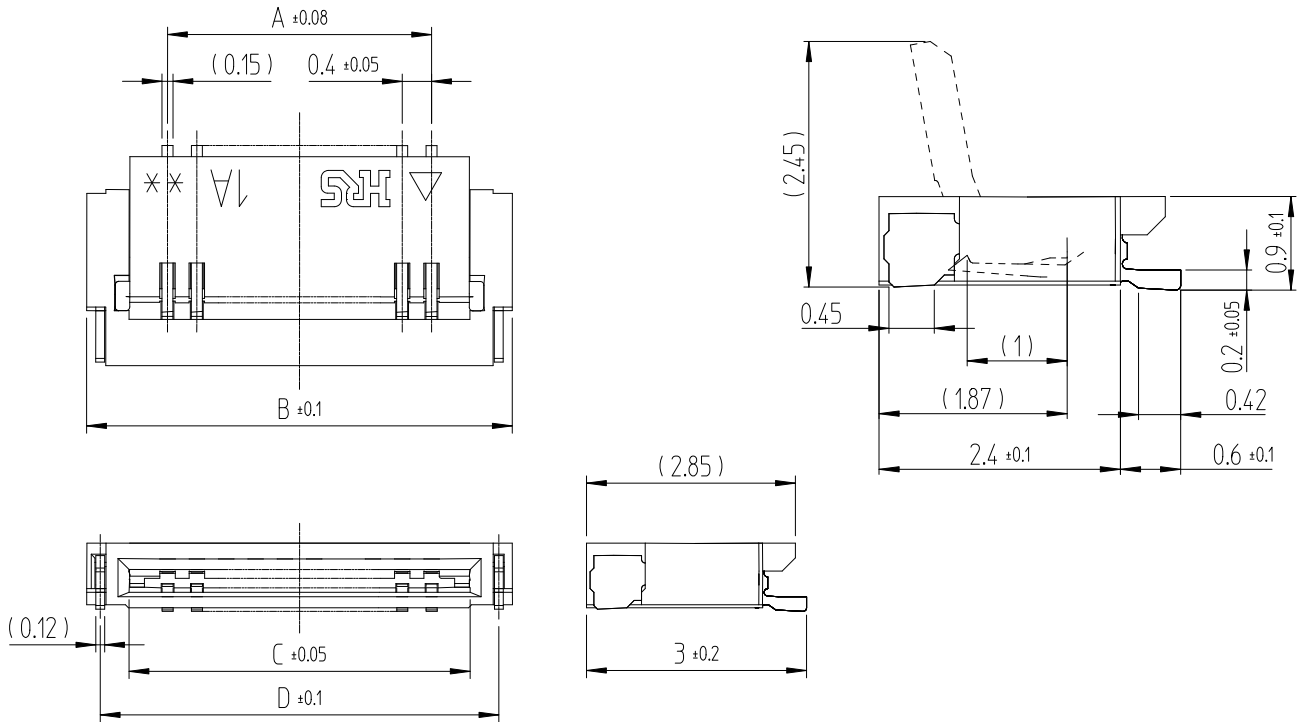

Note 1 : The coplanarity of each terminal lead is within 0.1mm.

Note 2 : This product is packaged and sold by tape and reel. Check the packaging specifications for details.

Note 3 : Sink mark reliefs may be added due to improvements.

Note 4 : Black spots may appear on the mold resin, but this does not affect product performance.

Additionally, the terminal plating may change color after reflow, however this does not represent a quality issue.

Unit : mm

Part No.	HRS No.	No. of Pos.	A	B	C	D	Purchase Unit
TF13BA-6S-0.4SH(800)	480-0340-0 00	6	2.00	4.20	3.05	3.83	5,000pcs/Reel
TF13BA-9S-0.4SH(800)	480-0341-0 00	9	3.20	5.40	4.25	5.03	
TF13BA-10S-0.4SH(800)	480-0495-0 00	10	3.60	5.80	4.65	5.43	

● TF13BSA Series

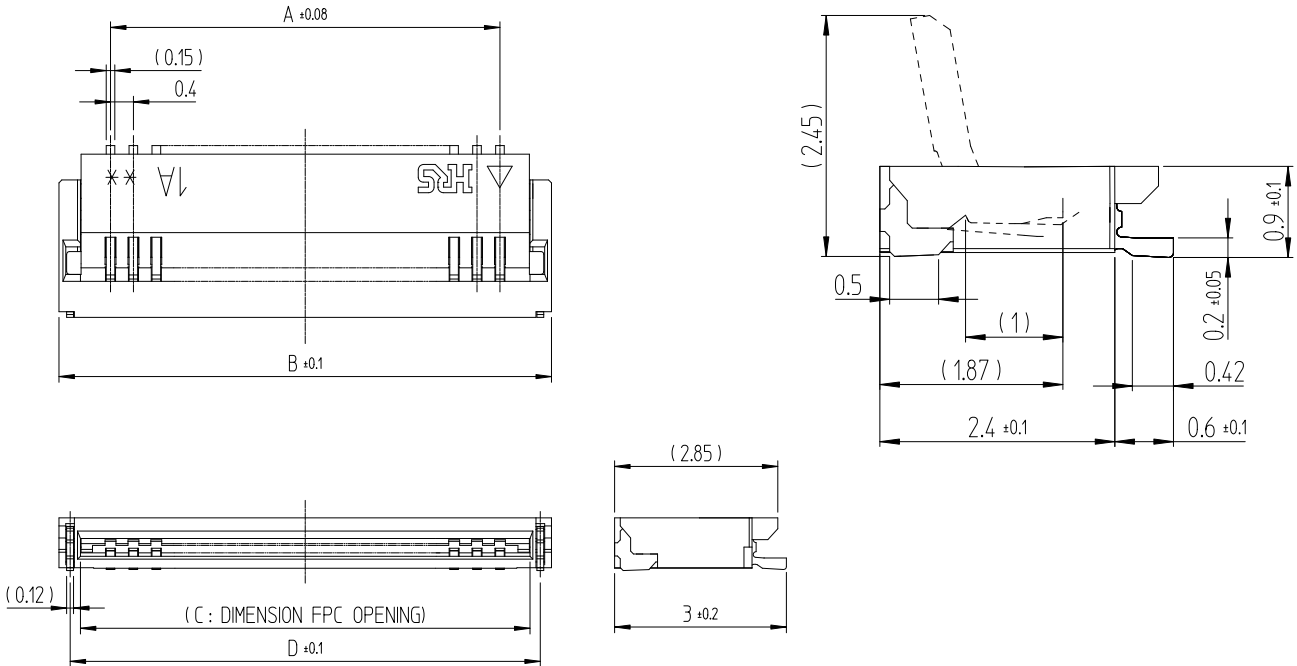

- Note 1 : The coplanarity of each terminal lead is within 0.1mm.
- Note 2 : This product is packaged and sold by tape and reel. Check the packaging specifications for details.
- Note 3 : Sink mark reliefs may be added due to improvements.
- Note 4 : Black spots may appear on the mold resin, but this does not affect product performance.  
 Additionally, the terminal plating may change color after reflow, however this does not represent a quality issue.

Unit : mm

Part No.	HRS No.	No. of Pos.	A	B	C	D	Purchase Unit
TF13BSA-14S-0.4SH(800)	480-0423-0 00	14	5.20	7.00	6.25	6.61	5,000pcs/Reel
TF13BSA-16S-0.4SH(800)	480-0342-0 00	16	6.00	7.80	7.05	7.41	
TF13BSA-18S-0.4SH(800)	480-0343-0 00	18	6.80	8.60	7.85	8.21	
TF13BSA-20S-0.4SH(800)	480-0344-0 00	20	7.60	9.40	8.65	9.01	

## ◆ Recommended Land/Metal Mask Dimensions and FPC/FFC Dimensions

### ● TF13BA Series

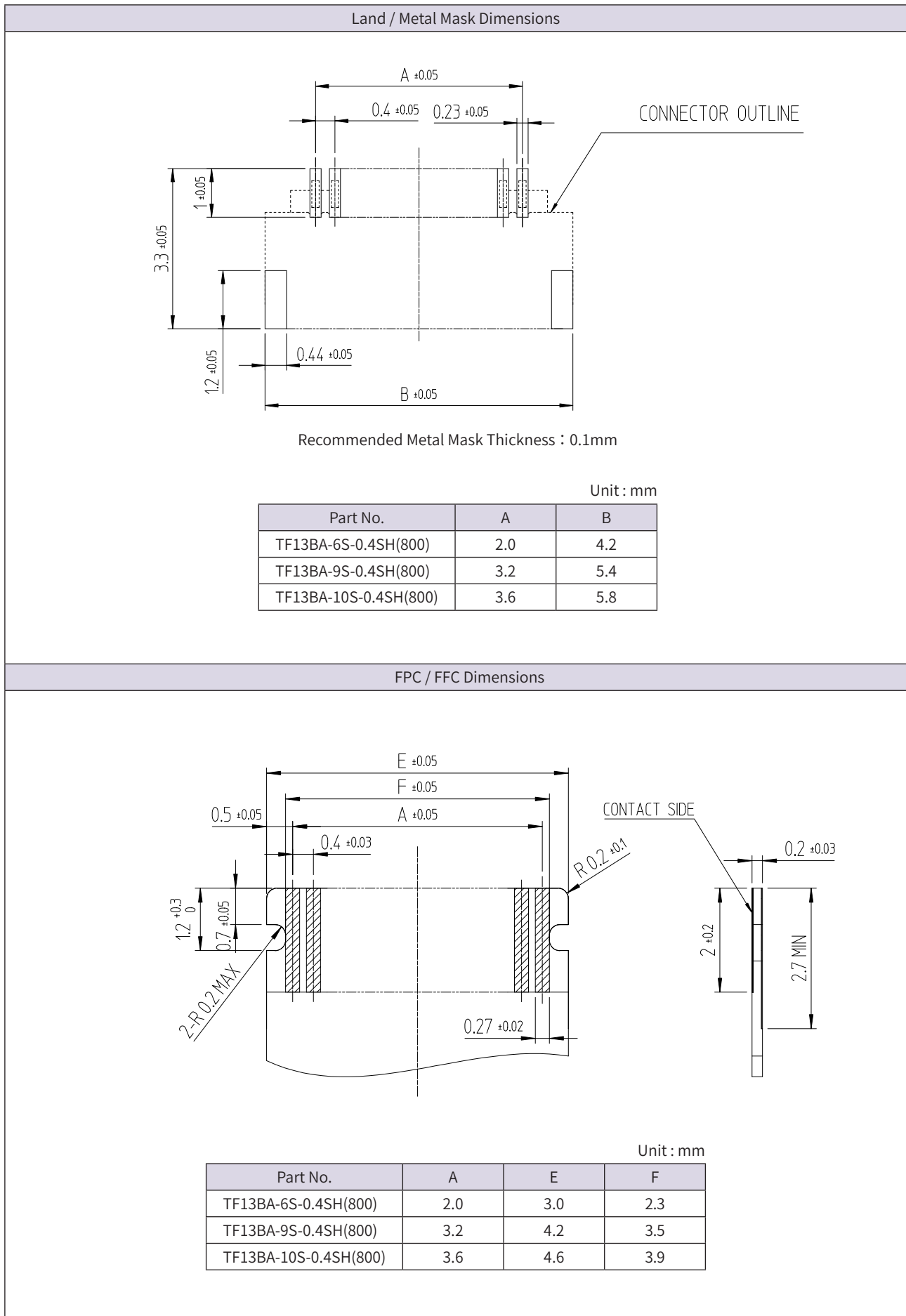

● TF13BSA Series

Land / Metal Mask Dimensions

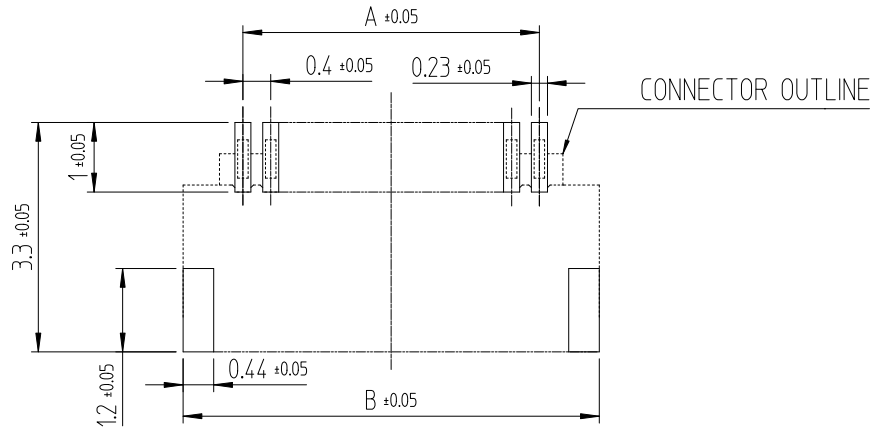

Recommended Metal Mask Thickness : 0.1mm

Unit : mm

Part No.	A	B
TF13BSA-14S-0.4SH(800)	5.2	7.0
TF13BSA-16S-0.4SH(800)	6.0	7.8
TF13BSA-18S-0.4SH(800)	6.8	8.6
TF13BSA-20S-0.4SH(800)	7.6	9.4

FPC / FFC Dimensions

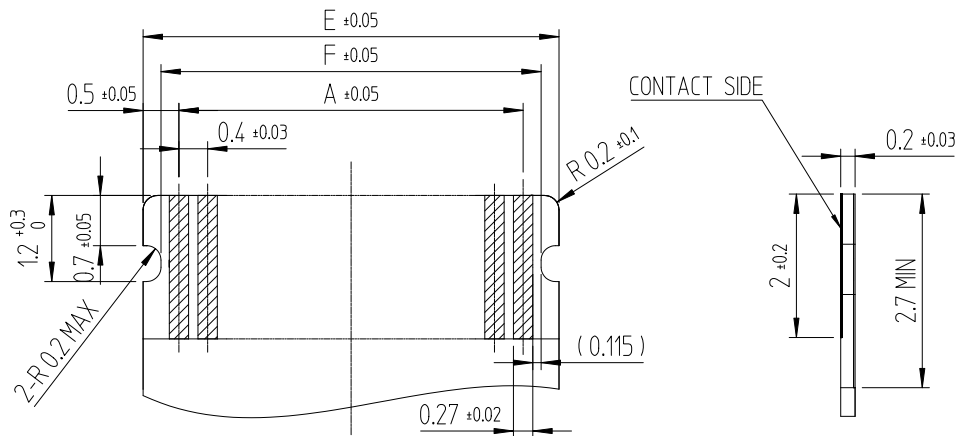

Unit : mm

Part No.	A	E	F
TF13BSA-14S-0.4SH(800)	5.2	6.2	5.7
TF13BSA-16S-0.4SH(800)	6.0	7.0	6.5
TF13BSA-18S-0.4SH(800)	6.8	7.8	7.3
TF13BSA-20S-0.4SH(800)	7.6	8.6	8.1

## ◆ Packaging Specification

### ● Embossed Carrier Tape Dimensions

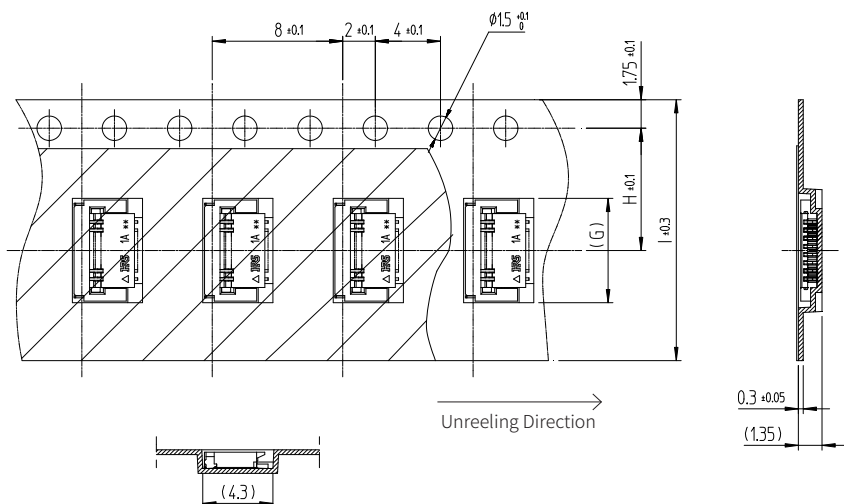

### ● Reel Dimensions

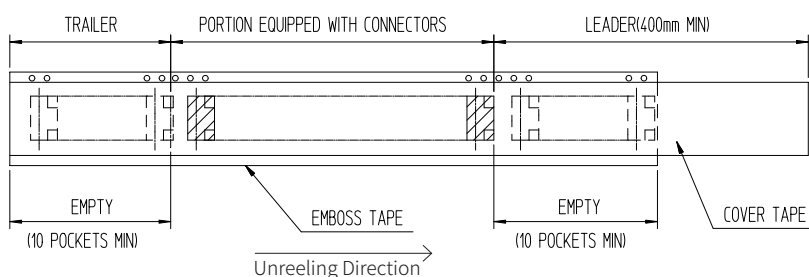
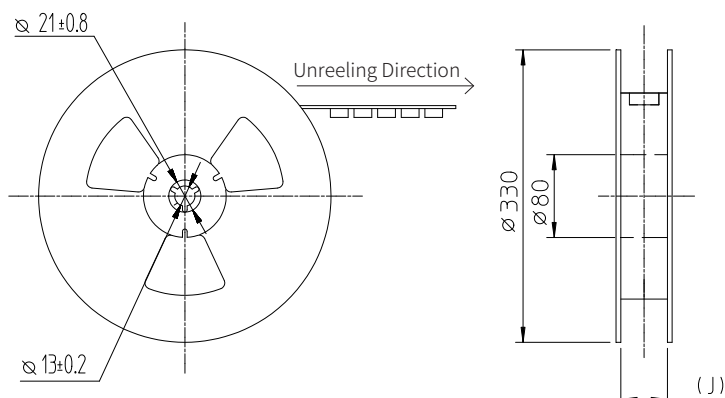

Note 1 : 5,000pcs / Reel (Outer diameter of Reel :  $\phi 330$ mm)

Note 2 : Material

- 1) Emboss tape : PS (ANTISTATIC TREATMENT)
- 2) Cover tape : PET (ANTISTATIC TREATMENT)

Unit : mm

Part No.	HRS No.	No. of Pos.	G	H	I	J
TF13BA-6S-0.4SH(800)	480-0340-0 00	6	4.4	7.5	16.0	16.5
TF13BA-9S-0.4SH(800)	480-0341-0 00	9	5.6	7.5	16.0	16.5
TF13BA-10S-0.4SH(800)	480-0495-0 00	10	6.0	7.5	16.0	16.5
TF13BSA-14S-0.4SH(800)	480-0423-0 00	14	7.2	7.5	16.0	16.5
TF13BSA-16S-0.4SH(800)	480-0342-0 00	16	8.0	11.5	24.0	24.5
TF13BSA-18S-0.4SH(800)	480-0343-0 00	18	8.8	11.5	24.0	24.5
TF13BSA-20S-0.4SH(800)	480-0344-0 00	20	9.6	11.5	24.0	24.5

## ◆ FPC/FFC Construction (Recommended Specifications)

### ● FPC : Flexible Printed Circuit

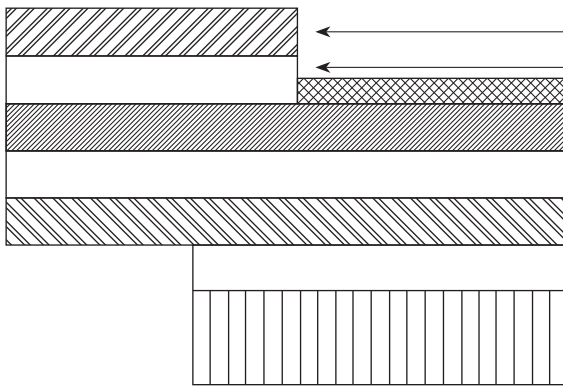

Material Name	Material	Thickness(μm)
Covering layer film	Polyimide	1mil (25)
Cover adhesive		(25)
Surface treatment	Nickel 1 to 5μm + Gold plating 0.2μm	4
Copper foil	CU	1oz (35)
Base adhesive	Thermoset adhesive	25
Base film	Polyimide	1mil (25)
Reinforcement	Thermoset adhesive	35
Material adhesive		
Stiffener	Polyimide	5mil (75)
<b>Total</b>		<b>199</b>

### ● FFC : Flexible Flat Cable

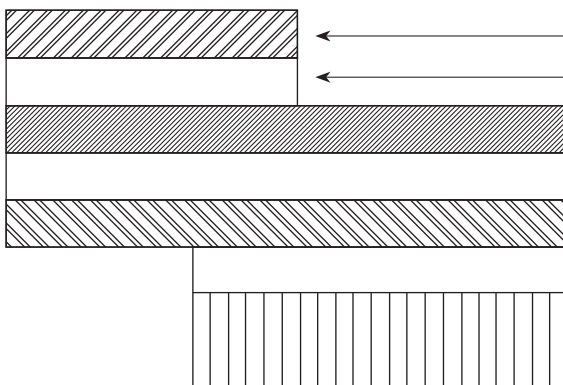

Material Name	Material	Thickness(μm)
Polyester film		(12)
Adhesive	Polyester thermoplastic type	(30)
Annealed copper foil	Gold-plated nickel	35
Adhesive	Polyester type	30
Polyester		12
Adhesive	Polyester type	30
Stiffener	Polyester type	92
<b>Total</b>		<b>199</b>

Note 1 : The material composition of FPC/FFC is for reference. Please make the thickness of the FPC/FFC mating section  $0.2 \pm 0.03\text{mm}$  in reference to the above FPC/FFC construction.

Note 2 : For details about component configuration, please contact a FPC/FFC manufacturer.

## ◆ Recommended Temperature Profile

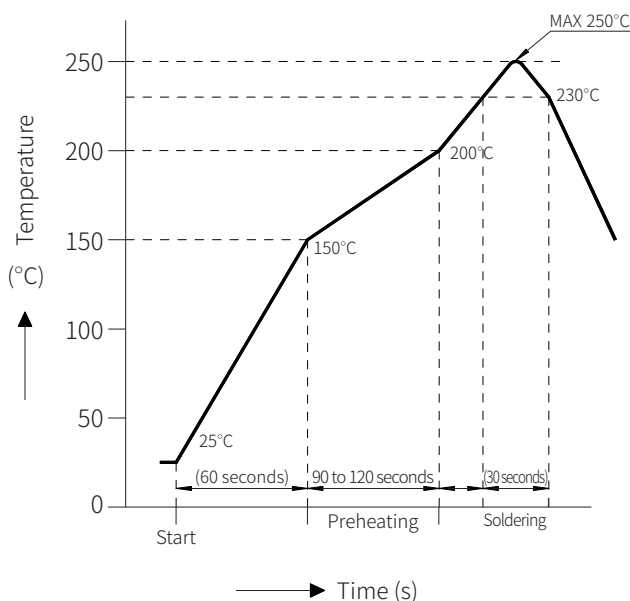

### HRS Test Conditions

Reflow Method : Reflow, IR/hot air  
 Reflow Environment : Room air  
 Solder Composition : Paste, 96.5%Sn/3%Ag/0.5%Cu (M705-221CM5-32-10.5 from Senju Metal Industry Co., Ltd.)

Test Board : Glass epoxy 50mm×25mm×1mm thick  
 Land Dimensions : Check the recommended land dimensions for details.

Metal Mask : Check the recommended metal mask dimensions for details.

The temperature profile is based on the above conditions. Please check the mounting conditions before use, conditions such as solder paste types, manufacturer, PCB size and any other soldering materials may alter the performance of such materials.

## ◆ Connector Operation and Precautions

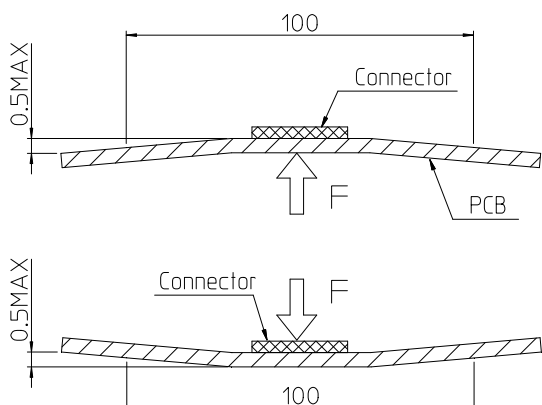
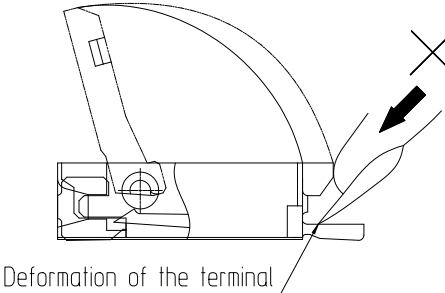
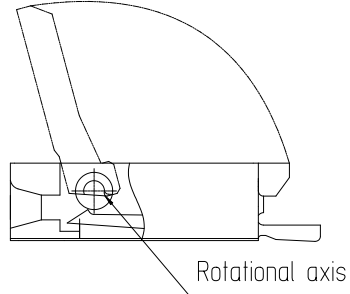
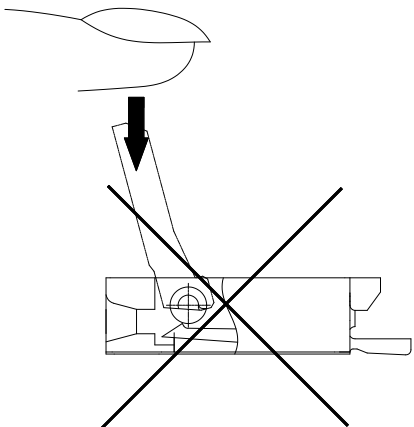
Board Mounting Precautions	FPC/FFC Insertion/Mating Precautions
<p>● <b>Board Warpage</b></p> <p>Be sure to minimize the board warpage as much as possible. The lead co-planarity is 0.1mm or less. Excessive board warpage may result in soldering failures or co-planarity issues.</p> <p>● <b>Connector Load</b></p> <p>Do not apply a force of 0.5N or more to the connector before mounting it on the board to prevent connector damage. Do not insert the FPC/FFC or operate the connector before mounting.</p> <p>● <b>Board Stress</b></p> <ul style="list-style-type: none"> <li>• Splitting a large board into several pieces</li> <li>• Screwing the board</li> </ul> <p>Avoid the handling described above so that no excessive force is exerted on the board during the assembly process. Otherwise, the connector may become defective.</p> <p>● <b>Acceptable Amount of Board Warpage</b></p> <p>A 100mm wide board has an acceptable warp range of 0.5mm or less. (Below) Excessive amounts of warping will place stress on the connector which may result in damage and malfunction.</p> 	<p>● <b>Actuator Operation</b></p> <ol style="list-style-type: none"> <li>1. Do not apply excessive force when releasing the actuator from the initial position (without FPC/FFC inserted). Inserting a nail or finger as shown in the below picture may result in terminal deformation.</li> </ol>  <ol style="list-style-type: none"> <li>2. The actuator rotates around the rotational axis as shown below. Please rotate the actuator.</li> </ol>  <ol style="list-style-type: none"> <li>3. Please do not push the actuator downwards with a force of 0.5N or more as shown below. Otherwise, the actuator may fall off or be damaged.</li> </ol> 

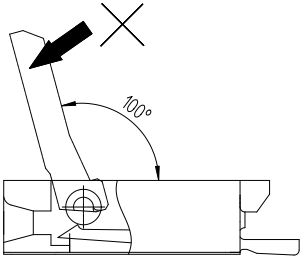
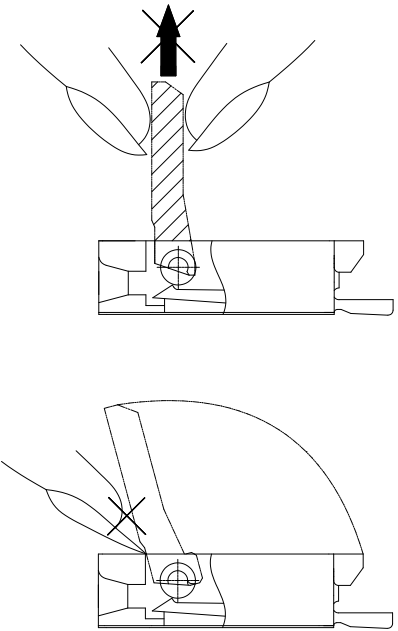
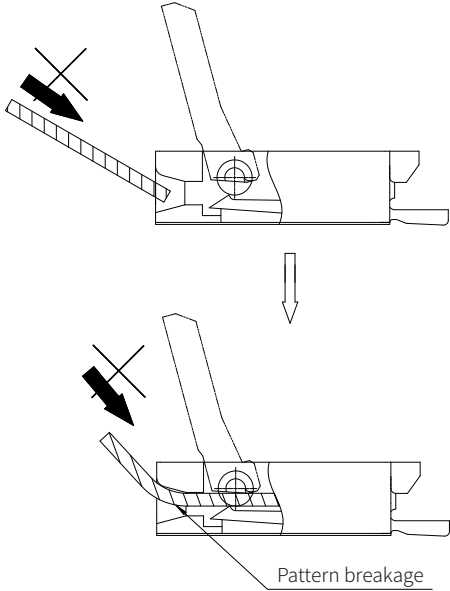
FPC/FFC Insertion/Mating Precautions	FPC/FFC Insertion/Mating Precautions
<p>4. The actuator is not designed to open more than 100°. Do not apply any force to open it beyond this point. Doing so may result in actuator damage or breakage.</p>  <p>5. Operate the actuator towards the center. It may break if operated on one side of the actuator with FPC/FFC inserted.</p> <p>6. Do not pull or pick the actuator to lift it as shown below. Failure to do so may result in connector breakage. (Do not carry out any operation other than rotating the actuator as shown in 2 on the previous page.)</p>  <p>● <b>Contact Orientation</b></p> <p>This connector utilizes bottom contacts. Insert the FPC/FFC with the exposed conductors face down.</p>	<p>● <b>Inserting the FPC/FFC</b></p> <p>1. Insert the FPC/FFC horizontally along the surface and at right angle to the connector. Insert it completely to the end. If the FPC/FFC is incorrectly inserted at a diagonal the conductors may short-circuit due to pitch shift misalignment or the edge of the FPC/FFC may catch in the terminals resulting in deformation of the terminal. This connector has a ZIF structure and its effective mating length is 1.87mm. (when the recommended FPC/FFC nominal is used) Use the actuator carefully to prevent the FPC/FFC from Shifting after insertion.</p> <p>2. Do not insert the FPC/FFC diagonally from above. If the FPC/FFC is incorrectly inserted at a diagonal as shown in the above FPC/FFC insertion process. The FPC/FFC may be bent, resulting in pattern breakage or insufficient FPC/FFC insertion which may cause conduction failure.</p>  <ul style="list-style-type: none"> <li>• Secure sufficient FPC insertion space during layout design to prevent incorrect FPC/FFC insertion. Additionally, if the FPC/FFC is too short it will make insertion difficult so please design an appropriate component layout.</li> <li>• Make adjustments with the FPC/FFC manufacturer for bending performance and breakage resistance.</li> </ul> <p>● <b>Ensuring a Completed Connection</b></p> <p>After completing the locking operation, check that the actuator is horizontal to the board surface. Do not apply excessive force when the actuator reaches 0°, doing so may damage the terminals. (Allowable force: 1N Max.)</p>

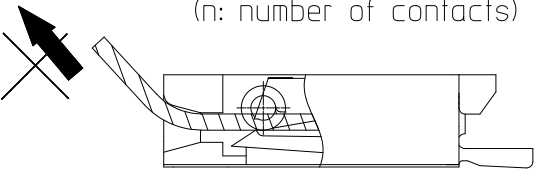
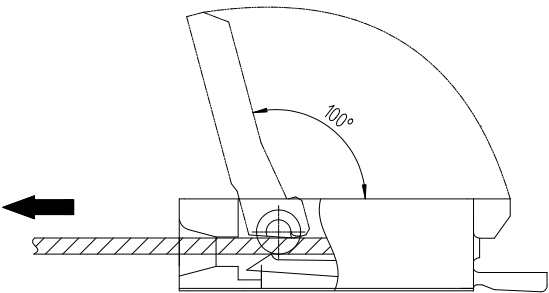
Instructions on FPC/FFC Layout after Mating	Other Precautions
<p>● <b>Load to FPC/FFC</b></p> <p>Do not apply direct force to the connector during FPC/FFC routing. Contact failure, disconnection or breakage may occur when using a FPC/FFC bent near the connector.</p> <p>In general the FPC/FFC should not be bent sharply near the insertion opening. Secure the FPC/FFC when applying a continuous load.</p> <p style="text-align: center;">Load: <math>0.03(N) \times n</math> MAX (n: number of contacts)</p> 	<p>● <b>Manual Soldering</b></p> <p>Follow the instructions listed below when soldering the connector manually during repair work, etc.</p> <ol style="list-style-type: none"> <li>1. Do not perform reflow soldering or manual soldering with the FPC/FFC inserted into the connector.</li> <li>2. Do not overheat the connector. Do not allow the soldering iron to contact any part other than the intended connector leads. Otherwise, the connector may be deformed or melted.</li> <li>3. Do not use excessive solder (or flux) If excessive solder (or flux) is used on the terminals, solder or flux may adhere to the contacts or the rotating parts of the actuator, resulting in poor contact or a rotation failure of the actuator.</li> </ol>
FPC/FFC Removal Precautions	
<p>Release the actuator near the center. The actuator may break if operated at one side with the FPC/FFC inserted.</p> <p>Remove the FPC/FFC with the actuator released.</p> 	

## ◆ While taking in consideration

Specifications mentioned in this catalog are reference values.

When considering to order or use this product, please confirm the "Drawing" and "Product Specifications" sheets.

Use an appropriate cable when using the connector in combination with cables.

If considering usage of a non-specified cable, please contact your sales representative.

If assembly process is done by jigs & tools which are not identified by Hirose assurance will not be given.

If considering usage for below mentioned applications, please contact your sales representative.

In cases where the application will demand a high level of reliability, such as automotive, medical instruments, public infrastructure, aerospace/ defense etc. Hirose must review before assurance of reliability can be given.

[ JAPAN ]

Headquarters

**HIROSE ELECTRIC CO., LTD.**

Phone : +81-45-620-7410  
<http://www.hirose.com>

[ U.S.A ]

US Headquarters / CHICAGO Office

**HIROSE ELECTRIC ( U.S.A.), INC.**

Phone : +1-630-282-6700  
<http://www.hirose.com/us/>

SAN JOSE Office

**HIROSE ELECTRIC ( U.S.A.), INC.**

Phone : +1-408-253-9640  
<http://www.hirose.com/us/>

DETROIT Office (AUTOMOTIVE)

**HIROSE ELECTRIC ( U.S.A.), INC.**

Phone : +1-734-542-9963  
<http://www.hirose.com/us/>

BOSTON Office

**HIROSE ELECTRIC ( U.S.A.), INC.**

Phone : +1-978-655-9850  
<http://www.hirose.com/us/>

DALLAS Office

**HIROSE ELECTRIC ( U.S.A.), INC.**

Phone : +1-972-324-3370  
<http://www.hirose.com/us/>

IRVINE Office

**HIROSE ELECTRIC ( U.S.A.), INC.**

Phone : +1-949-930-3750  
<http://www.hirose.com/us/>

[ THE NETHERLANDS ]

EU Headquarters / AMSTERDAM OFFICE

**HIROSE ELECTRIC EUROPE B.V.**

Phone : +31-20-6557460  
<http://www.hirose.com/eu/>

[ UNITED KINGDOM ]

UK Branch

**HIROSE ELECTRIC EUROPE B.V.**

Phone : +44-1908-202050  
<http://www.hirose.com/eu/>

[ GERMANY ]

GERMAN Branch / STUTTGART Office

**HIROSE ELECTRIC EUROPE B.V.**

Phone : +49-711-456002-1  
<http://www.hirose.com/eu/>

NUREMBERG Office

**HIROSE ELECTRIC EUROPE B.V.**

Phone : +49-911-326889-63  
<http://www.hirose.com/eu/>

HANOVER Office

**HIROSE ELECTRIC EUROPE B.V.**

Phone : +49-511-978261-30  
<http://www.hirose.com/eu/>

[ FRANCE ]

PARIS Office

**HIROSE ELECTRIC EUROPE B.V.**

Phone : +33-1-85764886  
<http://www.hirose.com/eu/>

[ ITALY ]

MILAN Office

**HIROSE ELECTRIC EUROPE B.V.**

Phone : +39-02-36636350  
<http://www.hirose.com/eu/>

[ CHINA ]

CHINA Headquarters / SHANGHAI Branch

**HIROSE ELECTRIC ( CHINA ) CO., LTD.**

Phone : +86-21-6391-3355  
<http://www.hirose.com/cn/>

SHENZHEN Branch

**HIROSE ELECTRIC ( CHINA ) CO., LTD.**

Phone : +86-755-8207-0851  
<http://www.hirose.com/cn/>

BEIJING Branch

**HIROSE ELECTRIC ( CHINA ) CO.,LTD.**

Phone : +86-10-5165-9332  
<http://www.hirose.com/cn/>

GUANGZHOU Branch

**HIROSE ELECTRIC ( CHINA ) CO.,LTD.**

Phone : +86-180-9895-1861  
<http://www.hirose.com/cn/>

[ HONG KONG ]

HONG KONG Office

**HIROSE ELECTRIC  
 HONGKONG TRADING CO., LTD.**

Phone : +852-2803-5338  
<http://www.hirose.com/hk/>

[ TAIWAN ]

TAIWAN Office

**HIROSE ELECTRIC (TAIWAN) CO., LTD.**

Phone : +886-2-2555-7377  
<http://www.hirose.com/tw/>

[ KOREA ]

KOREA Office

**HIROSE KOREA CO.,LTD.**

Phone : +82-31-496-7000  
<http://www.hirose.co.kr/>

[ SINGAPORE ]

SINGAPORE Office

**HIROSE ELECTRIC SINGAPORE PTE. LTD.**

Phone : +65-6324-6113  
<http://www.hirose.com/sg/>

[ THAILAND ]

BANGKOK Liaison Office

**HIROSE ELECTRIC SINGAPORE PTE. LTD.**

Phone : +66-2-686-1255  
<http://www.hirose.com/sg/>

[ MALAYSIA ]

PENANG Representative Office

**HIROSE ELECTRIC SINGAPORE PTE. LTD.**

Phone : +60-4-648-5536  
<http://www.hirose.com/sg/>

[ INDIA ]

BANGALORE Office

**HIROSE ELECTRIC INDIA PVT. LTD.**

Phone : +91-80-4120-1907  
<http://www.hirose.com/sg/>

DELHI Office

**HIROSE ELECTRIC INDIA PVT. LTD.**

Phone : +91-120-660-8018  
<http://www.hirose.com/sg/>

**HIROSE ELECTRIC CO.,LTD.**

2-6-3,Nakagawa Chuoh,Tsuzuki-Ku,Yokohama-Shi 224-8540,JAPAN