

TF07V Series

0.5mm Pitch, 2.1mm Height, Top & Bottom Contact, Back Flip FPC/FFC Connector

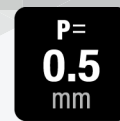

Flip-Lock Pioneer **Hirose**



P= 0.5mm



Back Flip



Top/Bottom Contact

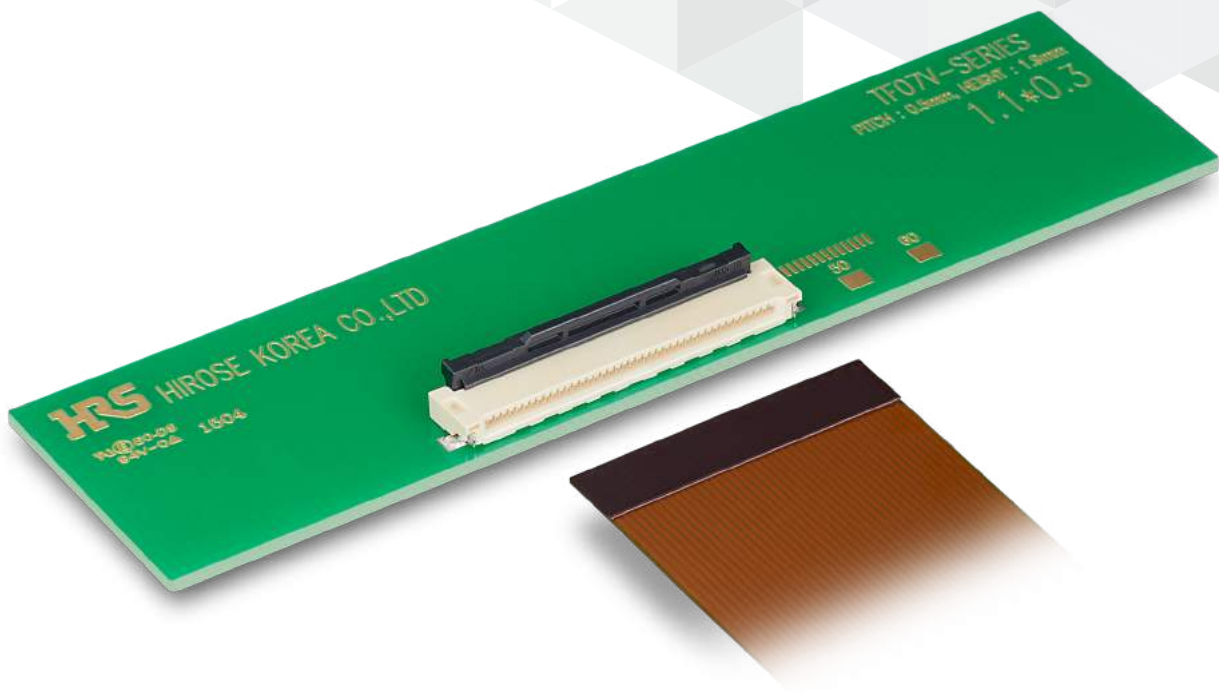

Product Page
<https://www.hirose.com/en/product/series/TF07V>

Features

1. Greater Design Flexibility

Can be used as both top and bottom contact, making it suitable for various layouts. Additionally, it is durable for both upward and downward FPC/FFC routing and offers strong FPC/FFC retention.

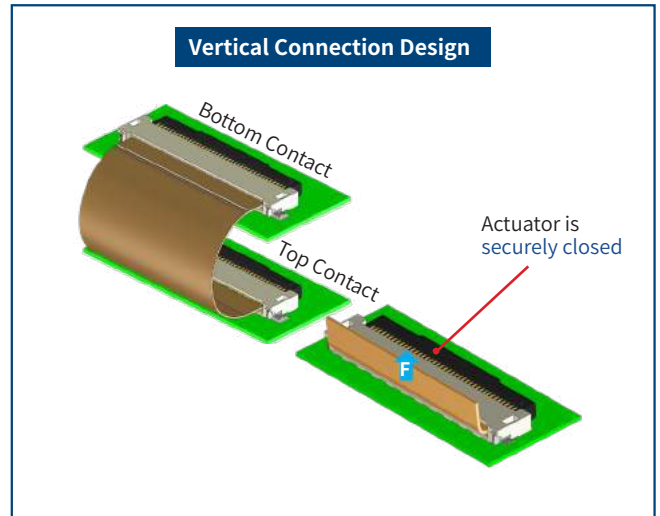

Board Design Flexibility by Top & Bottom Contact Design

2. Prevents Actuator from Coming Off

Each contact supports the actuator from the top, providing consistent support along its entire length. This design ensures the actuator remains securely attached to the housing.

3. Improved Workability

The TF07V series is delivered with the actuator already opened, simplifying the mating process into two easy steps: 1. FPC/FFC insertion, and 2. Closing the actuator. This streamlined process enhances workability.

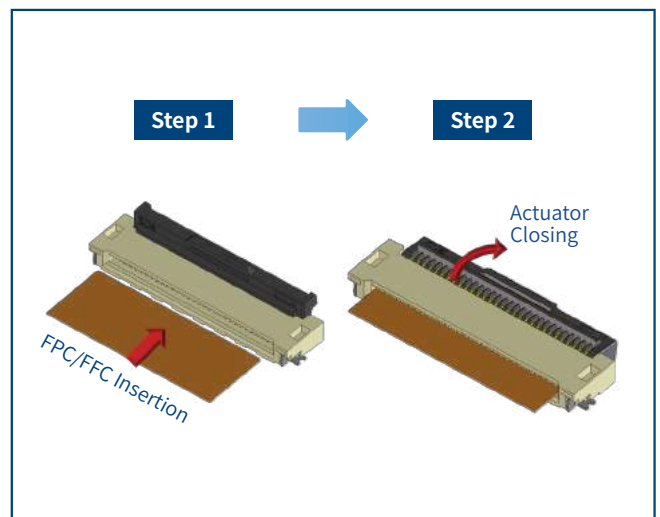

2 Simple Steps for Mating

4. User-Friendly Design

The wide taper allows easy insertion of FPC/FFC.

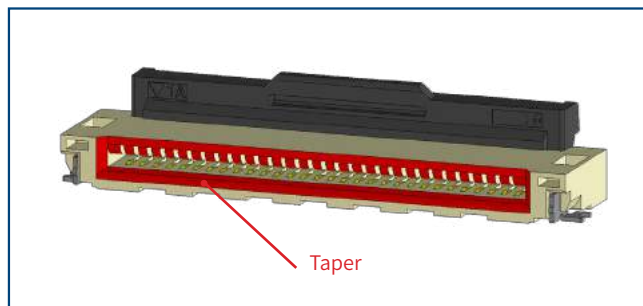

5. Halogen-Free

All materials and substances used to produce this product comply with Halogen-free standards.

*As defined in IEC 61249-2-21.
Br : 900 ppm or less, Cl : 900 ppm or less,
Br+Cl : 1,500 ppm or less.

Product Specifications

Rated Current (Note1)	0.5A	Operating Temperature (Note2)	-40 to +85° C
Rated Voltage	50V AC/DC	Operating Humidity Range	Relative Humidity 90% Max. (No condensation)
		Storage Temperature (Note3)	-10 to +50° C
		Storage Humidity Range (Note3)	Relative Humidity 90% Max. (No condensation)

Adaptive FPC/FFC Contact Specifications	Thickness : 0.3 ± 0.03mm Gold Plated Contact Traces
---	---

Items	Specifications	Conditions
Contact Resistance	50mΩ Max. *Including FPC/FFC conductor resistance	1mA (20mV AC)
Insulation Resistance	100MΩ Min.	500V DC
Withstanding Voltage	No insulation breakdown	150V AC for 1 min.
Mating Durability	Contact Resistance : 50mΩ Max. No damage, cracks, or parts dislocation.	20 cycles
Vibration Resistance	No electrical discontinuity of 1μs or more Contact Resistance : 50mΩ Max. No damage, cracks, or parts dislocation	Frequency : 10 to 55Hz, total amplitude 1.5mm for 2hours in 3 axis directions
Shock Resistance	No electrical discontinuity of 1μs or more Contact Resistance : 50mΩ Max. No damage, cracks, or parts dislocation	Acceleration : 981m/s ² , duration of pulse : 6ms Sine half-waveform, 3 cycles in each of the 3 axis.
Humidity Resistance	Contact Resistance : 50mΩ Max. Insulation Resistance : 100MΩ Min. No damage, cracks, or parts dislocation	96 hours at temperature of 40±2°C and humidity range from 90 to 95%
Temperature Cycle	Contact Resistance : 50mΩ Max. Insulation Resistance : 100MΩ Min. No damage, cracks, or parts dislocation	Temperature: -40±2 → +15 to +35 → +85±2 → +15 to +35°C Time : 30 → 2 to 3 → 30 → 2 to 3 min. 5 cycles
Solder Heat Resistance	No deformation of components affecting performance No abnormality in electrical performance	Reflow : At the recommended temperature profile

Note 1 : When passing the current through all of the contacts, use 70% of the current rating.

Note 2 : Includes temperature rise caused by current flow.

Note 3 : The term "storage" refers to products stored for long period of time prior to mounting and use.

Operating temperature range and Humidity range covers non-conducting condition of installed connectors in storage, shipment or during transportation.

Materials / Finish

Item	Material	Finish and Color	Remarks
Insulator	LCP	Beige	UL94V-0
Actuator	LCP	Black	
Contact	Phosphor Bronze	Gold plated	-
Retention Tab	Phosphor Bronze	Tin plated	

Product Number Structure

Refer to the chart below when determining the product specifications from the product number.

Please select from the product numbers listed in this catalog when placing orders.

TF07V - 40S - 0.5 SH (800)

① ② ③ ④ ⑤

① Series Name	TF07V	④ Terminal Type	SH : SMT Horizontal Mounting Type
② No. of Pos.	30, 40, 50, 60pos.	⑤ Specifications	(800): Standard, Embossed Tape Packaging (1,500pcs per reel)
③ Contact Pitch	0.5mm		

Connector Dimensions

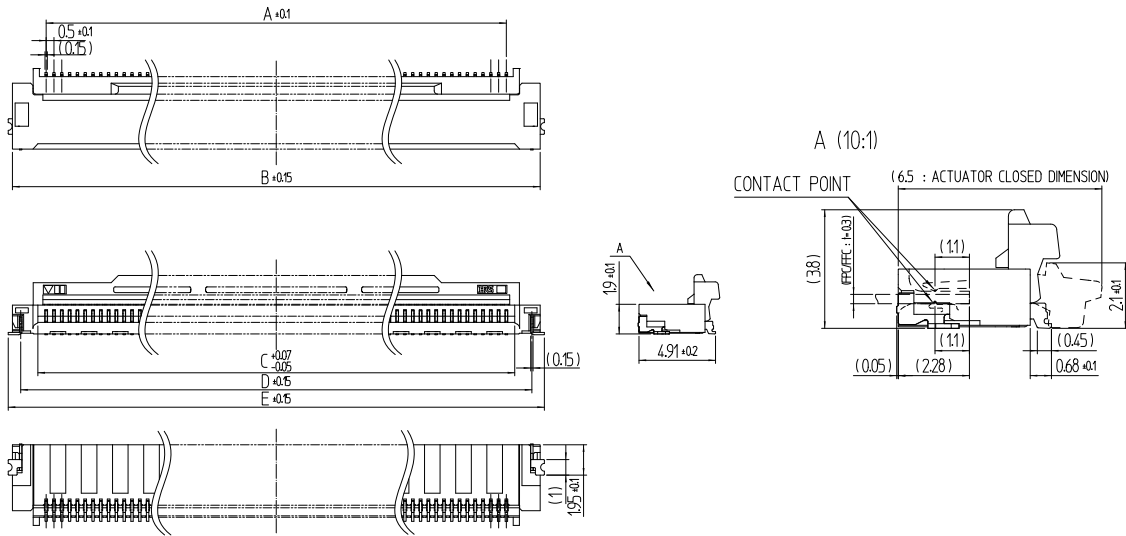

- Note 1: The coplanarity of each terminal lead is within 0.1mm.
- Note 2: This product is packaged and sold in tape and reel. Check the packaging specifications for details.
- Note 3: Sink mark reliefs may be added due to improvements.
- Note 4: Black spots may appear on the mold resin, but this does not affect product performance.
Additionally, the terminal plating may change color after reflow, however this does not represent a quality issue.

Unit : mm

Part No.	HRS No.	No. of Pos.	A	B	C	D	E	Purchase Unit
TF07V-30S-0.5SH(800)	CL0480-0540-0-00	30	14.50	18.83	15.57	17.775	19.375	1,500pcs per reel
TF07V-40S-0.5SH(800)	CL0480-0456-0-00	40	19.50	23.83	20.57	22.775	24.375	
TF07V-50S-0.5SH(800)	CL0480-0457-0-00	50	24.50	28.83	25.57	27.775	29.375	
TF07V-60S-0.5SH(800)	CL0480-0541-0-00	60	29.50	33.83	30.57	32.775	34.375	

● Recommended Land / Metal Mask Dimensions (Recommended Metal Mask Thickness:0.12mm)

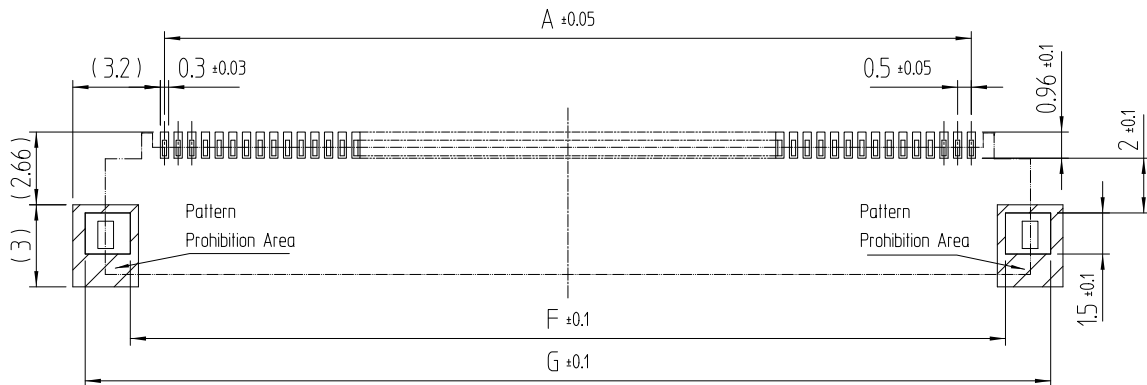

Unit : mm

Part No.	HRS No.	No. of Pos.	A	F	G
TF07V-30S-0.5SH(800)	CL0480-0540-0-00	30	14.5	17.0	20.3
TF07V-40S-0.5SH(800)	CL0480-0456-0-00	40	19.5	22.0	25.3
TF07V-50S-0.5SH(800)	CL0480-0457-0-00	50	24.5	27.0	30.3
TF07V-60S-0.5SH(800)	CL0480-0541-0-00	60	29.5	32.0	35.3

● Recommended FPC/FFC Dimensions

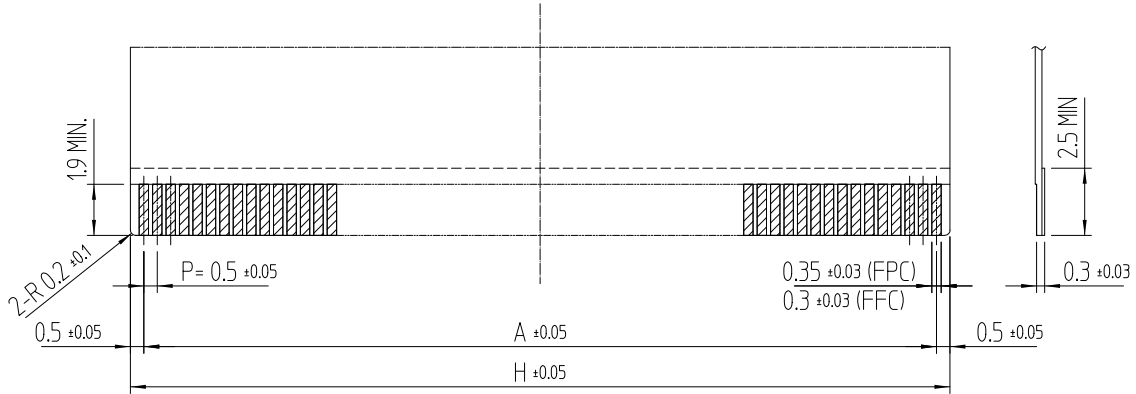

Unit : mm

Part No.	HRS No.	No. of Pos.	A	H
TF07V-30S-0.5SH(800)	CL0480-0540-0-00	30	14.5	15.5
TF07V-40S-0.5SH(800)	CL0480-0456-0-00	40	19.5	20.5
TF07V-50S-0.5SH(800)	CL0480-0457-0-00	50	24.5	25.5
TF07V-60S-0.5SH(800)	CL0480-0541-0-00	60	29.5	30.5

● FPC Construction (Recommended Specifications)

Material Name	Material	Thickness(μm)
Covering Layer Film	Polyimide 1mil	(25)
Cover Adhesive		(25)
Surface Treatment	Nickel 1 to 5μm + Gold plating	3
Copper Foil	CU 1oz	35
Base Adhesive	Thermoset adhesive	25
Base Film	Polyimide 1mil	25
Reinforcement Material Stiffener	Thermoset adhesive	30
Stiffener Film	Polyimide 2mil	175
	Total	293

● FFC Construction (Recommended Specifications)

Material Name	Material	Thickness(μm)
Polyester film		(12)
Adhesive	Polyester thermoplastic type	(30)
Annealed copper foil (Gold-plated nickel)		35
Adhesive	Polyester type	30
Polyester		12
Adhesive	Polyester type	30
Stiffener	Polyester type	188
	Total	295

Note 1: The material composition of FPC/FFC is for reference.

Please make the thickness of the FPC/FFC mating section 0.3 ± 0.03mm in reference to the above FPC/FFC construction.

Note 2: For details about component configuration, please contact a FPC/FFC manufacturer.

Packaging Specifications Diagram

● Embossed Tape Dimensions

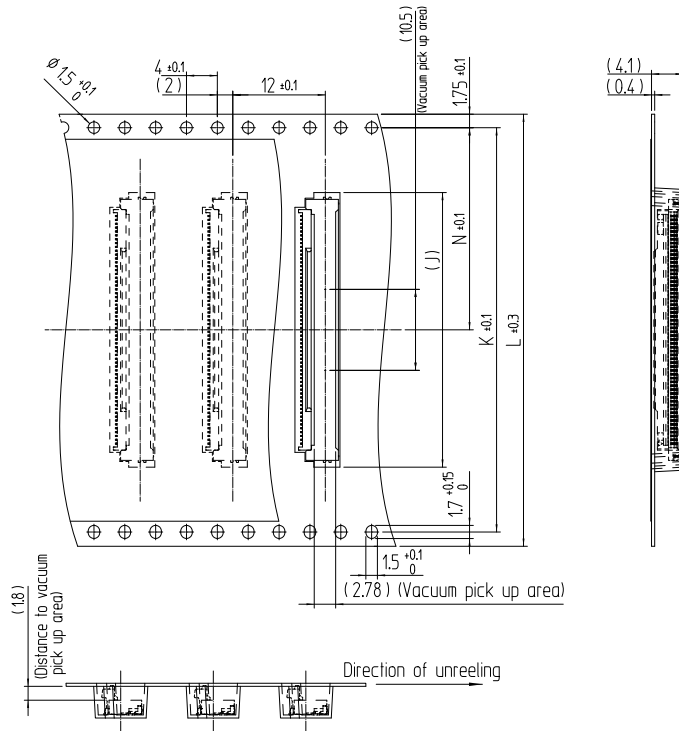

● Reel Dimensions

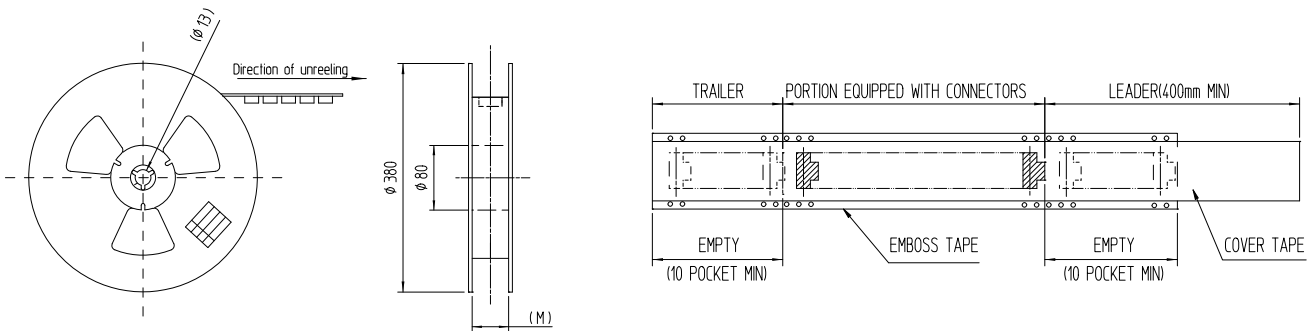

Note 1: 1,500pcs / Reel (Outer diameter of Reel ϕ 380mm)

Note 2: Material

- 1) Embossed tape : PS (Antistatic treatment)
- 2) Cover tape : PET (Antistatic treatment)

Unit : mm

Part No.	HRS No.	No. of Pos.	J	K	L	M	N
TF07V-30S-0.5SH(800)	CL0480-0540-0 00	30	20.6	28.4	32.0	32.5	14.2
TF07V-40S-0.5SH(800)	CL0480-0456-0 00	40	25.6	40.4	44.0	44.5	20.2
TF07V-50S-0.5SH(800)	CL0480-0457-0 00	50	30.6	40.4	44.0	44.5	20.2
TF07V-60S-0.5SH(800)	CL0480-0541-0 00	60	35.6	52.4	56.0	56.5	26.2

Recommended Temperature Profile

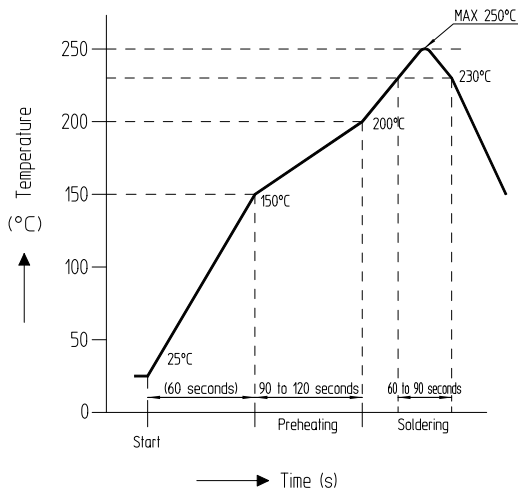

HRS Test Conditions

Reflow Method : Reflow, IR/hot air
 Reflow Environment : Room air
 Solder Composition : Paste, 96.5%Sn/3%Ag/0.5%Cu
 (M705-221CM5-32-10.5 from Senju Metal IndustryCo.,Ltd.)

Test Board : Glass epoxy 40mm × 80mm × 1.6mm thick
 Land Dimensions : Check the recommended land dimensions for details.
 Metal Mask : Check the recommended metal mask dimensions for details.

The temperature profile is based on the above conditions.
 Please check the mounting conditions before use.
 Conditions such as solder paste types, manufacturer,
 PCB size and any other solder materials may alter the
 performance of such materials.

Connector Operation and Precautions

This connector supports FPC/FFC, however, for convenience, only FPC is listed.

1. Initial condition

Actuator does not have to be operated before inserting FPC as the connector is delivered with the actuator open. [Fig. 1]

[Caution]

- Do not close the actuator before inserting FPC. Closing the actuator without FPC could make the contact gap smaller, which could increase the FPC insertion force. [Fig. 2]

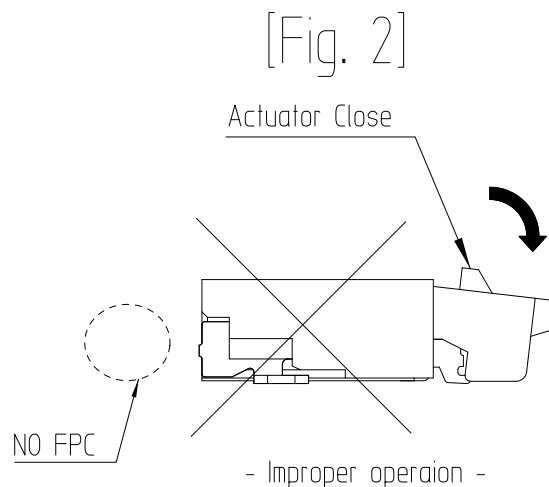
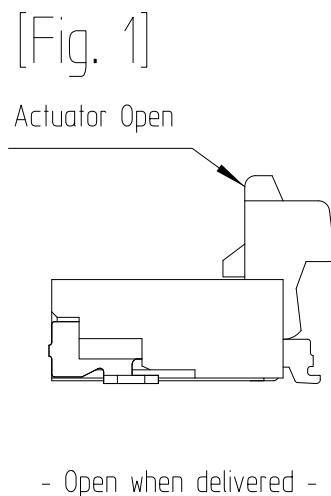

2. How to insert FPC

Horizontal Insertion: Insert the FPC into the connector opening so it aligns horizontally with the board surface. Make sure to insert it completely.

[Caution]

- Always ensure the actuator is open before inserting. [Fig. 3, Fig. 4]
- Avoid twisting the FPC up or down, right or left, or inserting it at an angle. This could damage contacts and result in connection failure.

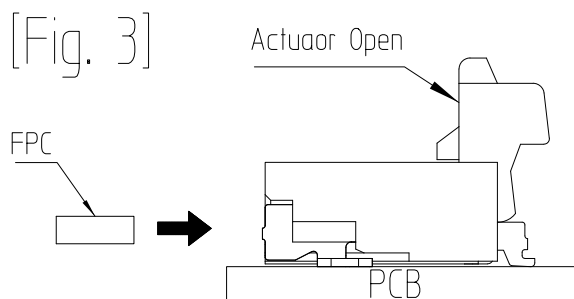

- Proper FPC insertion -

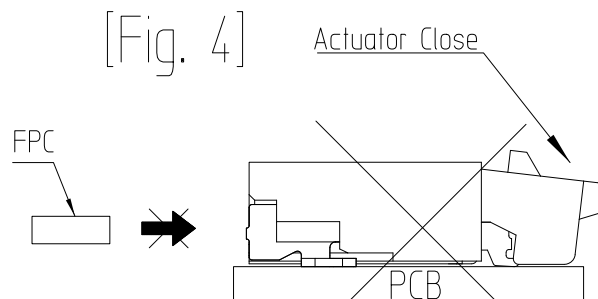

- Improper FPC insertion -

3. How to lock

After inserting the FPC, rotate the actuator as shown in [Fig. 5]

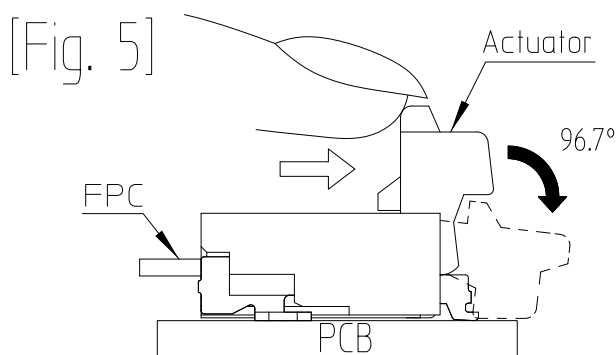

- Proper operation -

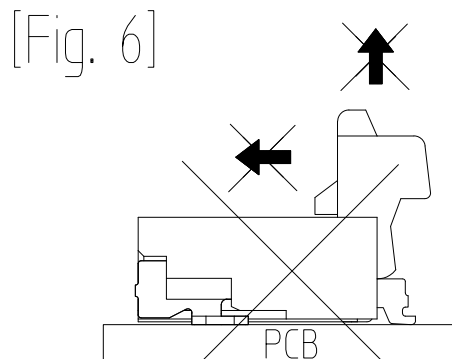

- Improper operation -

[Caution]

- The actuator rotates around its rotational axis. [Fig. 7]
- Avoid rotating the actuator in the opposite direction. Ensure you don't pull or lift the actuator. Doing so risks breaking it [Fig. 6]
- To rotate, apply force at the mid-point of the actuator [Fig. 8]. Be careful not to apply too much force during this process.

Avoid These Actions :

Do not manipulate the side end of the actuator, as this might twist it and lead to an incomplete connection.

If you cannot apply force to the middle of the actuator, please distribute the force equally to both ends and not just one end of the actuator.

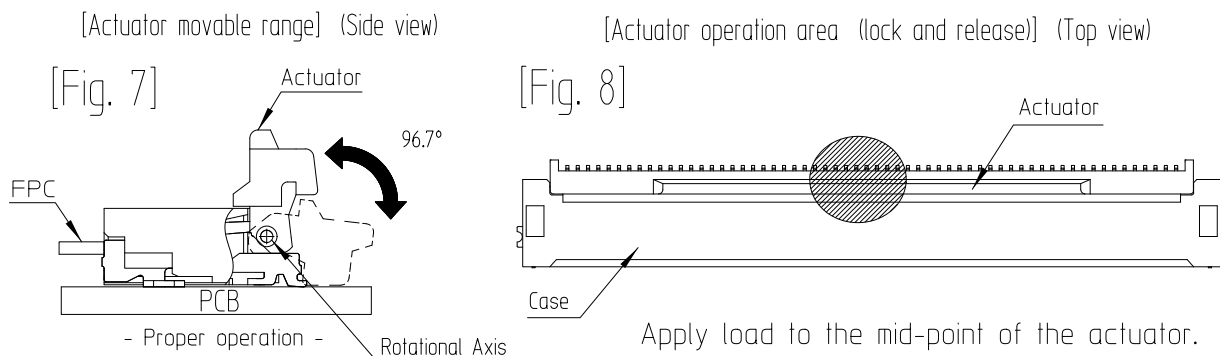
**4. How to remove FPC (Unlocking Procedure)**

Gently lift the actuator to unlock and then remove the FPC.

[Caution]

- Do not open the actuator beyond the 96.7° limit. Overextending or using excessive force might damage the actuator. [Fig. 9]
- Always use the mid-point of the actuator when opening.
- Please note that the connector is back flip type connector, and the opening for FPC insertion and the actuator face the opposite direction. Do not try to lift the actuator at the FPC insertion opening side. [Fig. 10]

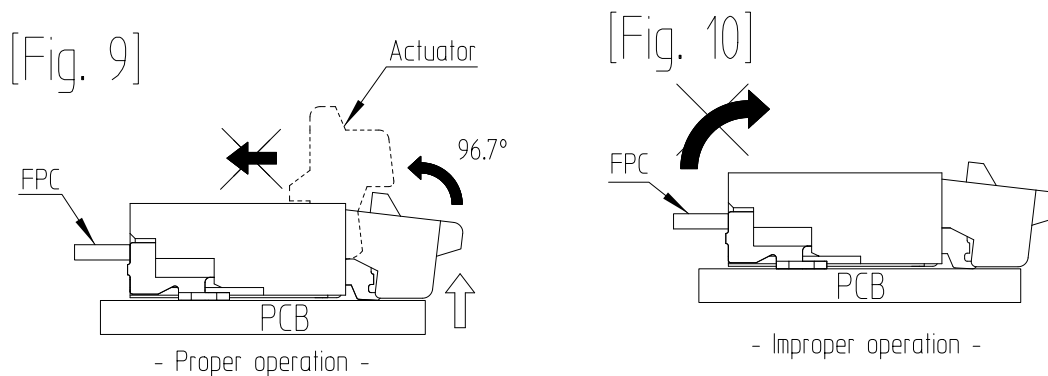
**Avoid These Actions :**

Do not lift up the side end of the actuator, or it may twist the actuator and cause breakage.

If you cannot apply force to the middle of the actuator, please distribute the force equally to both ends and not just one end of the actuator.

Avoid These Actions :

Do not remove the FPC while the actuator is still locked.

This action might damage the contacts and lead to failure.

Board Mounting Precautions

1. Board Warp Prevention

- Keep board as flat as possible.
- Lead co-planarity including reinforced retention tabs is 0.1mm or less.
- Excessive warping can lead to soldering issues.

2. Connector Load

- Do not apply a force of 0.5N or more to the connector before mounting it on the board.
- This can risk damaging the connector.
- Do not insert the FPC or operate the connector before mounting.

3. Board Load

- Be cautious when :
 - Diving a large board into smaller segments.
 - Fastening the board.
- Avoid the handling described above so that no force is applied on the board during the assembly process.
- Otherwise, the connector may be damaged.

4. Reflow Temperature Profile

- Adhere to the recommended reflow temperature conditions.
- In individual applications, the actual temperature may vary, depending on solder paste type, volume/thickness and board size/thickness.
- Consult with your solder paste and equipment manufacturer for specific recommendations.

5. Board Bend Limitation:

- For a board with a width of 100mm, its bend should not exceed 0.5mm. [Fig. 11]
- Excessive bending places strain on the connector, risking its functionality.

[Fig. 11]

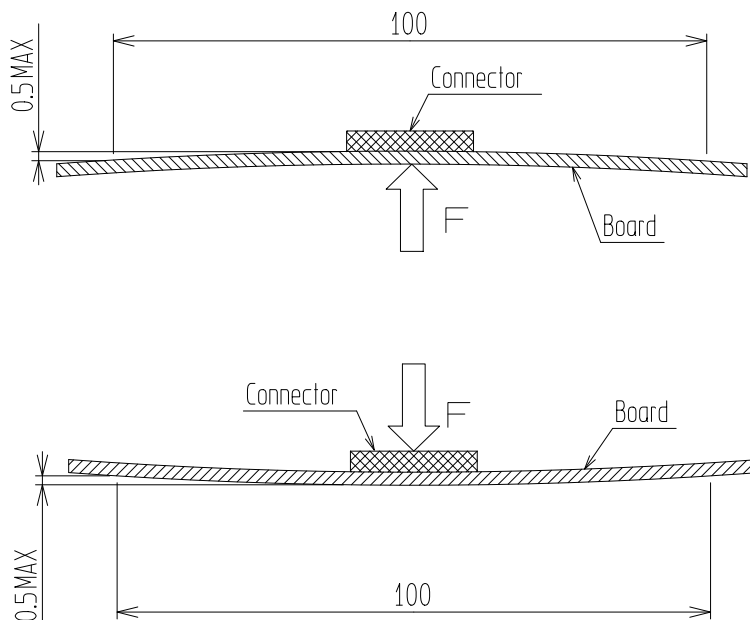

Precautions for FPC operation and layout design

This connector supports FPC/FFC, however, for convenience, only FPC is listed.

[Precautions for FPC operation and layout design]

1. During FPC wiring, ensure that stress is not applied directly to the connector.

Do not bend the FPC excessively near the connector during use, or it may cause contact failure or FPC breakage. [Fig. 12]
Stabilizing the FPC is recommended.

[Fig. 12]

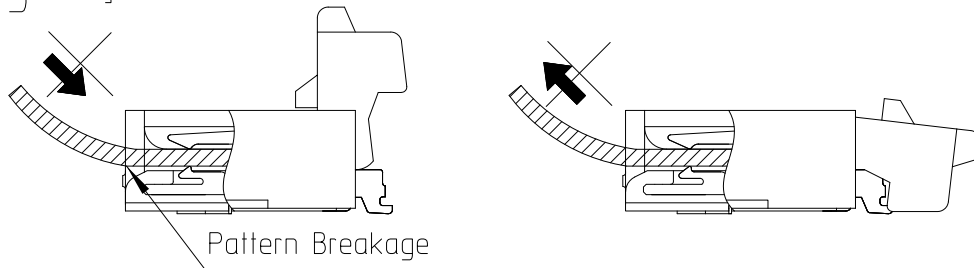

2. Ensure ample space during layout to prevent incorrect FPC insertion.

Appropriate FPC length and component layout are recommended for assembly ease.
Too short FPC length makes assembly difficult.

3. Follow the recommended PCB layout, FPC design and the metal mask opening design.

4. Confer with the FPC manufacturer to address concerns related to bending performance and potential wire breakage.

5. Ensure adequate space for the actuator's movement and operation based on the PCB needs and design.

Other precautions

This connector supports FPC/FFC, however, for convenience, only FPC is listed.

[Instructions on manual soldering]

Follow the instructions shown below when soldering the connector manually during repair work, etc.

Avoid These Actions :

1. Do not perform manual soldering with the FPC inserted into the connector.

2. Do not heat the connector excessively.

Be very careful not to let the soldering iron contact any parts other than connector leads.
Otherwise, the connector may be deformed or melt.

3. Do not apply excessive solder (or flux).

If excessive solder (or flux) is applied on the terminals, solder or flux may adhere to the contacts or rotating parts of the actuator, resulting in poor contact or a rotation failure of the actuator.
Supplying excessive solder to the retention tab may hinder actuator rotation, resulting in breakage of the connector.

While Taking into Consideration

Specifications mentioned in this catalog are reference values.

When considering to order or use this product, please review the Drawing and Product Specifications sheets.

Use an appropriate cable when using the connector in combination with cables.

If considering usage of a non-specified cable, please contact your sales representative.

If assembly process is done by jigs & tools which are not identified by Hirose, the warranty of the product may be affected.

If considering usage for below mentioned applications, please contact your sales representative.

In cases where the application will demand a high level of reliability, such as automotive, medical instruments, public infrastructure, aerospace/defense etc. Hirose must review before assurance of reliability can be given.