

Jan.1.2025 Copyright 2025 HIROSE ELECTRIC CO., LTD. All Rights Reserved.  
 use of consideration for using Automotive equipment / device which demand high reliability, kindly contact our sales window correspond

COUNT	DESCRIPTION OF REVISIONS	B	Y	CHKD	DATE	COUNT	DESCRIPTION OF REVISIONS	B	Y	CHKD	DATE
△						△					
△						△					
△						△					

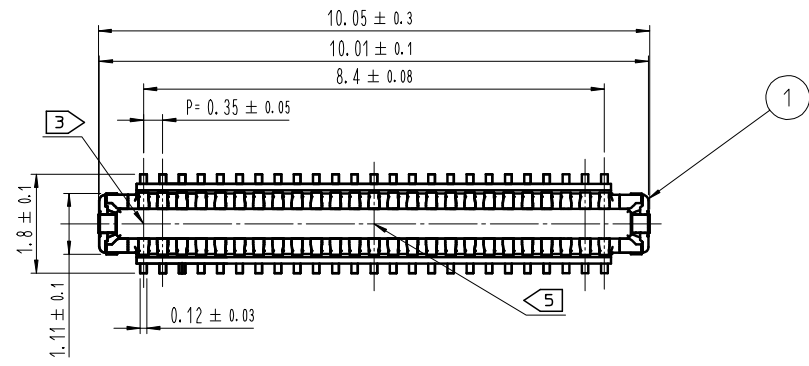

ENGAGEMENT FIGURE (50:1)

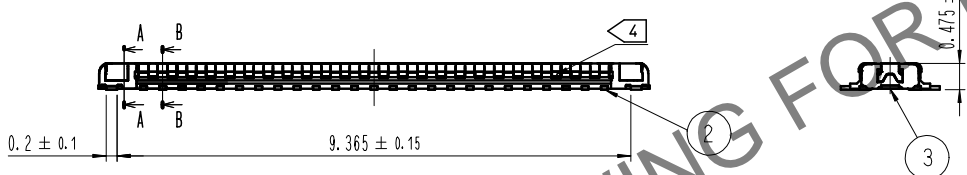
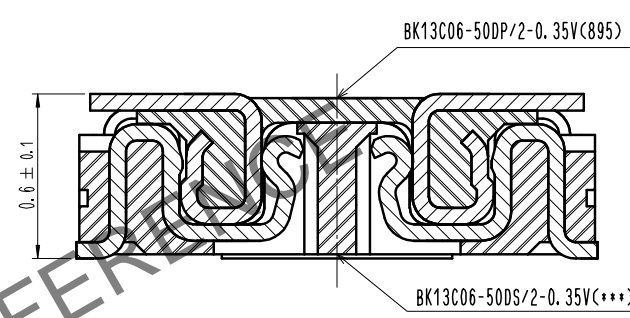

SIGNAL CONTACT

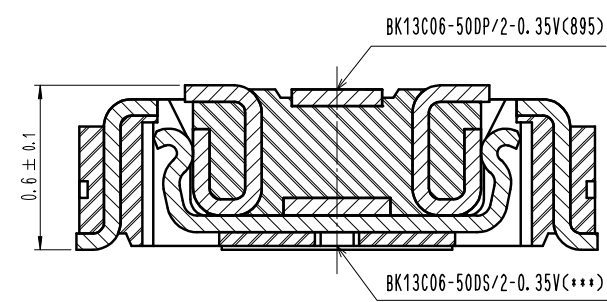

B-B (30:1)

A-A (30:1)

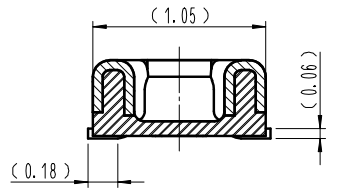
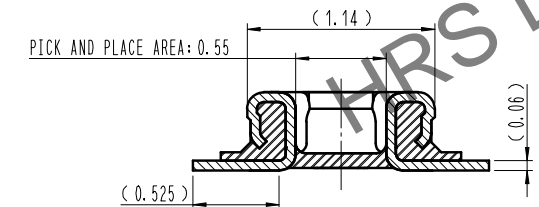

POWER CONTACT

- NOTE
1. ALL LEAD CO-PLANARITY SHALL BE 0.08mm MAX.
  2. CONTACT PLATING SPECIFICATIONS  
 CONTACT AREA : GOLD 0.05 μm MIN  
 SMT LEAD : GOLD 0.05 μm MIN  
 UNDERPLATING : NICKEL 1 μm MIN  
 (SURFACE : SEALING)
  3. CAV NO. ARE INDICATED IN APPROX POSITION SHOWN.
  4. A PART OF THE WALL COULD BE NOTCHED
  5. DENT EXISTS IN THE INDICATED AREA FOR MANUFACTURING CONVENIENCE.

4	PS	CLEAR (EMBOSSED CARRIER TAPE)			
3	COPPER ALLOY	2			
2	COPPER ALLOY	2	6	PS	BLACK (PLASTIC REEL)
1	LCP	UL94 V-0, BLACK	5	POLYESTER	CLEAR (COVER TAPE)
NO.	MATERIAL	FINISH, REMARKS	NO.	MATERIAL	FINISH, REMARKS

REMARKS			DRAWN	DESIGNED	CHECKED	APPROVED	RELEASED
			D. K. YUN	D. K. YUN	H. W. JO	H. W. JO	20.09.25
			20.09.25	20.09.25	20.09.25	20.09.25	20.09.25

CODE NO. (OLD)		DRAWING NO.	EDC3-632996-95	PART NO.	BK13C06-50DP/2-0.35V(895)
	SCALE	HIROSE KOREA CO., LTD.		CODE NO.	CL 6665-0033-4-895
	10:1				1/3
	UNITS				

Jan.1.2025 Copyright 2025 HIROSE ELECTRIC CO., LTD. All Rights Reserved.  
 use of consideration for using Automotive equipment / device which demand high reliability, kindly contact our sales window correspond

7 **RECOMMENDED PCB LAYOUT**

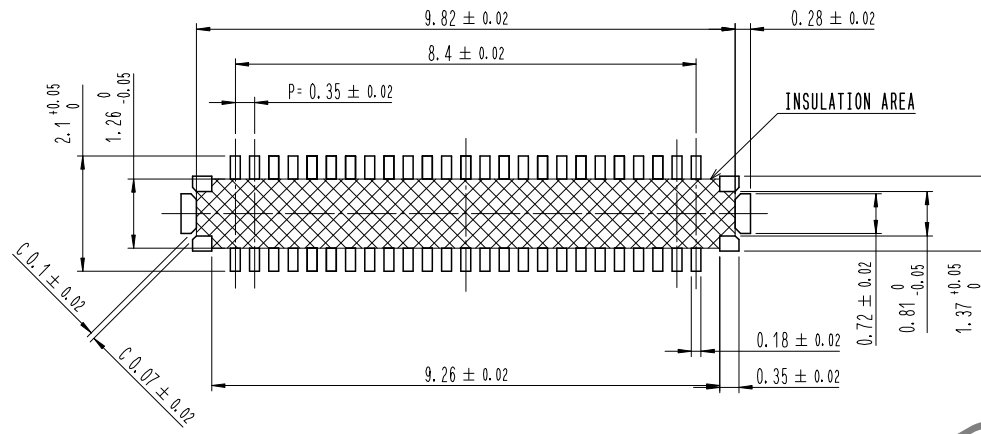

7 **RECOMMENDED METAL MASK DIMENSIONS**

METAL MASK THICKNESS : 80 μm

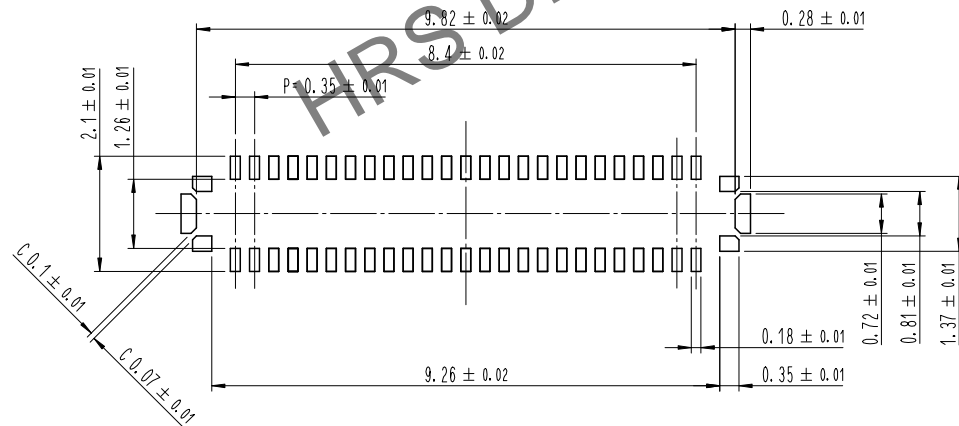

6 **RECOMMENDED REFLOW TEMPERATURE PROFILE USING LEAD-FREE SOLDER PASTE.**

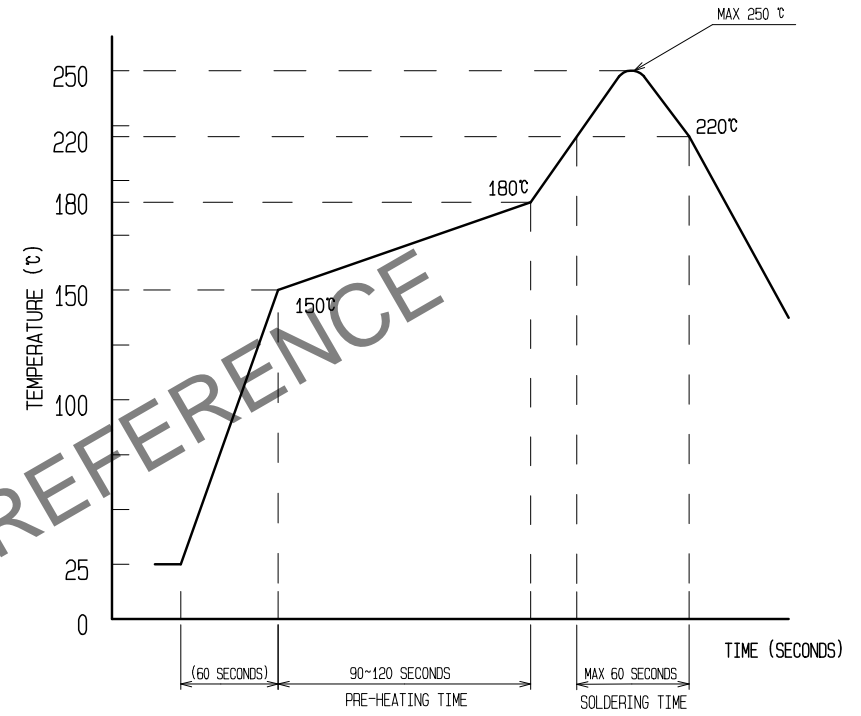

- REFLOW METHOD : N<sub>2</sub> REFLOW  
 NUMBER OF REFLOW CYCLES : 2 CYCLES MAX.  
 1) REFLOW TIME  
 DURATION ABOVE 220°C, 60 SEC MAX.  
 (PEAK TEMPERATURE : 250°C MAX)  
 2) PRE-HEAT TIME  
 PRE-HEAT TEMPERATURE(MIN): 150°C  
 PRE-HEAT TEMPERATURE(MAX): 180°C  
 PRE-HEAT TIME: 90-120 SEC.

- 6 THIS TEMPERATURE PROFILE IS PER THE CONDITIONS SHOWN ABOVE. ADDITIONAL FACTORS SUCH AS SOLDER PASTE TYPE, PCB SIZE AND OTHER MOUNTED COMPONENTS COULD AFFECT THE PROFILE. THEREFORE, A THOROUGH EVALUATION OF MOUNTING CONDITION IS REQUIRED PRIOR TO PRODUCTION. TEMPERATURE IS MEASURED AT CONTACT LEAD.  
 7 PLEASE CONTACT US IN CASE YOU WILL MAKE DIFFERENT SETTINGS FROM OUR RECOMMENDATION.  
 8 THIS PRODUCT SATISFIES HALOGEN FREE REQUIREMENTS DEFINED AS 900ppm MAXIMUM CHLORINE, 900ppm MAXIMUM BROMINE, AND 1500ppm MAXIMUM TOTAL OF CHLORINE AND BROMINE.  
 9 THIS PRODUCT COMPLY WITH RoHS.

	DRAWING NO.	EDC3-632996-95	PART NO.	BK13C06-50DP/2-0.35V(895)		
	SCALE	10:1	CODE NO	CL 6665-0033-4-895		
UNITS	HIROSE KOREA CO., LTD.			<table border="1"> <tr> <td>2</td> <td>3</td> </tr> </table>	2	3
2	3					

Jan.1.2025 Copyright 2025 HIROSE ELECTRIC CO., LTD. All Rights Reserved.  
 use of consideration for using Automotive equipment / device which demand high reliability, kindly contact our sales window correspond

# EMBOSSED CARRIER TAPE PACKAGING (5:1)

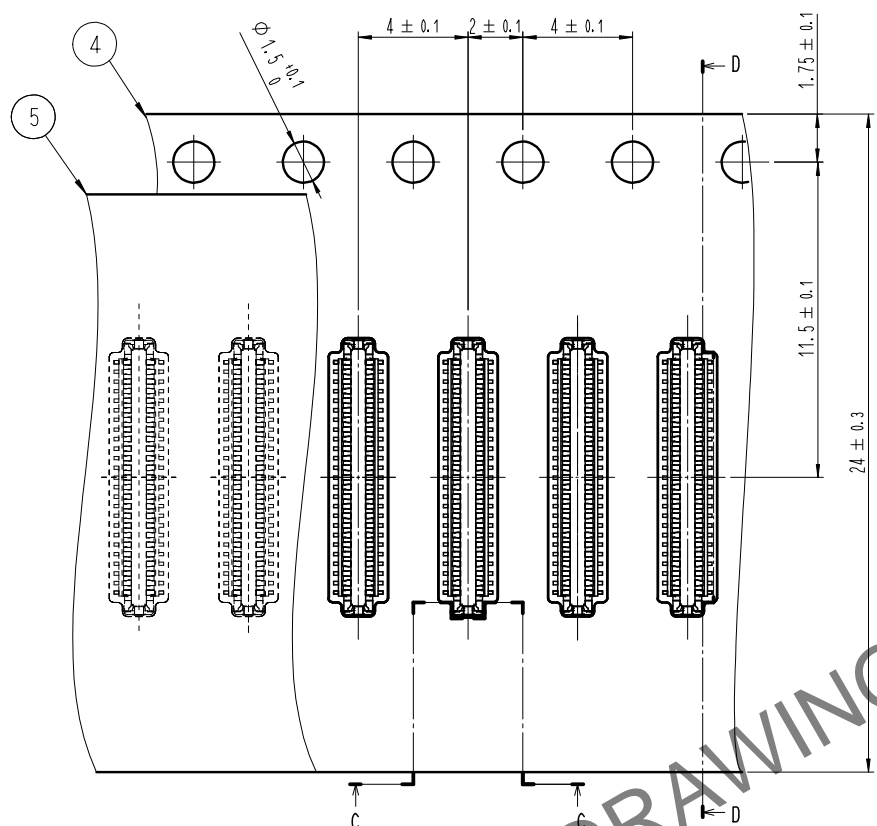

D-D (5:1)

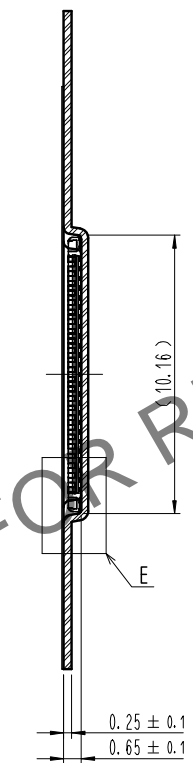

E-E (10:1)

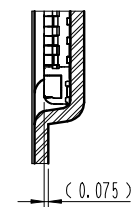

## STYLE AND DIMENSION OF REEL (FREE)

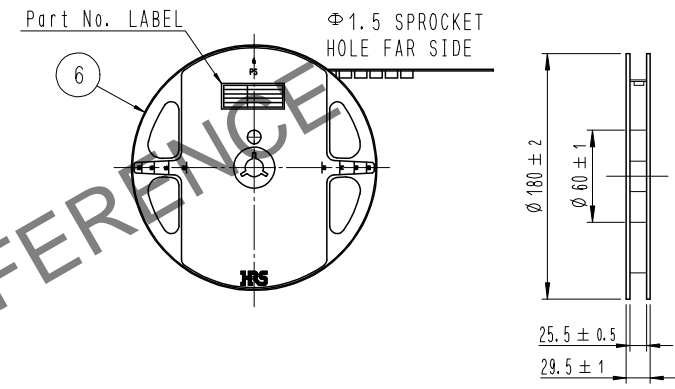

### DETAIL OF PART NO. LABEL

SUPPLIER	HIROSE ELECTRIC CO., LTD.
QUANTITY	1,000
PART NO.	BK13C06-50DP/2-0.35V(895)
CODE NO.	CL 6665-0033-4-895
DATE OF MANUFACTURED	年 月 日
生産月日	年 月 日
図番	** ** *
品名	BK13C06-50DP/2-0.35V(895)
納入数量	1,000個
納入者	HIROSE KOREA

DIRECTION OF UNREELING

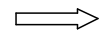

C-C (5:1)

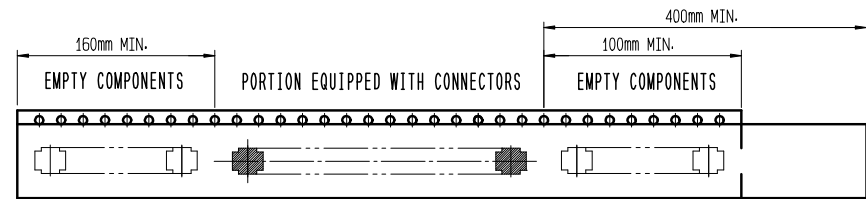
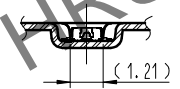

TAPING(FREE)

- 10 . PER REEL 1,000 CONNECTORS.
- 11 . THE DIMENSIONS IN PARENTHESES ARE FOR REFERENCE.
- 12 > REFER TO JIS C 0806, IEC-60286-3 (PACKAGING OF COMPONENTS FOR AUTOMATIC HANDLING)

DRAWING NO. SCALE UNITS	EDC3-632996-95	PART NO. BK13C06-50DP/2-0.35V(895)	CODE NO. CL 6665-0033-4-895
	HRS HIROSE KOREA CO., LTD.		

3/3