

Apr.1.2024 Copyright 2024 HIROSE ELECTRIC CO., LTD. All Rights Reserved.
In case of consideration for using Automotive equipment / device which demand high reliability, kindly contact our sales window correspondents.

COUNT	DESCRIPTION OF REVISIONS	B	Y	CHKD	DATE	COUNT	DESCRIPTION OF REVISIONS	B	Y	CHKD	DATE
△ 1	RE-6-3439			JDW	JHW	24.01.18					
△											
△											

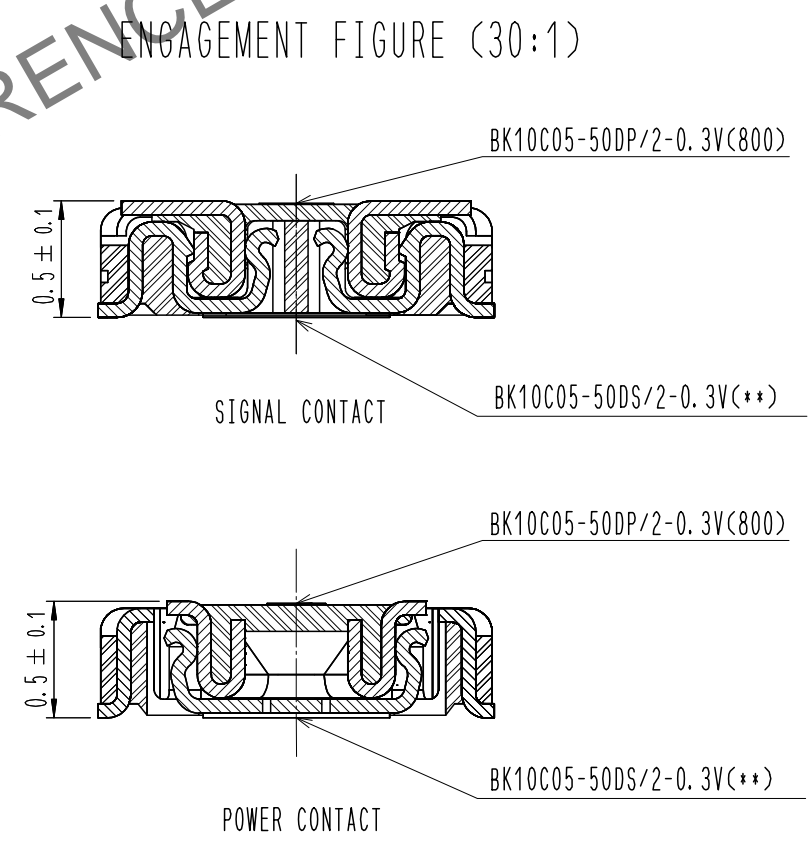
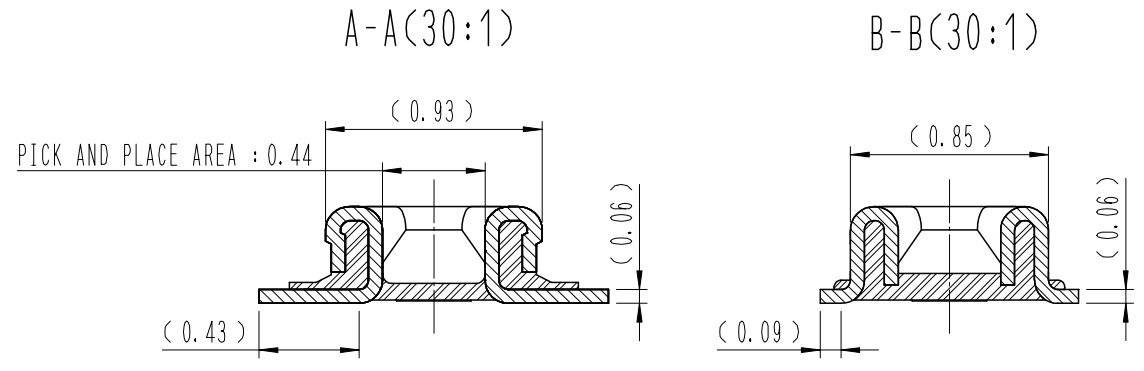
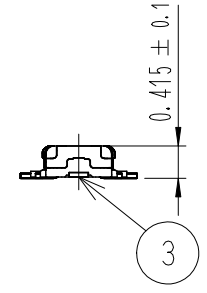
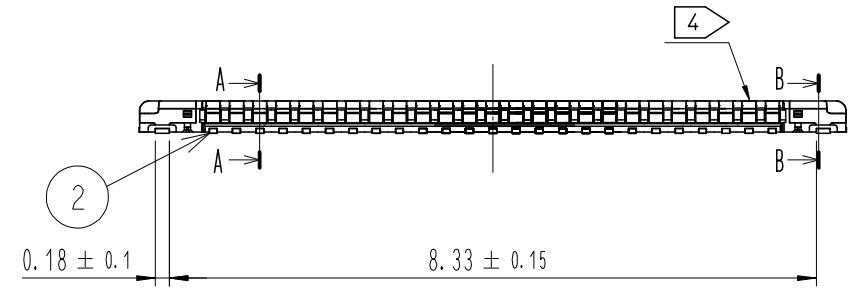
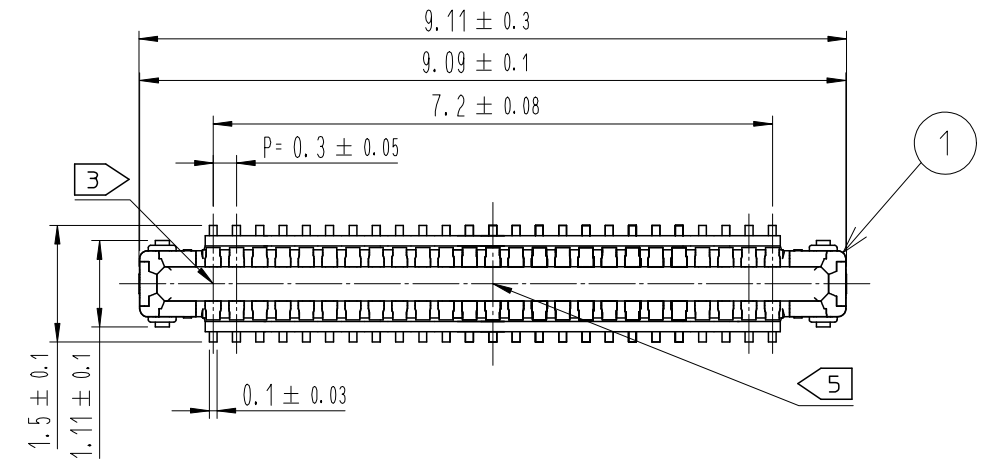

DRAWING FOR REFERENCE
This is subject to change without notice

- NOTE
- 1. ALL LEAD CO-PLANARITY SHALL BE 0.08mm MAX.
 - △ 2. CONTACT PLATING SPECIFICATIONS
CONTACT AREA : GOLD 0.05 μm MIN
SMT LEAD : GOLD 0.05 μm MIN
(NO GOLD PLATING IS ACCEPTABLE EXCEPT CONTACT POINTS AND SMT LEADS)
UNDERPLATING : NICKEL 1 μm MIN
(SURFACE : SEALING)
 - 3. CAV NO. ARE INDICATED IN APPROX POSITION SHOWN.
 - 4. A PART OF THE WALL COULD BE NOTCHED
 - 5. DENT EXISTS IN THE INDICATED AREA FOR MANUFACTURING CONVENIENCE.

4	PS	CLEAR (EMBOSSED CARRIER TAPE)			
3	COPPER ALLOY	2			
2	COPPER ALLOY	2	6	PS	BLACK (PLASTIC REEL)
1	LCP	UL94 V-0, BLACK	5	POLYESTER	CLEAR (COVER TAPE)
NO.	MATERIAL	FINISH, REMARKS	NO.	MATERIAL	FINISH, REMARKS
REMARKS			DRAWN	DESIGNED	CHECKED
			S. H. PARK	S. H. PARK	Y. J. LEE
			22.11.30	22.11.30	22.11.30
			APPROVED	RELEASED	
			H. W. JO		22.11.30
CODE NO. (OLD)	DRAWING NO. EDC3-633583-80		PART NO. BK10C05-50DP/2-0.3V(800)		
SCALE 10:1	UNITS mm		CODE NO. CL 6666-0063-1-800		1/3
		HRS HIROSE KOREA CO., LTD.			

Apr.1.2024 Copyright 2024 HIROSE ELECTRIC CO., LTD. All Rights Reserved.
In case of consideration for using Automotive equipment / device which demand high reliability, kindly contact our sales window correspondents.

7 RECOMMENDED PCB LAYOUT

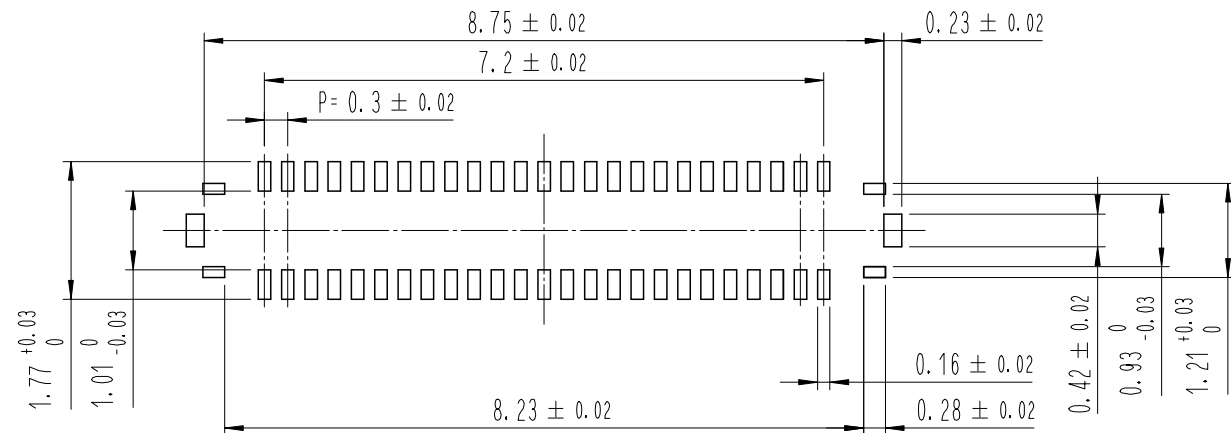

RECOMMENDED METAL MASK DIMENSIONS

MATAL MASK THICKNESS : 80 μm

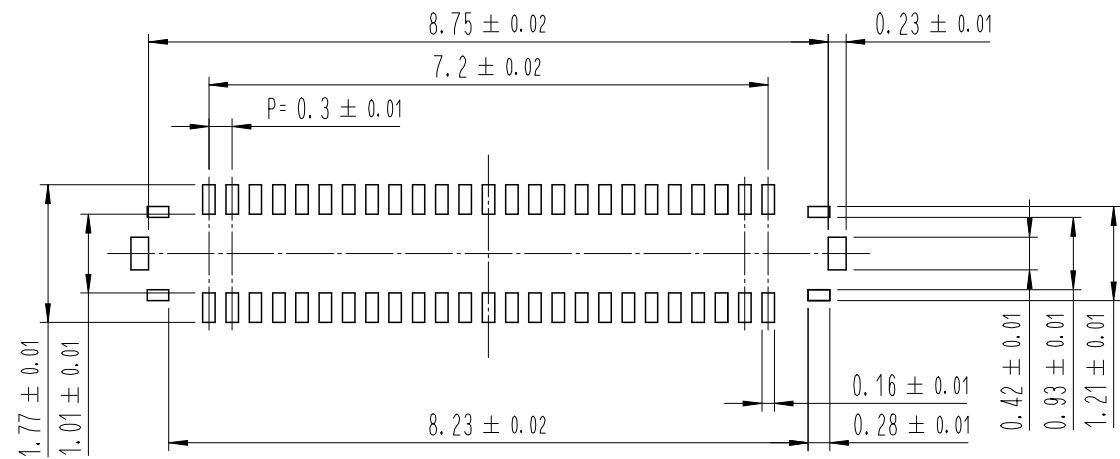

6 RECOMMENDED REFLOW TEMPERATURE PROFILE USING LEAD-FREE SOLDER PASTE.

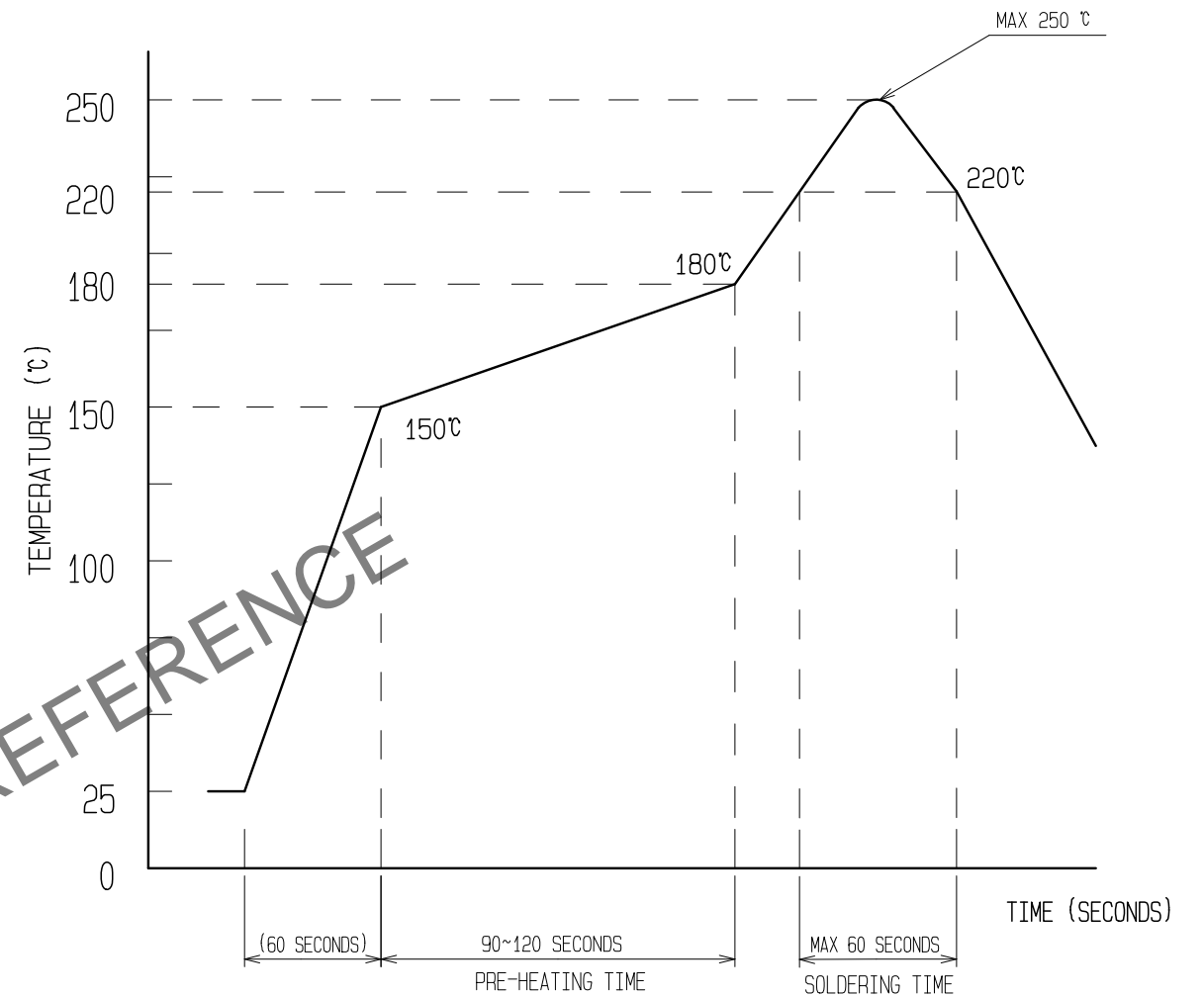

REFLOW METHOD : N₂ REFLOW
 NUMBER OF REFLOW CYCLES : 2 CYCLES MAX.
 1) REFLOW TIME
 DURATION ABOVE 220°C, 60 SEC MAX.
 (PEAK TEMPERATURE : 250°C MAX)
 2) PRE-HEAT TIME
 PRE-HEAT TEMPERATURE(MIN): 150°C
 PRE-HEAT TEMPERATURE(MAX): 180°C
 PRE-HEAT TIME: 90-120 SEC.

- 6 THIS TEMPERATURE PROFILE IS PER THE CONDITIONS SHOWN ABOVE. ADDITIONAL FACTORS SUCH AS SOLDER PASTE TYPE, PCB SIZE AND OTHER MOUNTED COMPONENTS COULD AFFECT THE PROFILE. THEREFORE, A THOROUGH EVALUATION OF MOUNTING CONDITION IS REQUIRED PRIOR TO PRODUCTION. TEMPERATURE IS MEASURED AT CONTACT LEAD.
- 7 PLEASE CONTACT US IN CASE YOU WILL MAKE DIFFERENT SETTINGS FROM OUR RECOMMENDATION.
- 8 THIS PRODUCT SATISFIES HALOGEN FREE REQUIREMENTS DEFINED AS 900ppm MAXIMUM CHLORINE, 900ppm MAXIMUM BROMINE, AND 1500ppm MAXIMUM TOTAL OF CHLORINE AND BROMINE.
- 9 THIS PRODUCT COMPLY WITH RoHS.

	DRAWING NO.	EDC3-633583-80	PART NO.	BK10C05-50DP/2-0.3V(800)
	SCALE	10:1	CODE NO	CL 6666-0063-1-800
UNITS	HRS HIROSE KOREA CO., LTD.			2/3

EMBOSSED CARRIER TAPE PACKAGING (5:1)

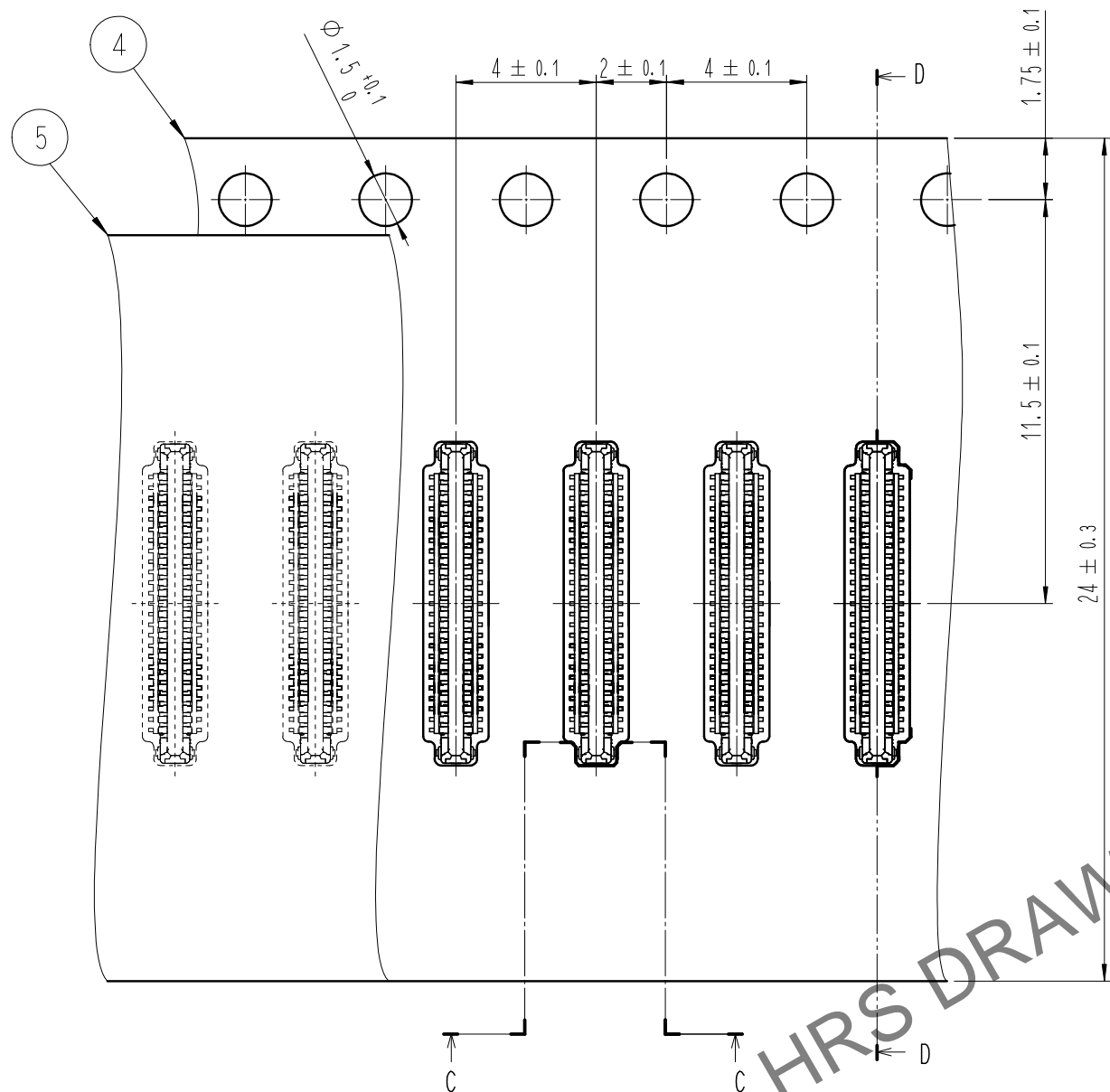

D-D (5:1)

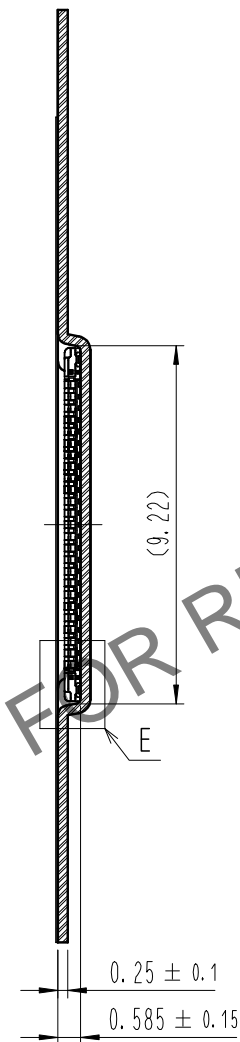

C-C (5:1)

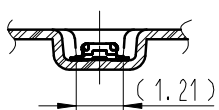

DIRECTION OF UNREELING

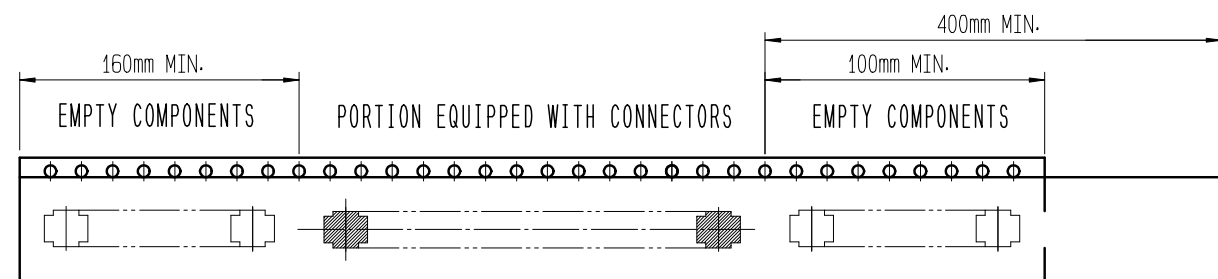
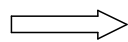

TAPING(FREE)

STYLE AND DIMENSION OF REEL (FREE)

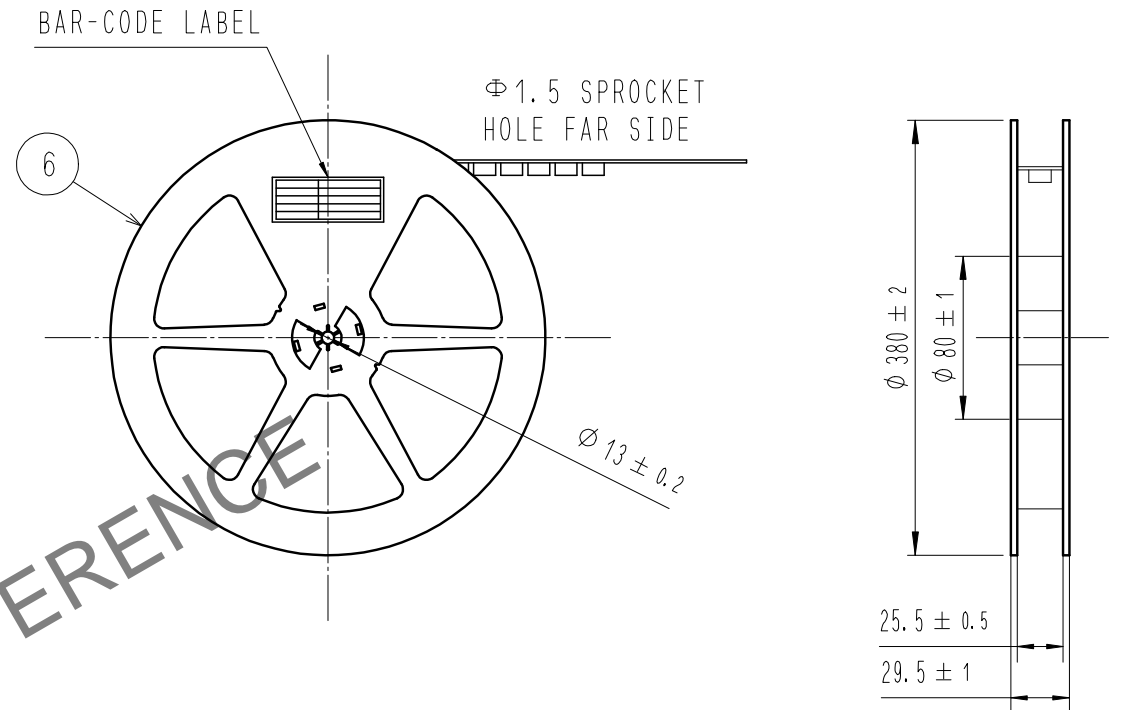

E (10:1)

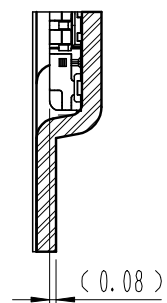

DETAIL OF PART NO. LABEL

SUPPLIER	
QUANTITY	
PART NO.	
CODE NO.	
DATE OF MANUFACTURED	
生産月日	年 月 日
図番	** ** *
品名	BK10C05-50DP/2-0.3V(800)
納入数量	20,000個
納入者	HIROSE KOREA

10 . PER REEL 20,000 CONNECTORS.

11 . THE DIMENSIONS IN PARENTHESES ARE FOR REFERENCE.

12 REFER TO JIS C 0806, IEC-60286-3 (PACKAGING OF COMPONENTS FOR AUTOMATIC HANDLING)

DRAWING NO. SCALE UNITS	EDC3-633583-80	PART NO. CODE NO.	BK10C05-50DP/2-0.3V(800)	3 3
	10:1		CL 6666-0063-1-800	
HRS HIROSE KOREA CO., LTD.				

In case of consideration for using Automotive equipment / device which demand high reliability, kindly contact our sales window correspondents.

Apr.1.2024 Copyright 2024 HIROSE ELECTRIC CO., LTD. All Rights Reserved.