

## BK10 Series

# 0.3mm Pitch, 0.5mm Stacking Height, Fully Armored, Hybrid FPC-to-Board Connector

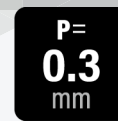

P= 0.3mm



Ultra Low Profile



Full Armored

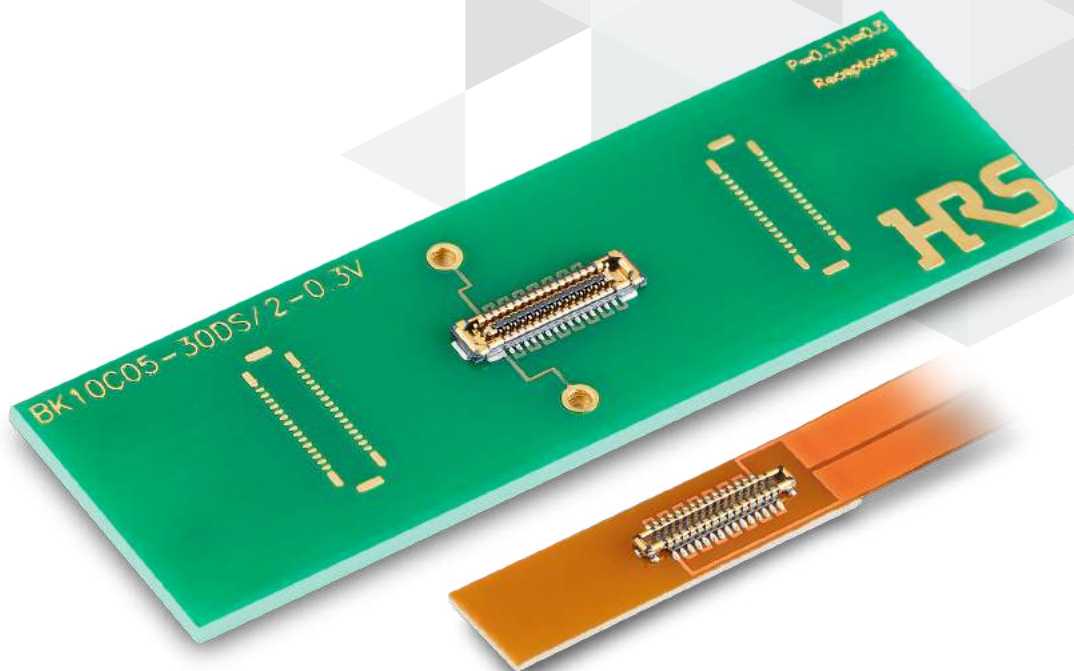

Product Page  
<https://www.hirose.com/en/product/series/BK10>

# Features

## 1. Ultra Low-profile and Space-saving Design

Compact design ideal for mobile devices.  
 • Stacking height : 0.5mm, Pitch : 0.3mm,  
 Depth : 1.7mm

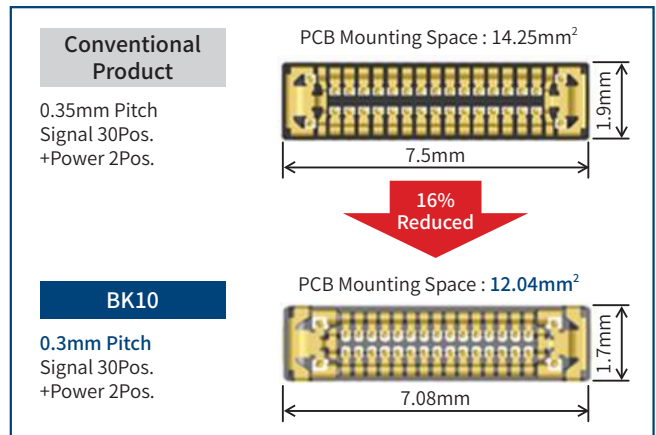
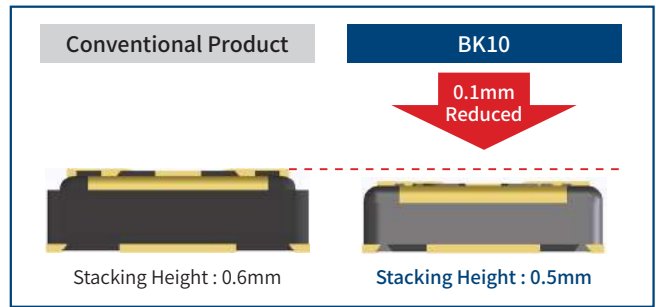

### Ultra Low-profile and Space-saving Design

## 2. Robust Design

Fully armored guides prevent housing damage due to misalignment when mating.

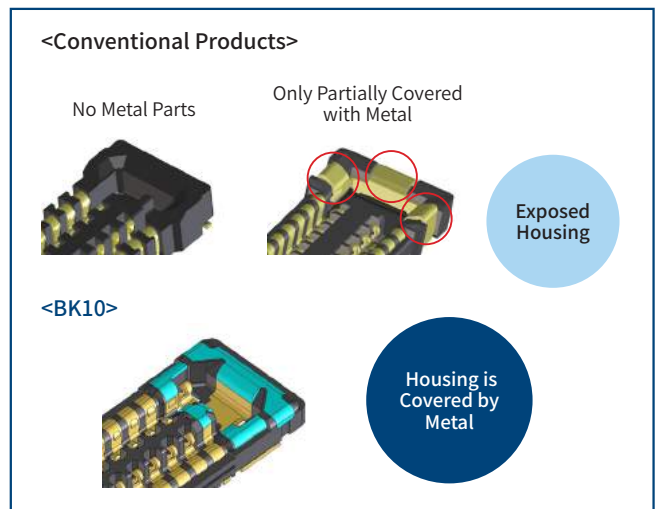

### Fully Armored Design

## 3. Dimpled Contact Lock Design for High Extraction Force

Dimpled lock design on power and signal contacts enables high extraction force.

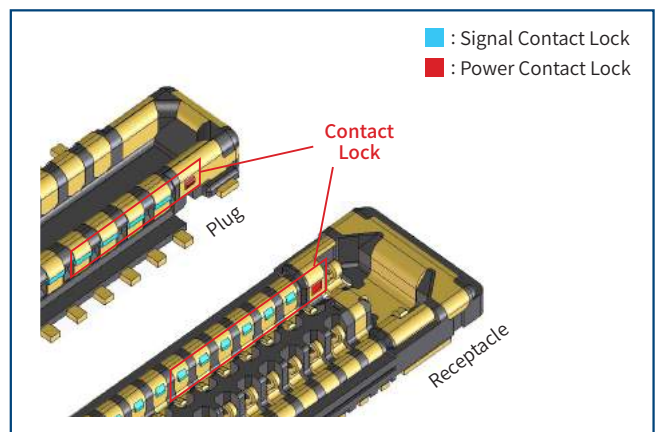

### Contact Lock Design

## 4. Enhanced PCB Peeling Strength

Both the plug and receptacle have 3 solder areas at each power contact for greater PCB peeling strength.

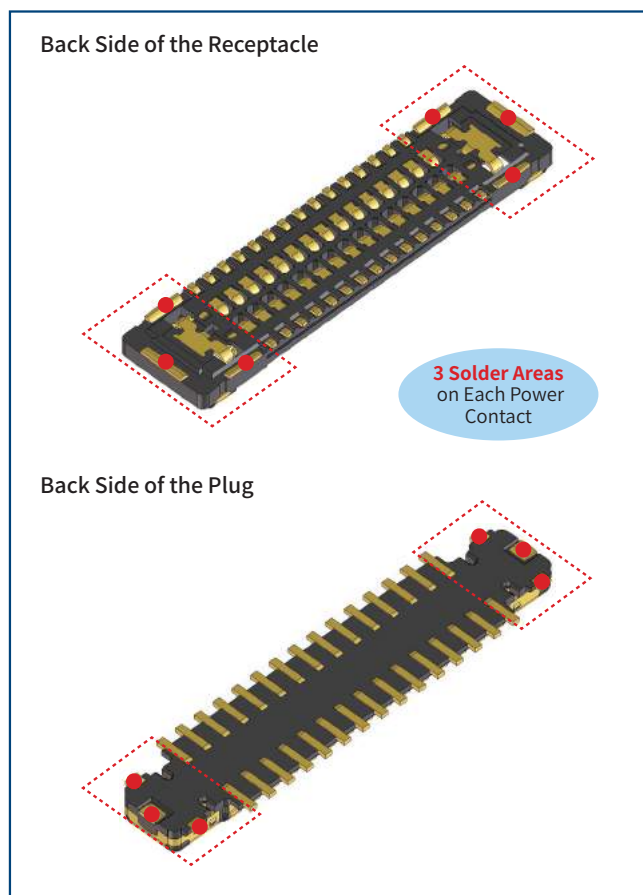

3 Solder Areas Enhance PCB Peeling Strength

## 5. High Contact Reliability

Both the power and signal contacts have a two-point contact design, ensuring high contact reliability.

## 6. Superior Mating Operability

Wide self-alignment range with metal guides offers a smooth mating operation.

( $\pm 0.29$ mm in pitch direction,  $\pm 0.24$ mm in width direction)

Additionally, the clear tactile click generated by the unique locking contact design ensures complete mating.

## 7. Halogen-Free

All materials and substances used to produce this product comply with Halogen-free standards.

\*As defined by IEC 61249-2-21

Br : 900ppm max., Cl : 900ppm max.,

Br+Cl : 1,500ppm max.

## Product Specifications

Rated Current	Signal Contact : 0.3A (Note 1) Power Contact : 5A	Operating Temperature (Note 2)	-55 to +85°C
		Storage Temperature Range (Note 3)	-10 to +60°C
Rated Voltage	30V AC/DC		

Items	Specifications	Conditions
Contact Resistance	Signal Contact : 50mΩ Max. Power Contact : 30mΩ Max.	Measured at 20mV AC, 1kHz, 1mA
Insulation Resistance	50MΩ Min.	Measured at 100V DC
Withstanding Voltage	No flashover or insulation breakdown	100V AC for 1 min.
Mating Durability	Contact Resistance : Signal Contact : 50mΩ Max. Power Contact : 50mΩ Max. No damage, crack or looseness of parts	10 mating cycles
Vibration Resistance	No electrical discontinuity of 1μs or more No damage, crack or looseness of parts	Frequency : 10 to 55Hz, single amplitude 0.75mm, 10 cycles in each of 3 axis directions for 5 minutes/cycle
Shock Resistance	No electrical discontinuity of 1μs or more No damage, crack or looseness of parts	Acceleration : 490m/s <sup>2</sup> , duration of pulse : 11ms at 3 times for 3 directions.
Humidity Resistance	Contact Resistance : Signal Contact : 50mΩ Max. Power Contact : 50mΩ Max. Insulation Resistance : 25MΩ Min. No damage, crack or looseness of parts	96 hours at temperature of 40±2°C and humidity range from 90 to 95%
Temperature Cycle	Contact Resistance : Signal Contact : 50mΩ Max. Power Contact : 50mΩ Max. Insulation Resistance : 50MΩ Min. No damage, crack or looseness of parts	-55°C for 30min. → +85°C for 30 min. for 5 Cycles (Stabilizing Time In Chamber : Within 2 to 3 min.)
Sulphur Dioxide	Contact Resistance : Signal Contact : 50mΩ Max. Power Contact : 50mΩ Max. No damage, crack or looseness of parts	Exposed in 25 PPM for 96h at 25°C, 75±5%RH. (Test standard : JIS C 60068)

Note 1 : The total current capacity is 12A Max. for signal contacts.

Note 2 : Includes temperature rise due to current flow.

Note 3 : The term "storage" refers to long-term-storage of unused items before they are mounted on the PCB.

Operating temperature range applies to the product in a temporary storage state such as non-powered after mounting on the PCB during transportation, etc.

## Materials / Finish

Part	Component	Material	Finish	Remarks
Plug Receptacle	Insulator	LCP	Black	UL94V-0
	Signal Contact	Copper Alloy	Gold Plated over Nickel Underplating	-
	Power Contact	Copper Alloy	Gold Plated over Nickel Underplating	-

## Product Number Structure

Refer to the chart below when determining the product specifications from the product number.  
Please select from the product numbers listed in this catalog when placing orders.

### Plug/Receptacle

**BK10C** **05** - **##** **DP** / **2** - **0.3** **V** **(8##)**

①      ②      ③      ④      ⑤      ⑥      ⑦      ⑧

① Series Name	BK10	⑤ Number of Power Contacts	2pos.
② Stacking Height	0.5mm	⑥ Contact Pitch	0.3mm
③ Number of Signal Contacts	30, 50pos.	⑦ Terminal Type	V : Straight SMT
④ Connector Type	DP : Double-row Plug DS : Double-row Receptacle	⑧ Packaging	(800) : Standard, Embossed Tape Packaging (20,000pcs per reel) (895) : Embossed tape packaging (1,000pcs per reel)

## Plug

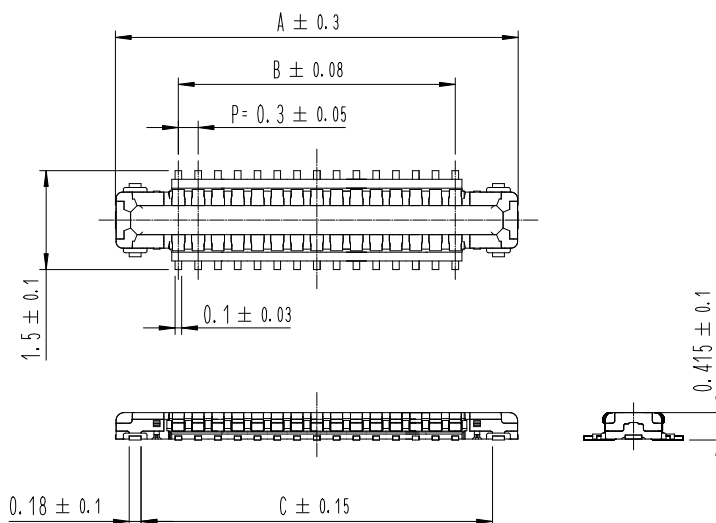

### Recommended PCB Layout

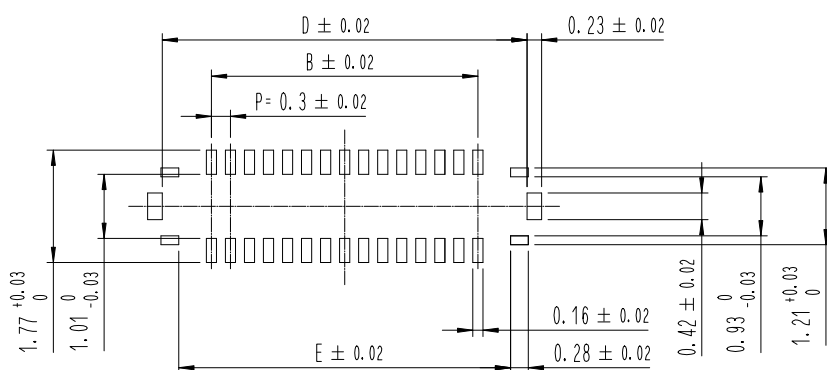

### Recommended Metal Mask Dimensions (Mask Thickness : 0.08mm)

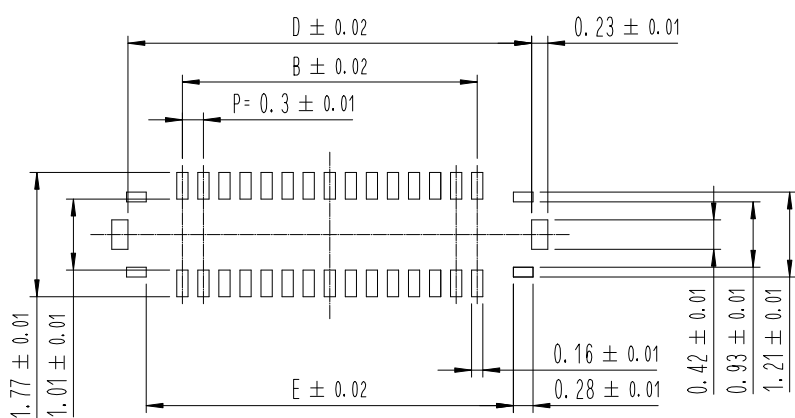

Unit : mm

Part No.	HRS No.	No. of Pos.		A	B	C	D	E	Purchase Unit	
		Signal Contact	Power Contact						## : 00	## : 95
		BK10C05-30DP/2-0.3V(8##)	CL0480-0878-0-##						30	2
BK10C05-50DP/2-0.3V(8##)	CL0480-0932-0-##	50	2	9.11	7.2	8.33	8.75	8.23	20,000pcs per reel	1,000pcs per reel

Note : This connector has no polarity.

## Receptacle

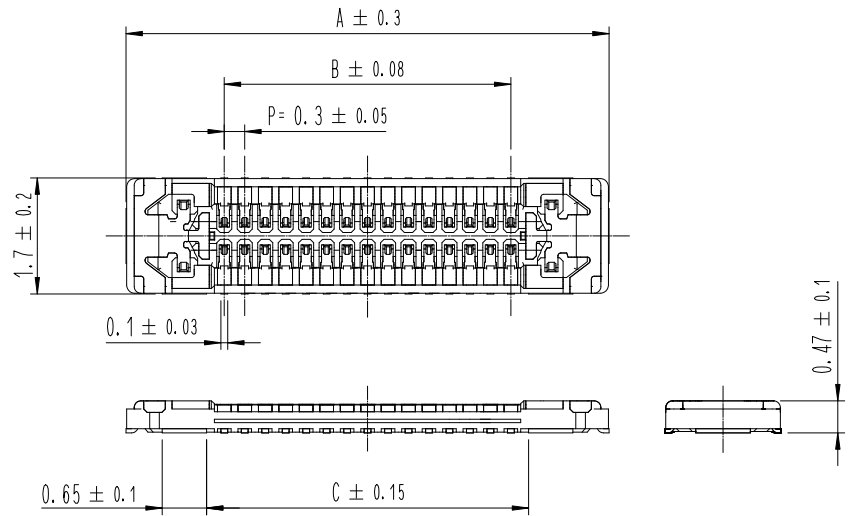

### Recommended PCB Layout

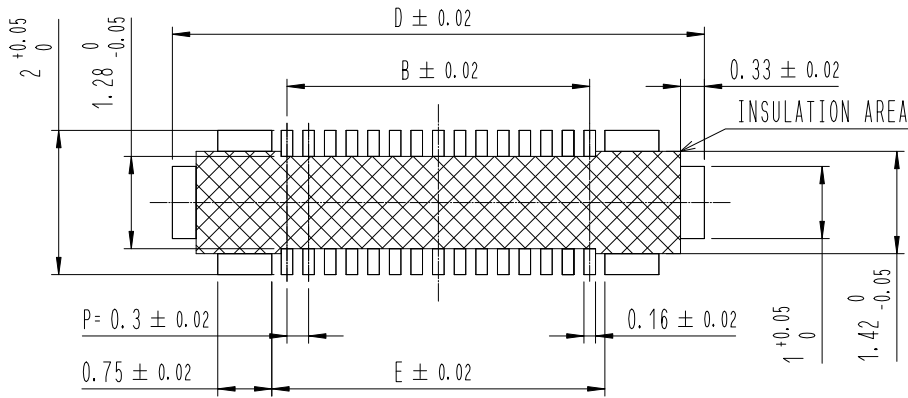

### Recommended Metal Mask Dimensions (Mask Thickness : 0.08mm)

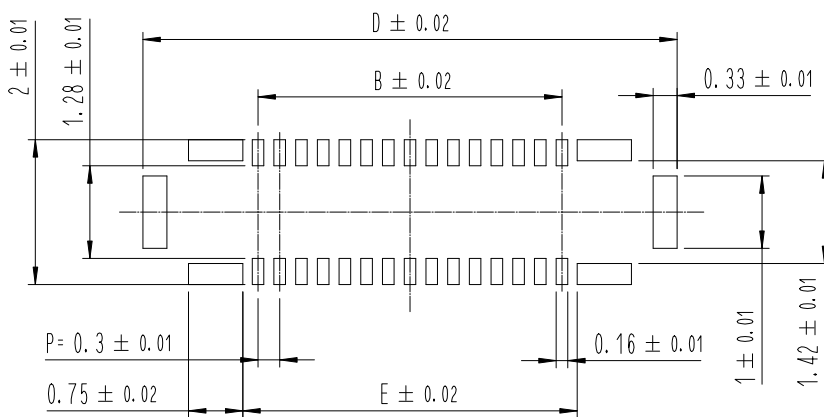

Unit : mm

Part No.	HRS No.	No. of Pos.		A	B	C	D	E	Purchase Unit	
		Signal Contact	Power Contact						## : 00	## : 95
BK10C05-30DS/2-0.3V(8##)	CL0480-0879-0-##	30	2	7.08	4.20	4.72	7.38	4.62	20,000pcs per reel	1,000pcs per reel
BK10C05-50DS/2-0.3V(8##)	CL0480-0933-0-##	50	2	10.08	7.20	7.72	10.38	7.62	20,000pcs per reel	1,000pcs per reel

Note : This connector has no polarity.

## Packaging Specifications Diagram

### Plug

#### Embossed Tape Dimensions

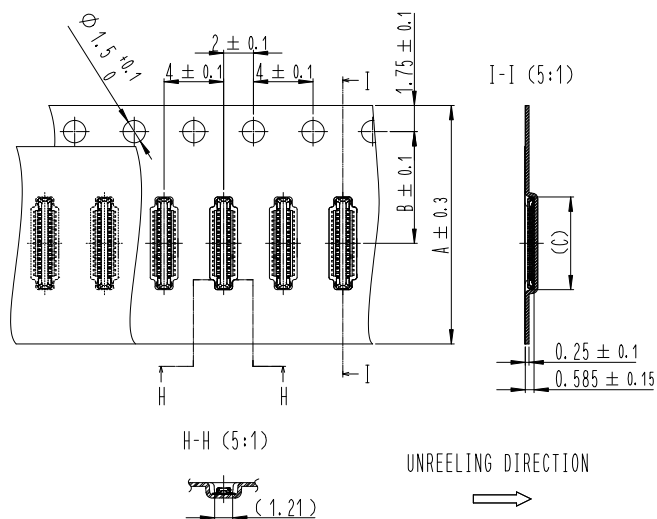

#### Reel Dimensions

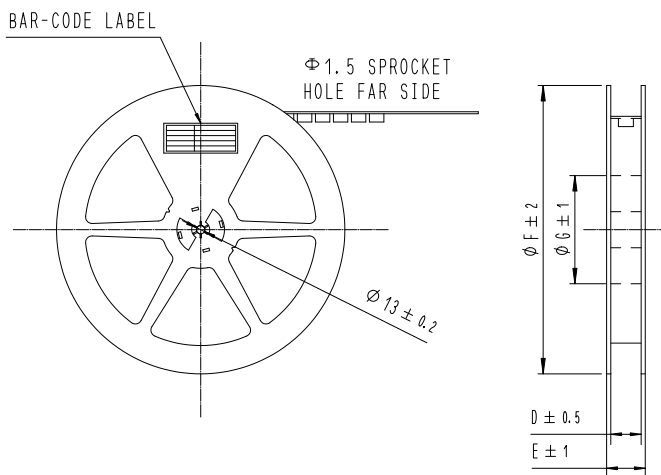

Unit : mm

Part No.	HRS No.	No. of Pos.		A	B	C	D	E	F	G
		Signal Contact	Power Contact							
BK10C05-30DP/2-0.3V(800)	CL0480-0878-0-00	30	2	16.0	7.5	6.22	17.5	21.5	380	80
BK10C05-30DP/2-0.3V(895)	CL0480-0878-0-95	30	2	16.0	7.5	6.22	17.5	21.5	180	60
BK10C05-50DP/2-0.3V(800)	CL0480-0932-0-00	50	2	24.0	11.5	9.22	25.5	29.5	380	80
BK10C05-50DP/2-0.3V(895)	CL0480-0932-0-95	50	2	24.0	11.5	9.22	25.5	29.5	180	60

### Receptacle

#### Embossed Tape Dimensions

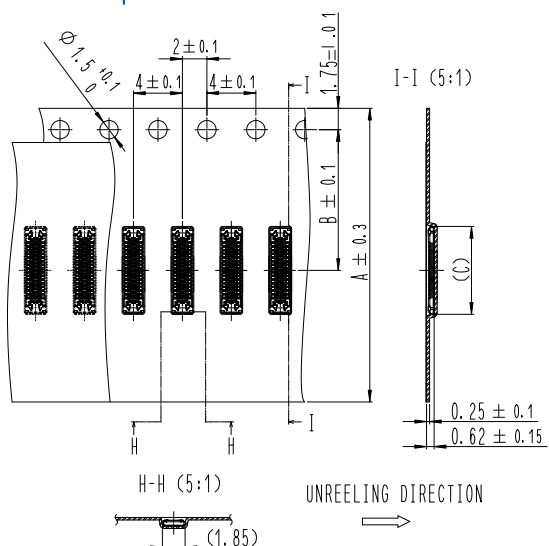

#### Reel Dimensions

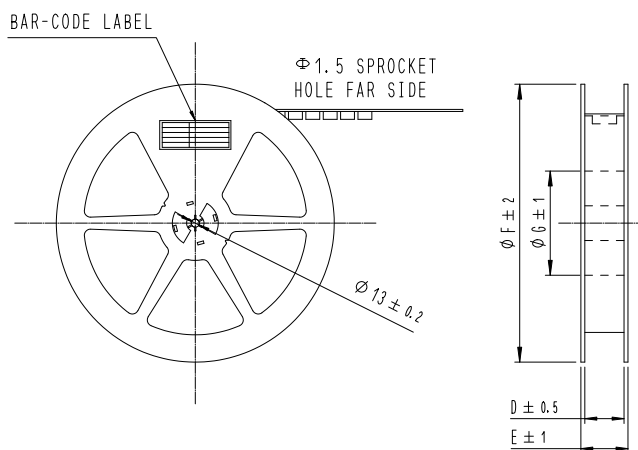

Unit : mm

Part No.	HRS No.	No. of Pos.		A	B	C	D	E	F	G
		Signal Contact	Power Contact							
BK10C05-30DS/2-0.3V(800)	CL0480-0879-0 00	30	2	24.0	11.5	7.18	25.5	29.5	380	80
BK10C05-30DS/2-0.3V(895)	CL0480-0879-0 95	30	2	24.0	11.5	7.18	25.5	29.5	180	60
BK10C05-50DS/2-0.3V(800)	CL0480-0933-0-00	50	2	24.0	11.5	10.18	25.5	29.5	380	80
BK10C05-50DS/2-0.3V(895)	CL0480-0933-0-95	50	2	24.0	11.5	10.18	25.5	29.5	180	60

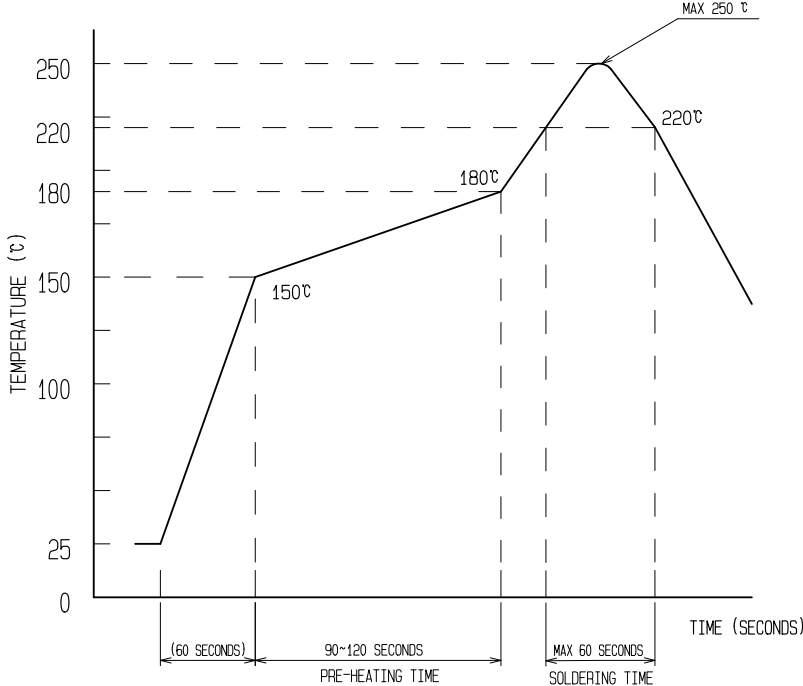

## Usage Precautions

<p>Recommended Solder Temperature Profile</p>	 <p>[Conditions]</p> <ol style="list-style-type: none"> <li>1. Peak Temperature : Maximum of 250°C</li> <li>2. Heated Section : 220°C Min., within 60 seconds</li> <li>3. Preheated Section : 150 to 180°C, 90 to 120 seconds</li> <li>4. Number of Reflow Cycles : Maximum of 2 cycles</li> </ol> <p>Note 1 : The temperature is the surface temperature of the PCB in the vicinity of the connector lead part.                  Note 2 : When using nitrogen reflow process, please mount the product with an oxygen concentration of 1000ppm or more. Please contact a Hirose representative if the concentration is below 1000ppm.</p>
<p>Recommended Manual Soldering Conditions</p>	<p>Soldering iron temperature : 340±10°C                  Soldering time : within 3 seconds</p>
<p>Recommended Metal Mask Thickness and Open Area to PCB Pattern Area Ratio</p>	<p>Thickness : 0.08mm                  Aperture ratio : 100% on the plug side, 100% on the Receptacle side</p>
<p>PCB Warpage</p>	<p>A maximum of 0.02mm at the center of the connector with reference to both ends of the connector.</p>
<p>Cleaning</p>	<p>Not recommended. If this product is cleaned, please evaluate the performance before using it. Cleaning may cause a change in the mating/unmating properties as well as environmental resistance.</p>
<p>Notes</p>	<ul style="list-style-type: none"> <li>• Insertion or removal prior to board mounting may result in contact deformation.</li> <li>• Avoid supporting the PCB only with the connectors. Support it by other means such as bolts, screws, posts, etc.</li> <li>• Avoid excessive prying during mating/unmating as it may result in damage.</li> <li>• Do not apply flux which will cause solder wicking during manual soldering.</li> <li>• This product may have slight color differences due to production lot variability, but this does not have any effect on the performance.</li> <li>• Please refer to the next page for mating/unmating precautions.</li> <li>• It is advised to secure the mated connectors to the board with housings and cushioning materials because the product can disengage from FPC routing, dropping or other impact.</li> <li>• Do not use the connector outside of the specifications (i.e., rated current, rated voltage, PCB design and operating environment, etc.). Such usage could lead to material outgassing, ignition, or short-circuit, etc.</li> <li>• Please use a proper stiffener on the back of the FPC. We recommend using a glass epoxy material with a minimum thickness of 0.3mm or a stainless steel material with a minimum of thickness of 0.2mm.</li> </ul>

Mar.1.2025 Copyright 2025 HIROSE ELECTRIC CO., LTD. All Rights Reserved.



## Connector Handling Precautions

### 【Connector Mating Method】

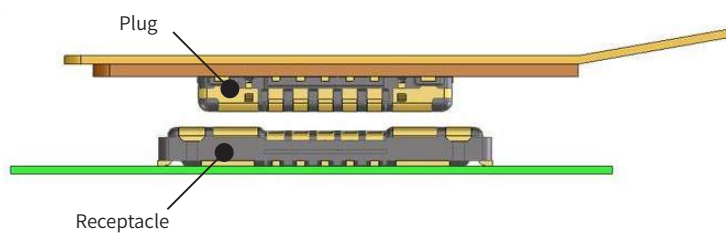

1. Locate the guides and align the connectors to the appropriate mating position.  
The connector has guide ribs on the receptacle for proper mating alignment.  
Align the connectors with the guide ribs.

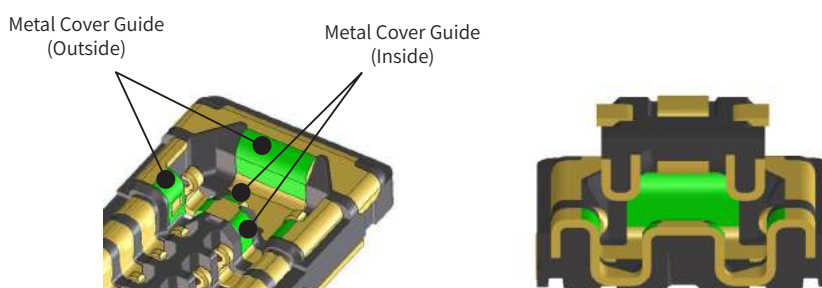

2. When the connector comes to the appropriate position, the connector will lower into place as indicated by the change in mated height.
3. When the connectors has lowered into place, the connector pair will be parallel to each other and cannot be moved back and forth or left and right.  
Please complete mating from this state by applying force.

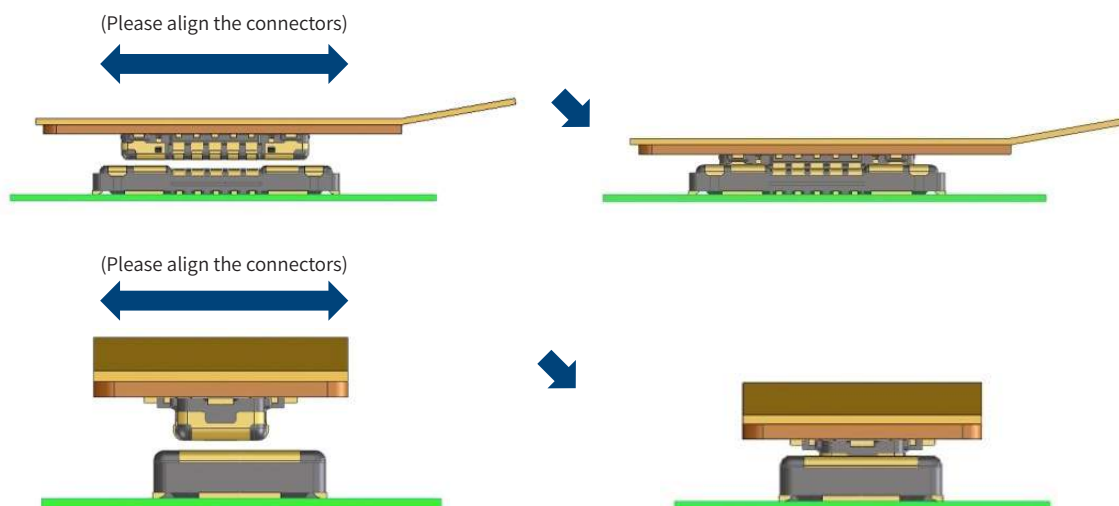

4. Please make sure connectors are mated completely. If one side is floating or the connectors are mated at an angle, please unmate and then redo the mating procedure following the steps described.



**【Connector Un-Mating Precautions】**

1. It is recommended to remove the connector by pulling perpendicular to the connector mounted surface.  
However, unmating FPC-to-board connectors can become more difficult with higher pin count connectors and thinner FPCs.

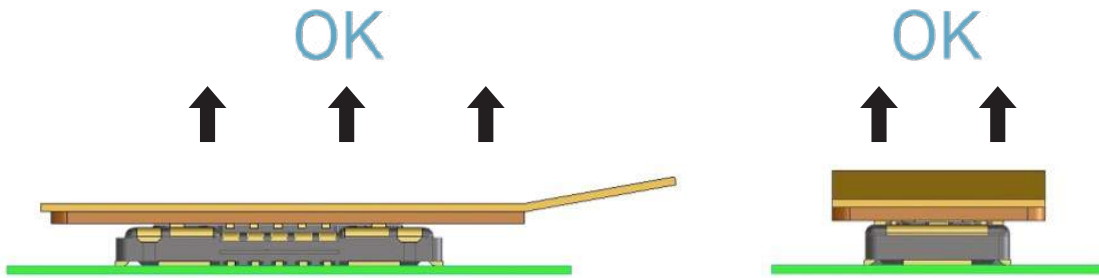

2. If it is difficult to remove the connector parallel to the mounting surface, remove it diagonally towards the pitch direction.  
Do not remove the connector towards the width direction as it may put a large amount of stress on the contacts.



3. If the FPC is not rigid enough, there is a possibility of solder peeling or connector damage.  
Please check the repetitive operation of the FPC planned to be used in advance, such as during the early stage build.  
Please do not remove the FPC by holding one corner and pulling at a diagonal as this will put a great amount of stress on the contacts.

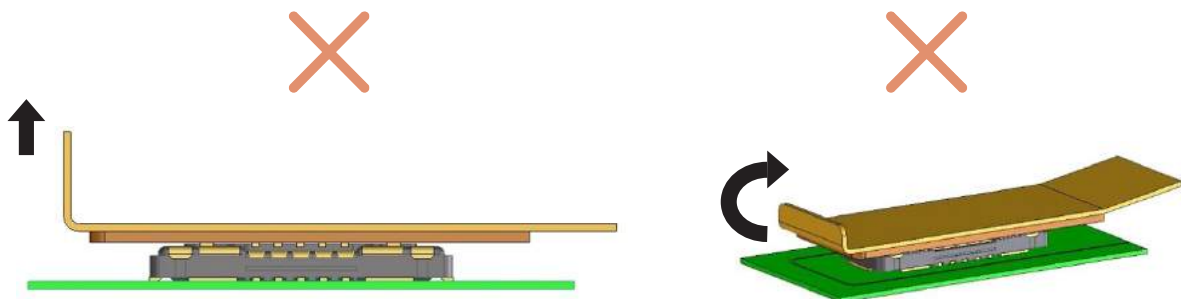

## While Taking into Consideration

Specifications mentioned in this catalog are reference values.

When considering to order or use this product, please confirm the Drawing and Product Specifications sheets.

Use an appropriate cable when using the connector in combination with cables.

If considering usage of a non-specified cable, please contact your sales representative.

If assembly process is done by jigs & tools which are not identified by Hirose, assurance will not be given.

If considering usage for below mentioned applications, please contact your sales representative.

In cases where the application will demand a high level of reliability, such as automotive, medical instruments, public infrastructure, aerospace/ defense etc. Hirose must review before assurance of reliability can be given.