

Apr.1.2024 Copyright 2024 HIROSE ELECTRIC CO., LTD. All Rights Reserved.  
In case of consideration for using Automotive equipment / device which demand high reliability, kindly contact our sales window correspondents.

COUNT	DESCRIPTION OF REVISIONS	B	Y	CHKD	DATE	COUNT	DESCRIPTION OF REVISIONS	B	Y	CHKD	DATE
1	RE-6-2736	PSG	JHW		22.06.14						
9	RE-6-3103	JDW	JHW		23.08.30						

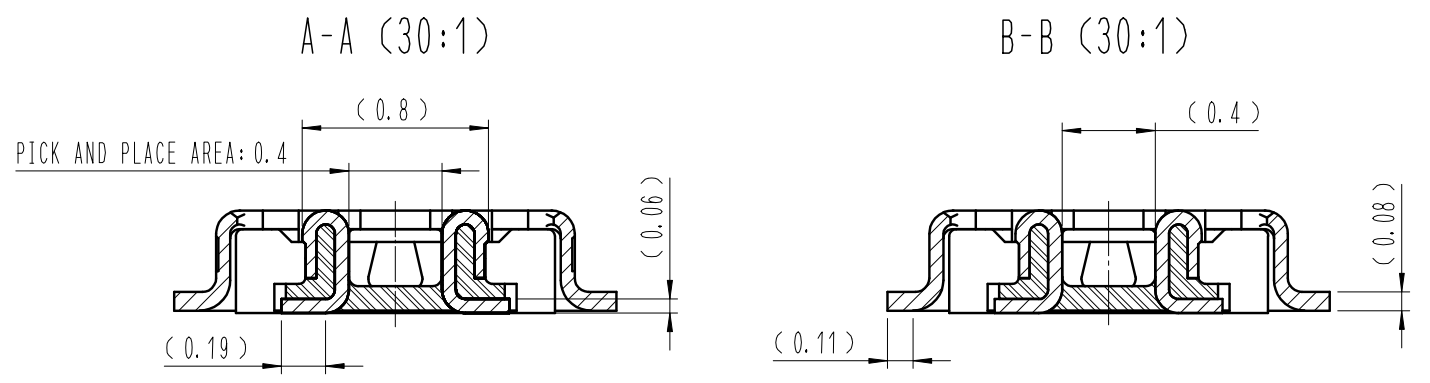

△ ENGAGEMENT FIGURE (30:1)

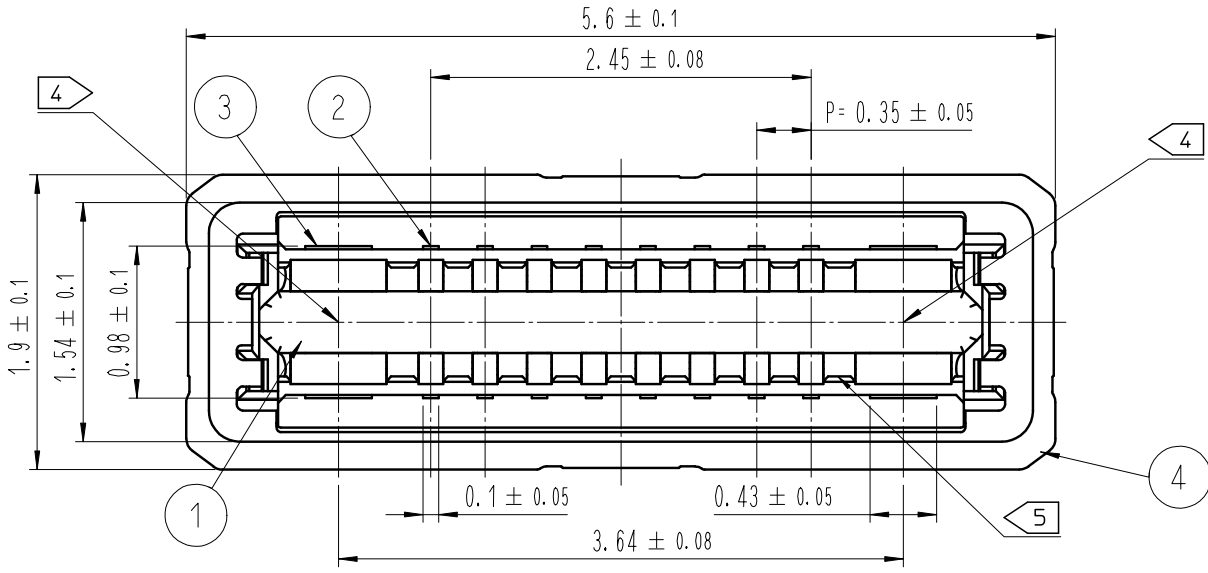
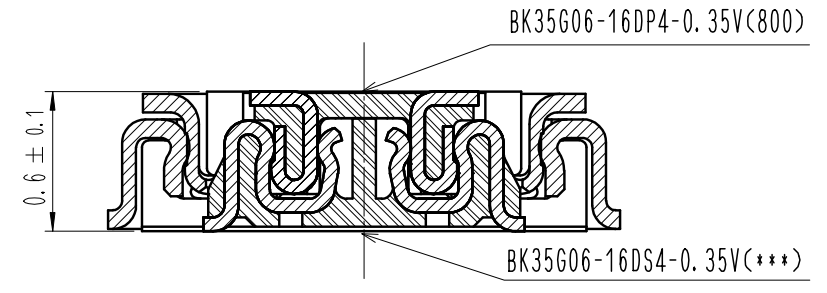

SIGNAL CONTACT

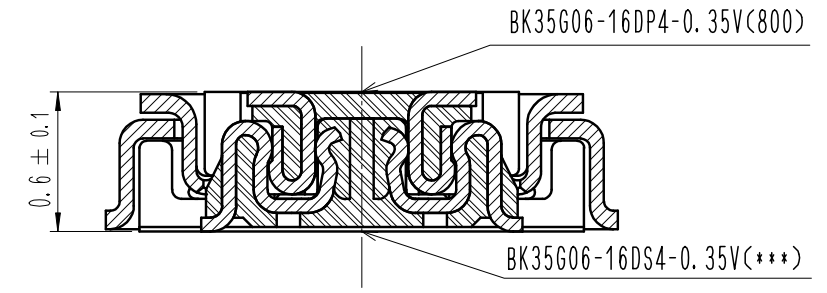

POWER CONTACT

HRS DRAWING FOR REFERENCE

- NOTE
- 1. ALL LEAD CO-PLANARITY SHALL BE 0.08mm MAX.
  - 2. CONTACT PLATING SPECIFICATIONS  
CONTACT AREA : GOLD 0.05 μm MIN  
SMT LEAD : GOLD 0.05 μm MIN  
(NO GOLD PLATING IS ACCEPTABLE EXCEPT CONTACT POINTS AND SMT LEADS)  
UNDERPLATING : NICKEL 1 μm MIN  
(SURFACE : SEALING)
  - 3. OUTER SHIELD PLATING SPECIFICATIONS  
SMT LEAD : GOLD 0.03 μm MIN  
UNDERPLATING : NICKEL 1 μm MIN  
(SURFACE : SEALING)
  - 4. HRS MARK AND CAV NO. ARE INDICATED IN APPROX POSITION SHOWN.
  - 5. A PART OF THE WALL COULD BE NOTCHED

DRAWING FOR REFERENCE  
This is subject to change without notice

4	COPPER ALLOY	3								
3	COPPER ALLOY	2			7	PS		BLACK (PLASTIC REEL)		
2	COPPER ALLOY	2			6	POLYESTER		CLEAR (COVER TAPE)		
1	LCP	UL94 V-0, BLACK			5	PS		(EMBOSSED CARRIER TAPE)		
NO.	MATERIAL	FINISH, REMARKS	NO.	MATERIAL	FINISH, REMARKS					
REMARKS						DRAWN	DESIGNED	CHECKED	APPROVED	RELEASED
						S. G. PARK	S. G. PARK	H. W. JO	H. W. JO	22.02.17
						22.02.17	22.02.17	22.02.17	22.02.17	
CODE NO. (OLD)	DRAWING NO. △EDC3-633831-80		PART NO. BK35G06-16DP4-0.35V(800)							
SCALE 20:1	UNITS mm		HRS HIROSE KOREA CO., LTD.			CODE NO. △CL 6695-0005-0-800	1/3			

Apr.1.2024 Copyright 2024 HIROSE ELECTRIC CO., LTD. All Rights Reserved.  
In case of consideration for using Automotive equipment / device which demand high reliability, kindly contact our sales window correspondents.

7 RECOMMENDED PCB LAYOUT

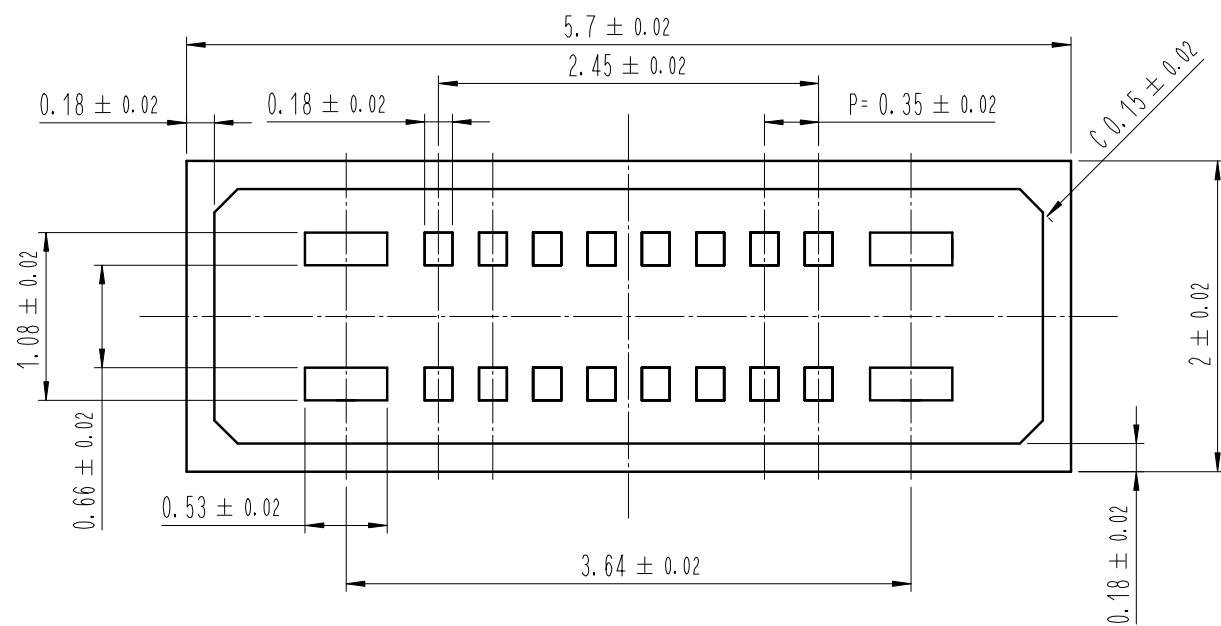

7 RECOMMENDED METAL MASK DIMENSIONS

METAL MASK THICKNESS : 80 μm

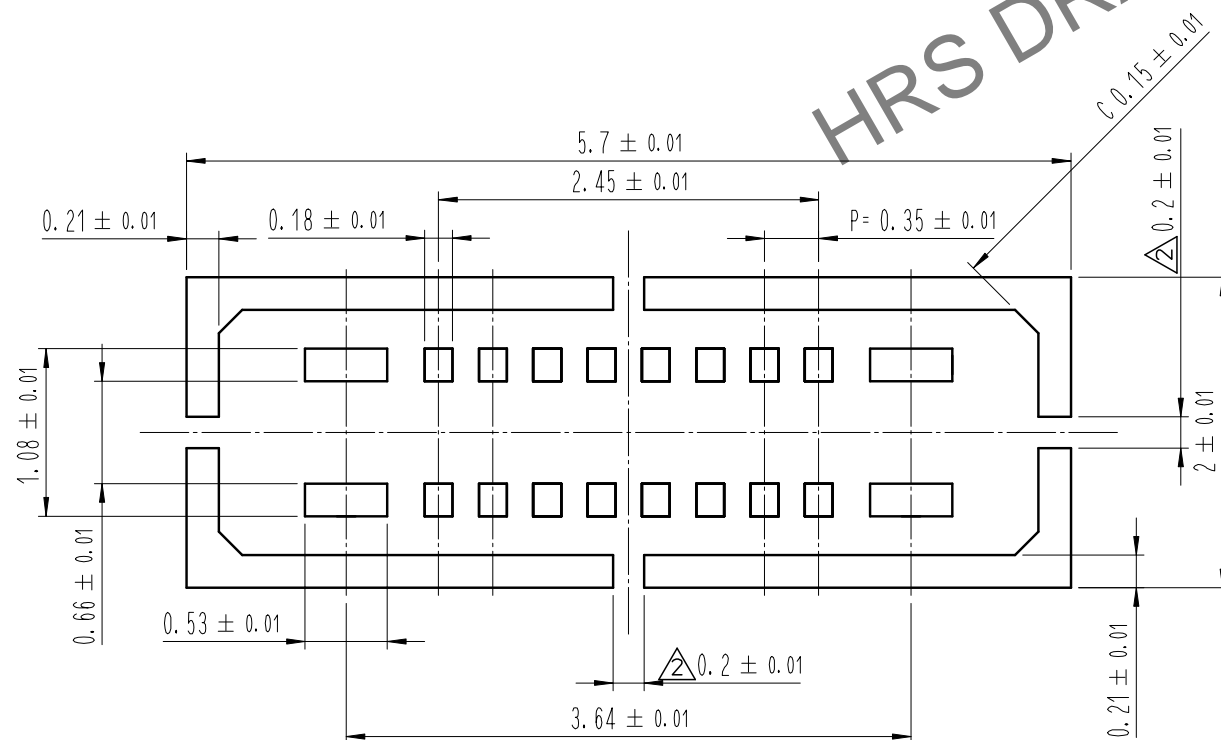

6 RECOMMENDED REFLOW TEMPERATURE PROFILE USING LEAD-FREE SOLDER PASTE.

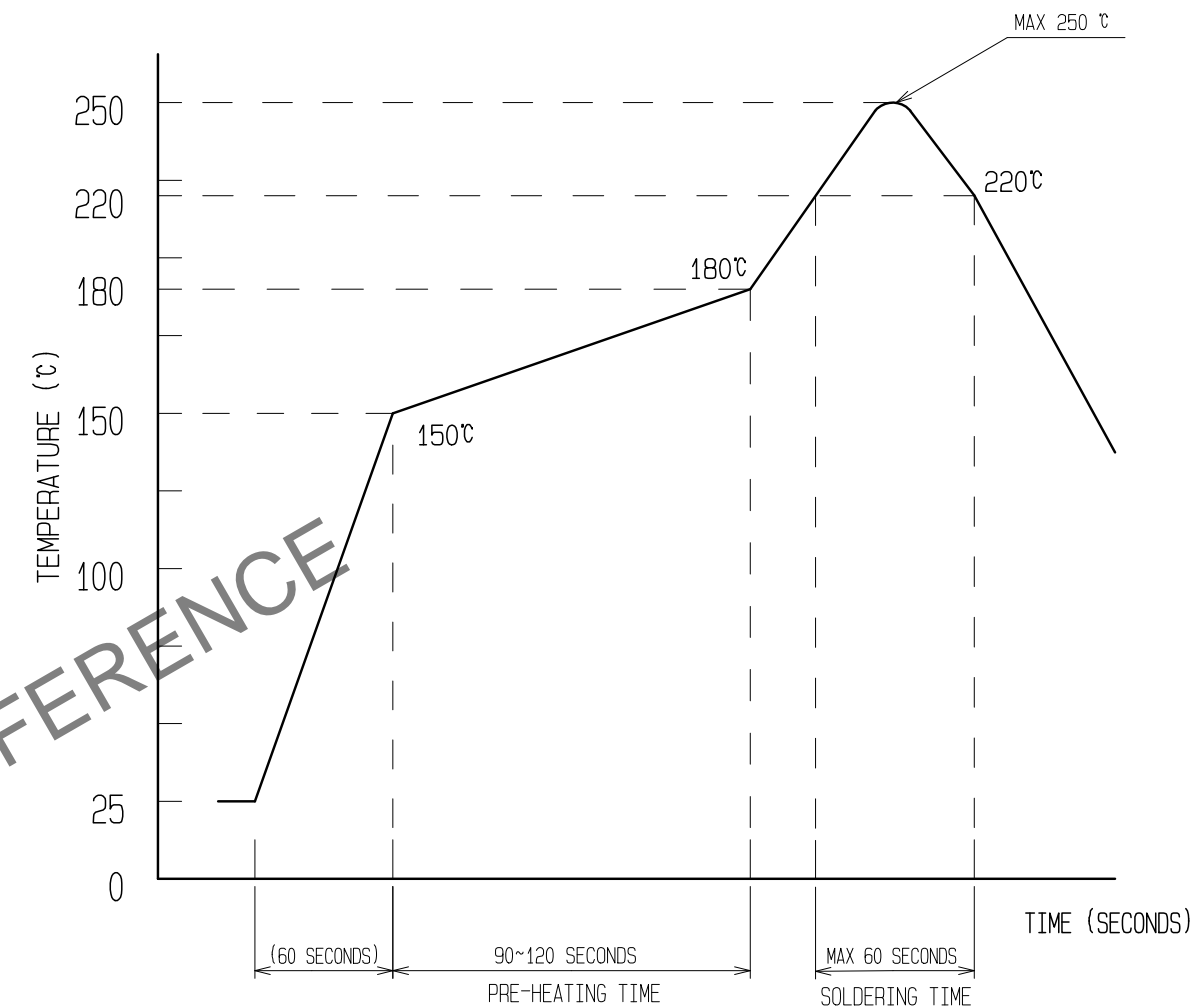

REFLOW METHOD : N<sub>2</sub> REFLOW  
 NUMBER OF REFLOW CYCLES : 2 CYCLES MAX.  
 1) REFLOW TIME  
 DURATION ABOVE 220°C, 60 SEC MAX.  
 (PEAK TEMPERATURE : 250°C MAX)  
 2) PRE-HEAT TIME  
 PRE-HEAT TEMPERATURE(MIN): 150°C  
 PRE-HEAT TEMPERATURE(MAX): 180°C  
 PRE-HEAT TIME: 90-120 SEC.

6 THIS TEMPERATURE PROFILE IS PER THE CONDITIONS SHOWN ABOVE. ADDITIONAL FACTORS SUCH AS SOLDER PASTE TYPE, PCB SIZE AND OTHER MOUNTED COMPONENTS COULD AFFECT THE PROFILE. THEREFORE, A THOROUGH EVALUATION OF MOUNTING CONDITION IS REQUIRED PRIOR TO PRODUCTION. TEMPERATURE IS MEASURED AT CONTACT LEAD.

7 PLEASE CONTACT US IN CASE YOU WILL MAKE DIFFERENT SETTINGS FROM OUR RECOMMENDATION.  
 8 . THIS PRODUCT SATISFIES HALOGEN FREE REQUIREMENTS DEFINED AS 900ppm MAXIMUM CHLORINE, 900ppm MAXIMUM BROMINE, AND 1500ppm MAXIMUM TOTAL OF CHLORINE AND BROMINE.  
 9 . THIS PRODUCT COMPLY WITH RoHS.

 SCALE 10:1 UNITS mm	DRAWING NO.  EDC3-633831-80	PART NO. BK35G06-16DP4-0.35V(800)
	HIROSE KOREA CO., LTD.	CODE NO  CL 6695-0005-0-800

Apr.1.2024 Copyright 2024 HIROSE ELECTRIC CO., LTD. All Rights Reserved.  
In case of consideration for using Automotive equipment / device which demand high reliability, kindly contact our sales window correspondents.

### EMBOSSED CARRIER TAPE PACKAGING (5:1)

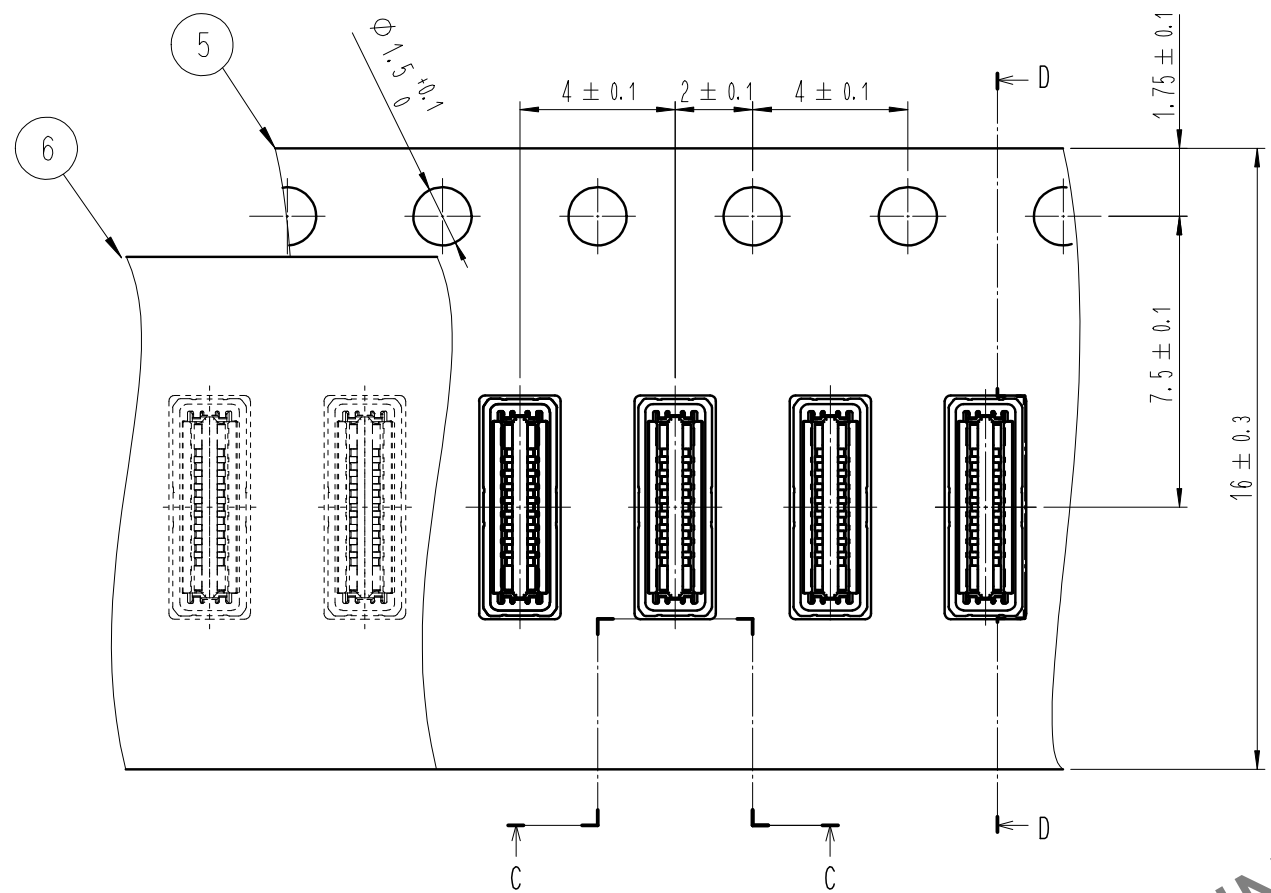

#### C-C (5:1)

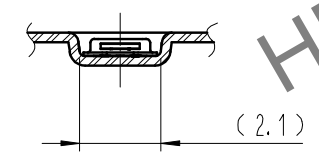

#### D-D (5:1)

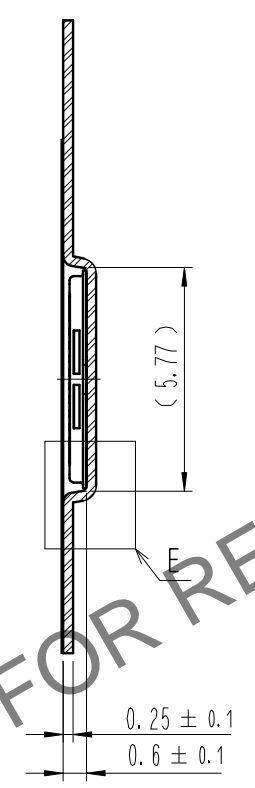

### STYLE AND DIMENSION OF REEL (FREE)

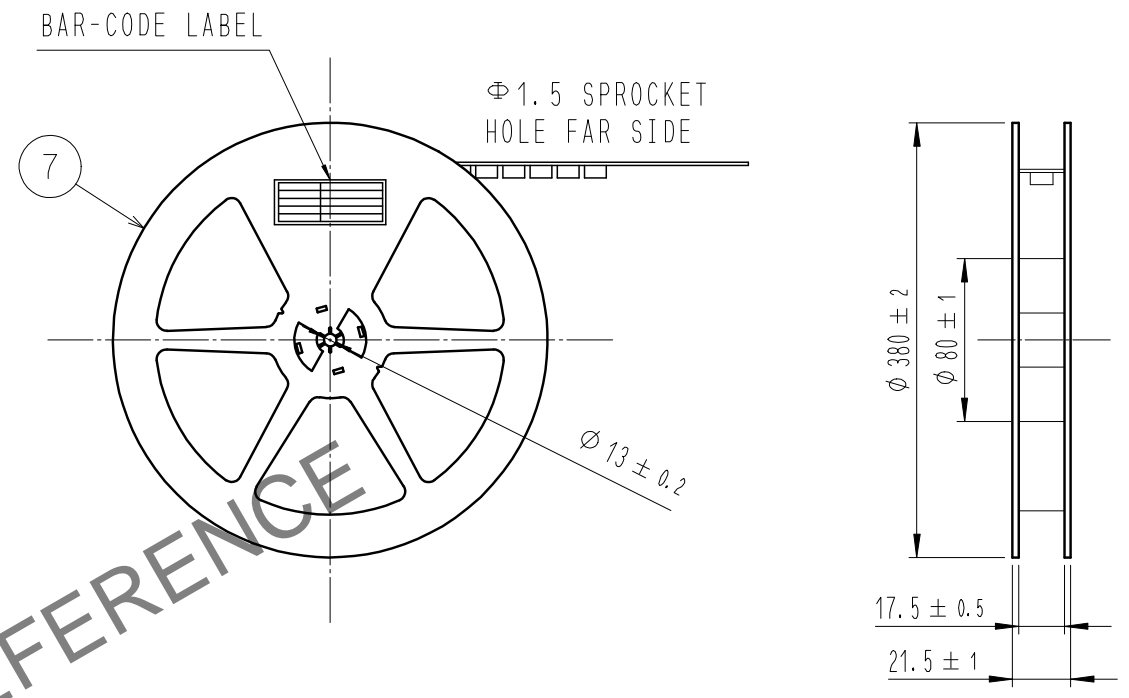

#### DETAIL OF PART No. LABEL

SUPPLIER	
QUANTITY	
PART NO.	
CODE NO.	
DATE OF MANUFACTURED	
生産月日	年 月 日
図番	** ** *
品名	BK35G06-16DP4-0.35V(800)
納入数量	20,000個
納入者	HIROSE KOREA

#### E (10:1)

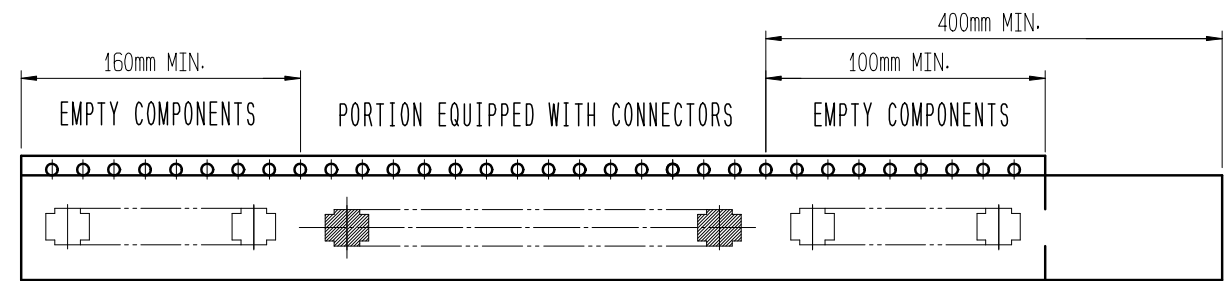
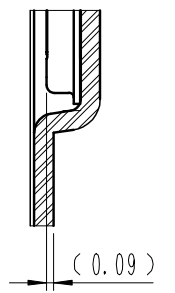

12 TAPING(FREE)

- 10 . PER REEL 20,000 CONNECTORS.
- 11 . THE DIMENSIONS IN PARENTHESES ARE FOR REFERENCE.
- 12 > REFER TO JIS C 0806, IEC-60286-3 (PACKAGING OF COMPONENTS FOR AUTOMATIC HANDLING)

	DRAWING NO.	△EDC3-633831-80	PART NO.	BK35G06-16DP4-0.35V(800)
	SCALE	10:1	CODE NO.	△CL 6695-0005-0-800
	UNITS	mm		

3/3