

Apr.1.2024 Copyright 2024 HIROSE ELECTRIC CO., LTD. All Rights Reserved.  
In case of consideration for using Automotive equipment / device which demand high reliability, kindly contact our sales window

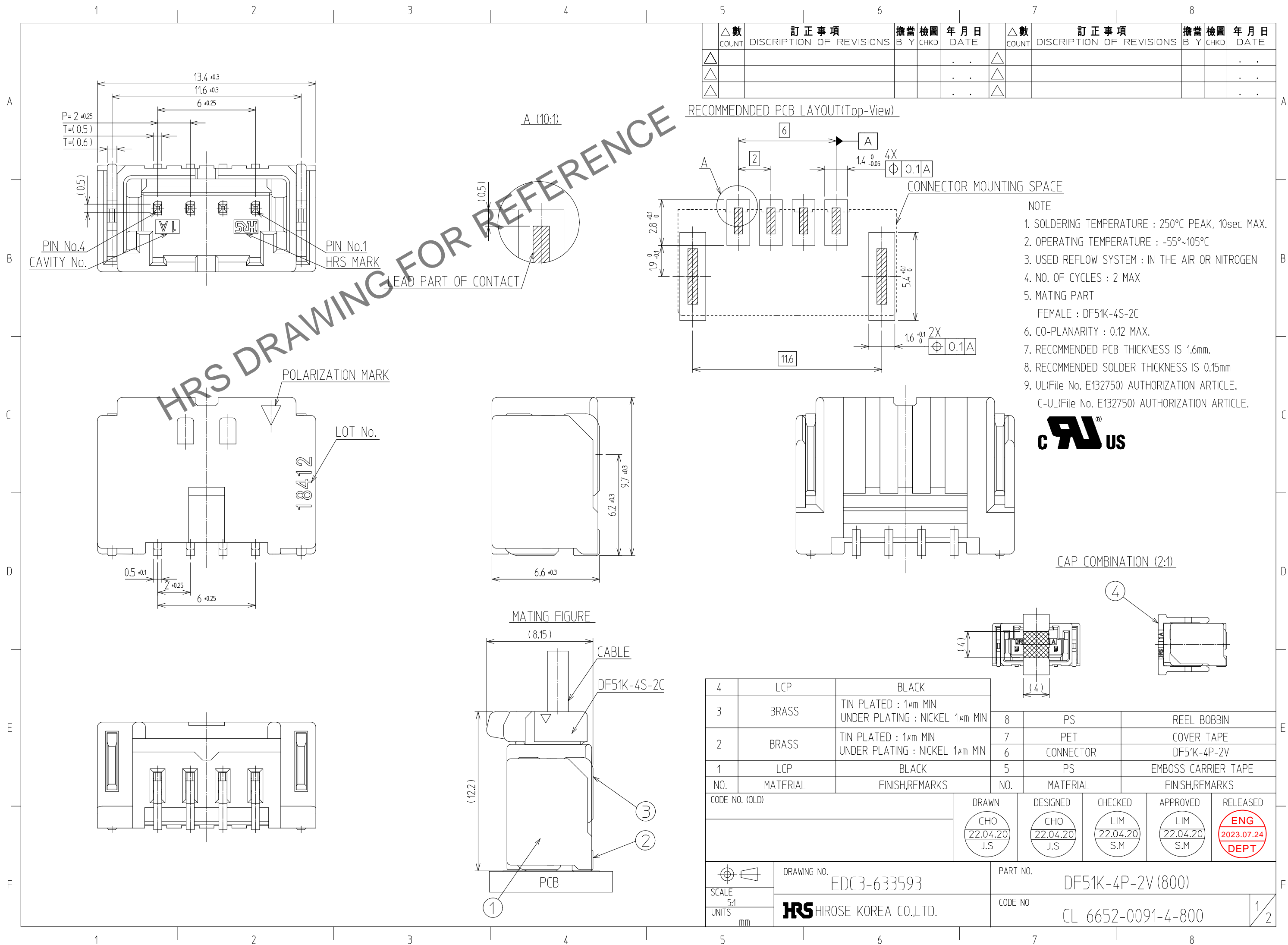

△數 COUNT	訂正事項 DISCRIPTION OF REVISIONS	擔當 B	檢圖 CHKD	年月日 DATE	△數 COUNT	訂正事項 DISCRIPTION OF REVISIONS	擔當 B	檢圖 CHKD	年月日 DATE
△					△				
△					△				
△					△				

4	LCP	BLACK	8	PS	REEL BOBBIN
3	BRASS	TIN PLATED : 1μm MIN UNDER PLATING : NICKEL 1μm MIN	7	PET	COVER TAPE
2	BRASS	TIN PLATED : 1μm MIN UNDER PLATING : NICKEL 1μm MIN	6	CONNECTOR	DF51K-4P-2V
1	LCP	BLACK	5	PS	EMBOSS CARRIER TAPE
NO.	MATERIAL	FINISH,REMARKS	NO.	MATERIAL	FINISH,REMARKS

CODE NO. (OLD)		DRAWN	DESIGNED	CHECKED	APPROVED	RELEASED
		CHO 22.04.20 J.S	CHO 22.04.20 J.S	LIM 22.04.20 S.M	LIM 22.04.20 S.M	ENG 2023.07.24 DEPT

SCALE 5:1 UNITS mm	DRAWING NO. EDC3-633593	PART NO. DF51K-4P-2V (800)
	HRS HIROSE KOREA CO.,LTD.	CODE NO CL 6652-0091-4-800

In case of consideration for using Automotive equipment / device which demand high reliability, kindly contact our sales window.

△數 COUNT	訂正事項 DISCRIPTION OF REVISIONS	擔當 B	檢圖 CHKD	年月日 DATE	△數 COUNT	訂正事項 DISCRIPTION OF REVISIONS	擔當 B	檢圖 CHKD	年月日 DATE
△				..	△				..
△				..	△				..
△				..	△				..

PACKING STYLE

PACKING STYLE DRAWING

REEL DIMENTSION (FREE)

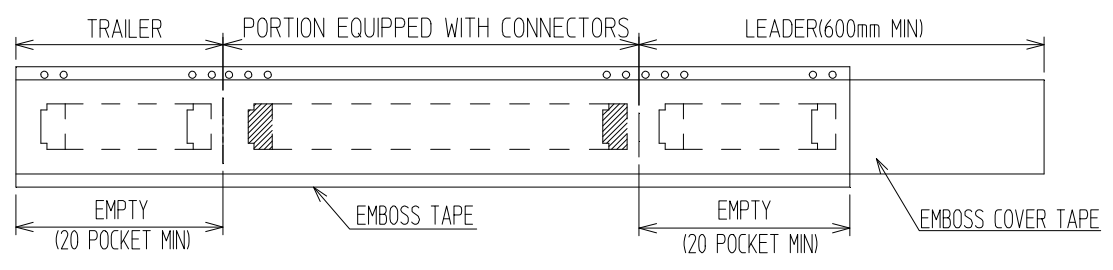
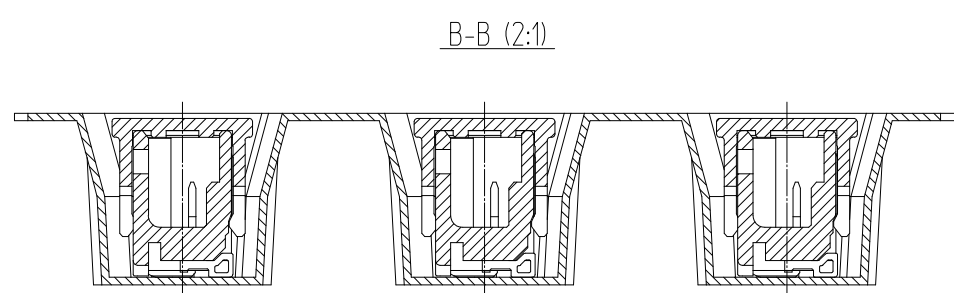
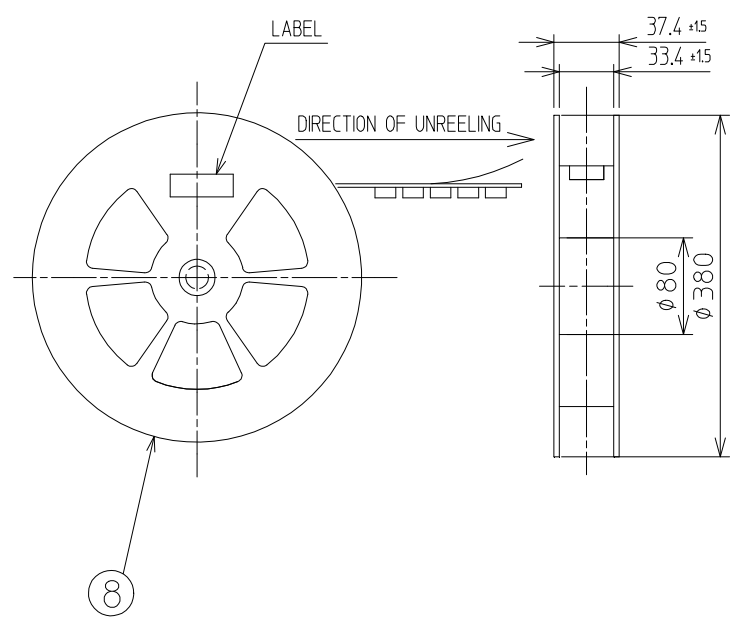
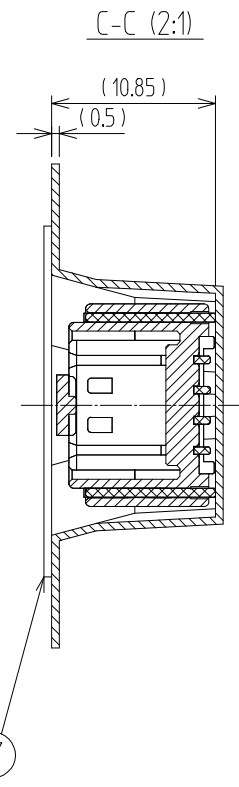
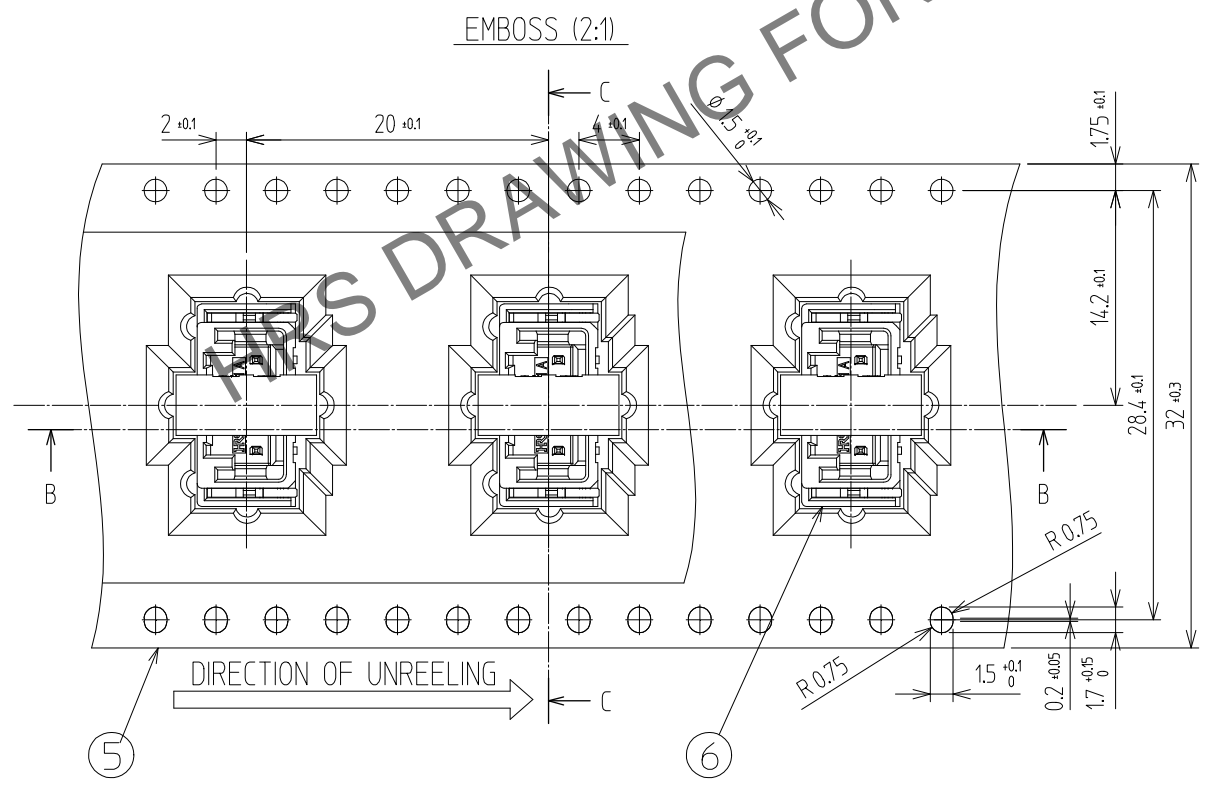

 SCALE 5:1 UNITS mm	DRAWING NO. EDC3-633593	PART NO. DF51K-4P-2V(800)	2/2
	 HIROSE KOREA CO.,LTD.	CODE NO CL 6652-0091-4-800	