

Jul.1.2024 Copyright 2024 HIROSE ELECTRIC CO., LTD. All Rights Reserved.  
In case of consideration for using Automotive equipment / device which demand high reliability, kindly contact our sales window correspondents.

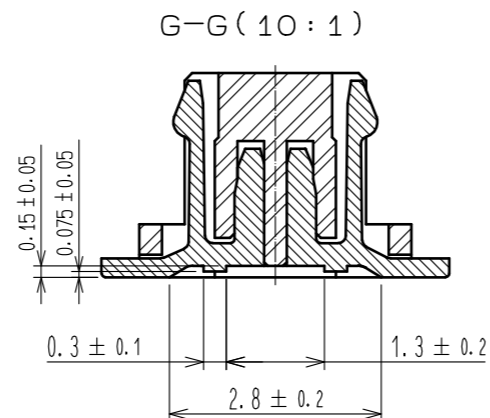

CODE No.	CONTACT	A	B	C	D	E	F
CL537-0303-0-86	20	7.1	4.5	5.2	5.6	5.3	8.1
CL537-0305-5-86	30	9.6	7.0	7.7	8.1	7.8	10.6
CL537-0312-0-86	32	10.1	7.5	8.2	8.6	8.3	11.1
CL537-0306-8-86	36	11.1	8.5	9.2	9.6	9.3	12.1
CL537-0307-0-86	40	12.1	9.5	10.2	10.6	10.3	13.1
CL537-0309-6-86	50	14.6	12.0	12.7	13.1	12.8	15.6
CL537-0311-8-86	60	17.1	14.5	15.2	15.6	15.3	18.1

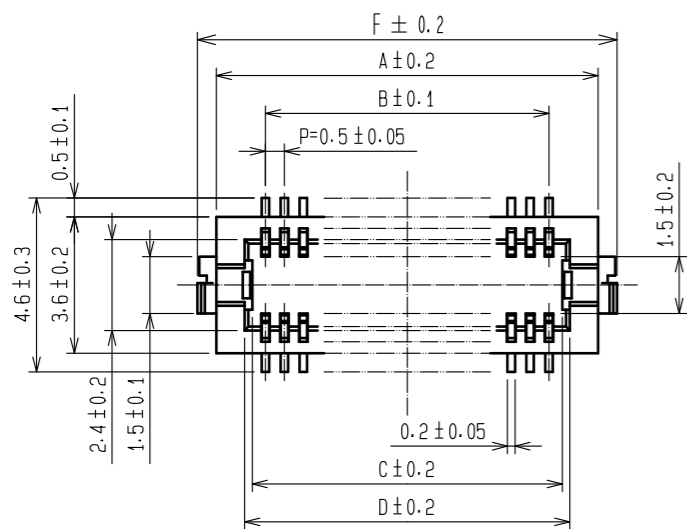
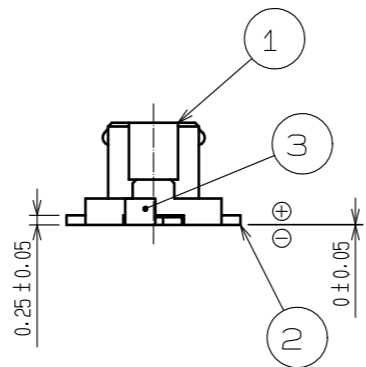
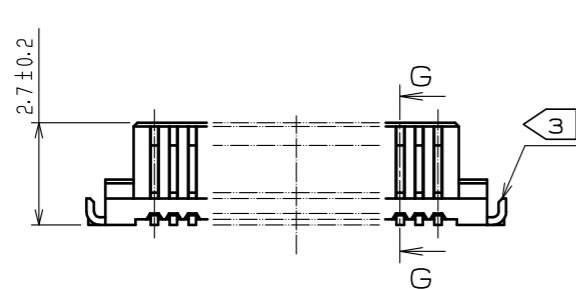

RECOMMEND METAL MASK PATTERN (10:1)

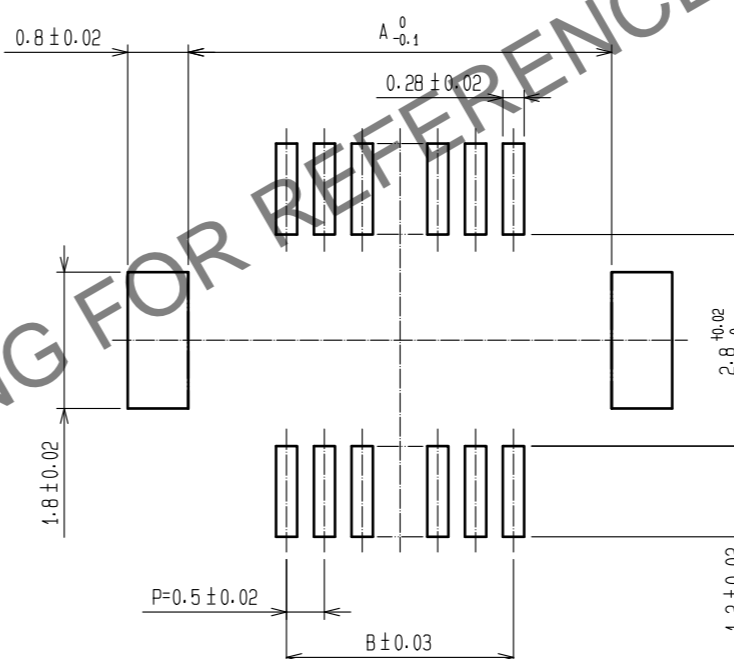

RECOMMENDED LAND PATTERN (10:1)

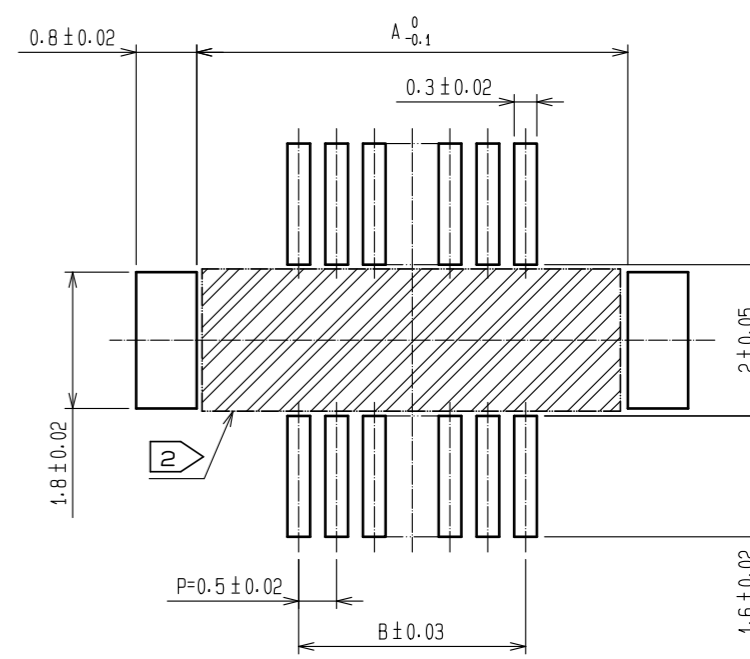

RECOMMENDED THICKNESS OF SOLDER PASTE : 120 μm

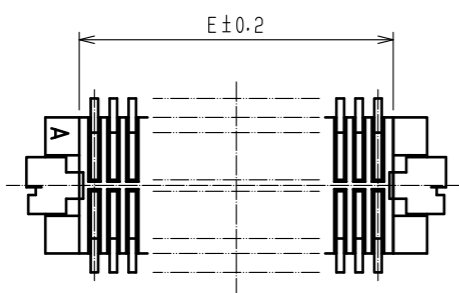

- NOTES 1 LEAD CO-PLANARITY SHALL BE 0.08 mm MAX.  
 2 IF THERE IS PATTERN ON PART, THERE IS A POSSIBILITY THAT IT WILL MAKE CONTACT WITH THE LEADS.  
 3 REINFORCED METAL FITTINGS AS FOLLOWS.

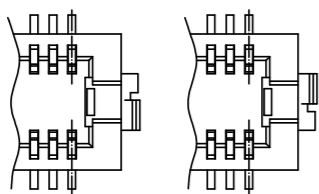

NO.	MATERIAL	FINISH . REMARKS	NO.	MATERIAL	FINISH . REMARKS
2	PHOSPHOR BRONZE	CONTACT AREA:GOLD PLATED 0.2μm min LEAD AREA:GOLD PLATED 0.015μm min OTHERS(UNDER PLATING):NICKEL PLATED 2μm min	7	PS	CLEAR (REINFORCEMENT COLLAR)
1	POLYAMIDE	UL94V-0, NATURAL (BEIGE)	6	PS	BLACK (PLASTIC REEL)
			5	POLYESTER	CLEAR (COVER TAPE)
			4	PS	CLEAR (EMBOSSED CARRIER TAPE)
			3	BRASS	TIN PLATED 2μm min (UNDER PLATING):NICKEL 1μm min

  

UNITS	SCALE	COUNT	DESCRIPTION OF REVISIONS	DESIGNED	CHECKED	DATE
mm	5 : 1	△				

APPROVED	: WR. FUKUCHI	20190409	DRAWING NO.	EDC-160937-86-78
CHECKED	: WR. FUKUCHI	20190409	PART NO.	DF12B-*DS-0.5V(86)
DESIGNED	: KT. KUSAKA	20190409	CODE NO.	CL537
DRAWN	: RN. IIDA	20190409		

Jul.1.2024 Copyright 2024 HIROSE ELECTRIC CO., LTD. All Rights Reserved.  
 In case of consideration for using Automotive equipment / device which demand high reliability, kindly contact our sales window correspondents.

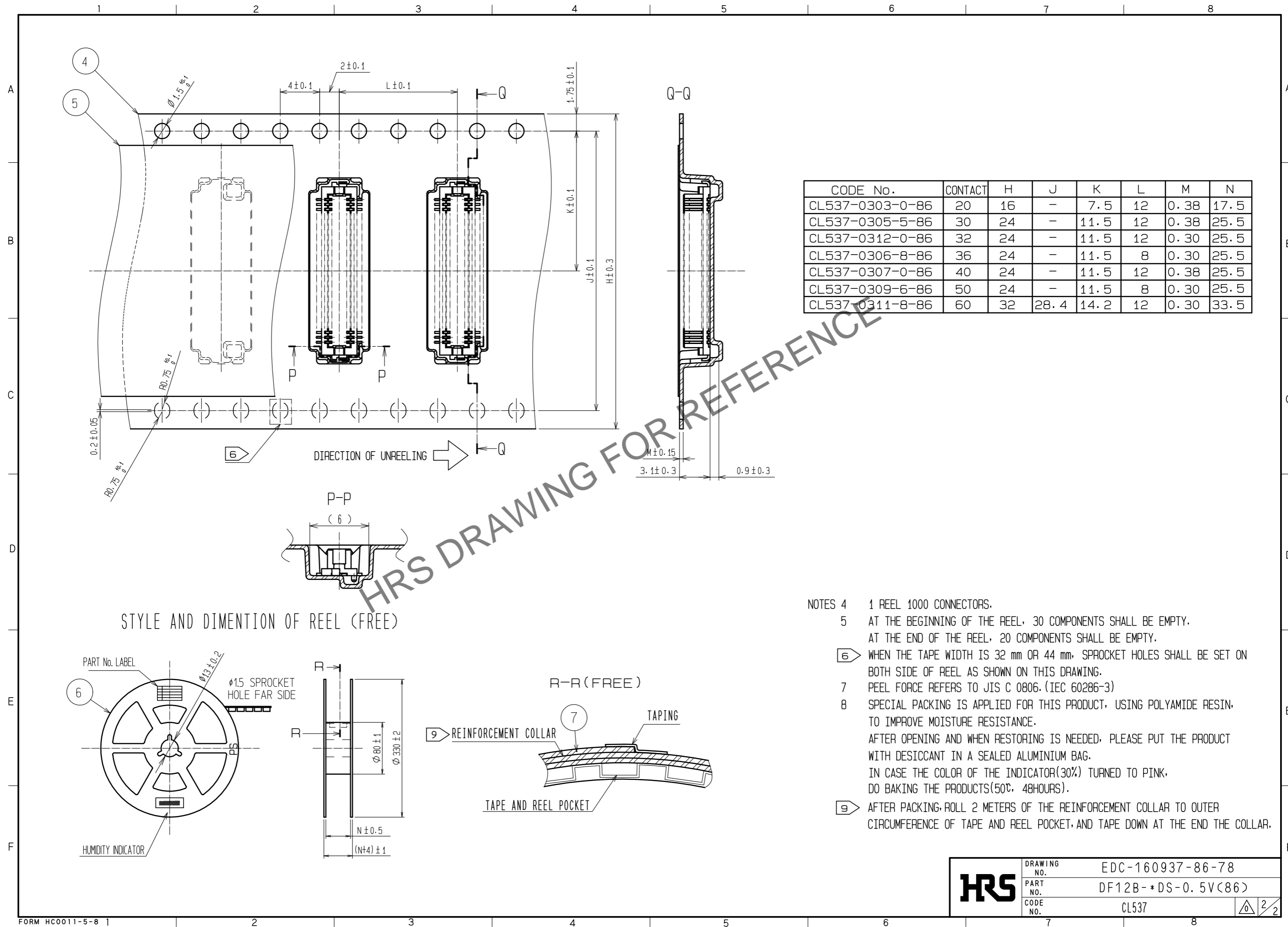

<b>HRS</b>	DRAWING NO.	EDC-160937-86-78
	PART NO.	DF12B-*DS-0.5V(86)
	CODE NO.	CL537