

CRIMP CONTACT : CRIMP QUALITY STANDARD

PART NO.

DF11#-\*\*\*\*SC\*\*(%)

CODE NO.

CL543-\*\*\*\*-\*\*\*

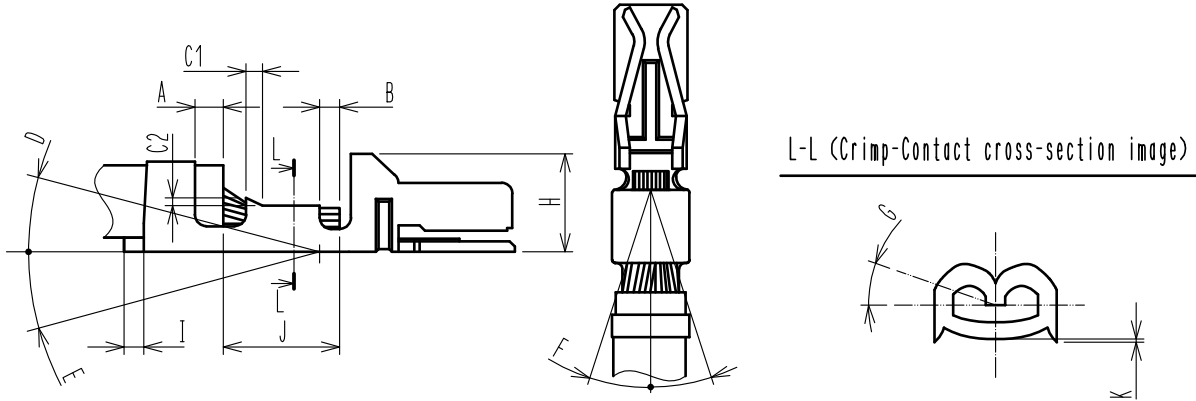

CHECK POINT	MEASURE (mm)	REMARKS
COVER LOCATION. A	0.2-0.7	
LOCATION OF TIP OF THE CORE. B	0.2-0.5	
BELL-MOUTH.	C1	2
	C2	0.05-0.2
BENT-UP. D	2° MAX	
BENT-DOWN. E	3° MAX	
TWIST. F	± 2° MAX	
ROLLING. G	± 5° MAX	
HEIGHT OF RANCE. H	1.8-1.9	
CUT-OFF TAB. I	0.1 MAX	
STRIP LENGTH. J	1.7-2.3	
HEIGHT OF METAL CUT-OUT TEETH. K	0.1 MAX	

NOTE 1 TO ADJUST APPLICATOR, PLEASE CHECK THE CRIMPING CONDITION (CRIMPING HEIGHT AND CONFIGURATION) BY USING CABLE.

- 2 DF11#-22SC\*\*(%) . . . 0.1-0.2
- DF11#-2428SC\*\*(%) . . . 0.1-0.3
- DF11#-30SC\*\*(%) . . . 0.1-0.3

COUNT	DESCRIPTION OF REVISIONS	DESIGNED	CHECKED	DATE
△				
TITLE		<b>HIROSE ELECTRIC CO., LTD.</b> APPROVED HS. OKAWA 18.08.02 CHECKED SZ. ONO 18.08.02 CHARGED TS. MIYAKI 18.08.02 WRITTEN TS. MIYAKI 18.08.02		
DF11#-****SC**(%)				
Crimp Quality Standard				
TECHNICAL SPECIFICATION				
		ETAD-H0773-00	△	1/1