

1.Scope

This document specifies the procedures of mating/unmating operation for DF51 series.

This document contains general guidelines and operating suggestions to use this part safely. Unexpected troubles such as connector breakage could happen, if this product is used in other ways. Please read through this document and understand proper operation before use.

2.Connectors

Part No.	Description
DF51-*P(DP)-2DS(A)	Header
DF51-*EP(DEP)-2C	Plug for relay connection
DF51B-*EP-2A	Branch adapter
DF51-*S(DS)-2C	Crimp socket
DF51-####SC(F)A	Crimp contact for socket
DF51-####PC(F)A	Crimp contact for relay connection plug

△

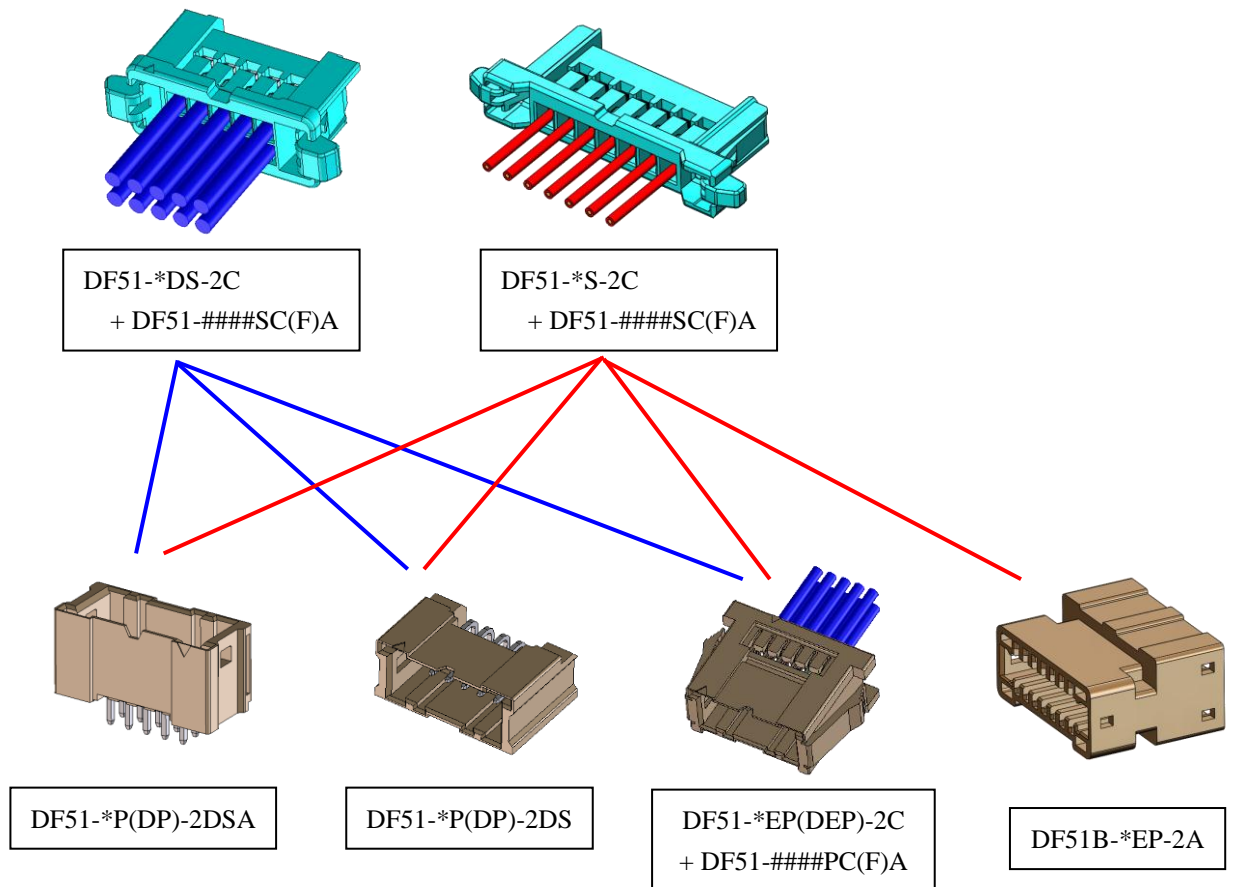

△ Fig. 1: DF51 series

COUNT	DESCRIPTION OF REVISIONS	DESIGNED	CHECKED	DATE
2	DIS-H-00018663	KT.NUMATA	TT.OHSAKO	20230721
TITLE			HRS HIROSE ELECTRIC CO., LTD.	
DF51 Series Mating/Unmating Operation Instruction Manual			APPROVED	KI.AKIYAMA 20160113
			CHECKED	YN.TAKASHITA 20160113
			DESIGNED	TT.OHSAKO 20160113
			WRITTEN	TT.OHSAKO 20160113
TECHNICAL SPECIFICATION			ETAD-H0847-00	△ 1 / 4

3.Operation Procedure

3-1. Mating

3-1-a. Positioning for Insertion

: Position the crimp socket with the header or plug for relay connection according to the mating point mark.

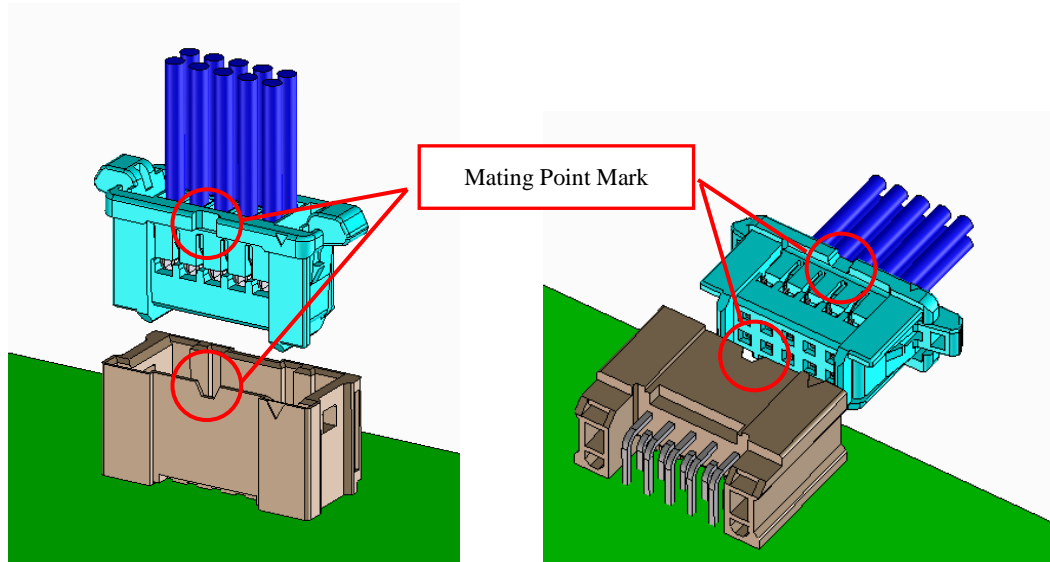

Fig 2. Positioning for Insertion

3-1-b. Insertion and Mating

: Insert the connector until it clicks.

* Please do not press the latches while insertion.

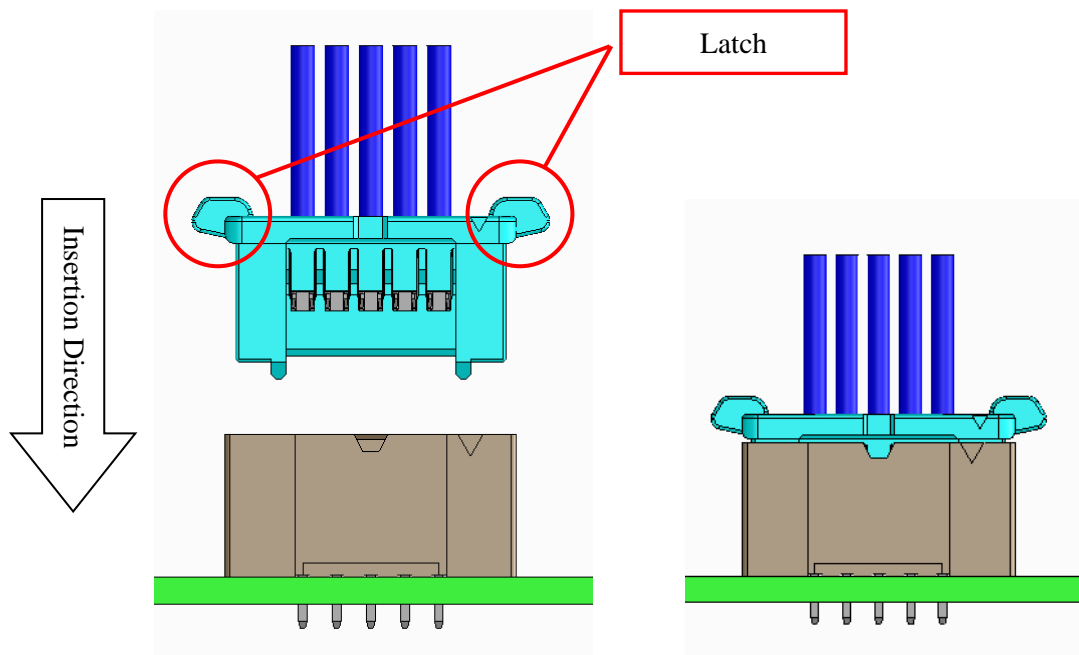

Fig 3. Insertion and Mating

Notice 1 : Do not tilt the socket in insertion as shown below in order to avoid negative influence on quality.

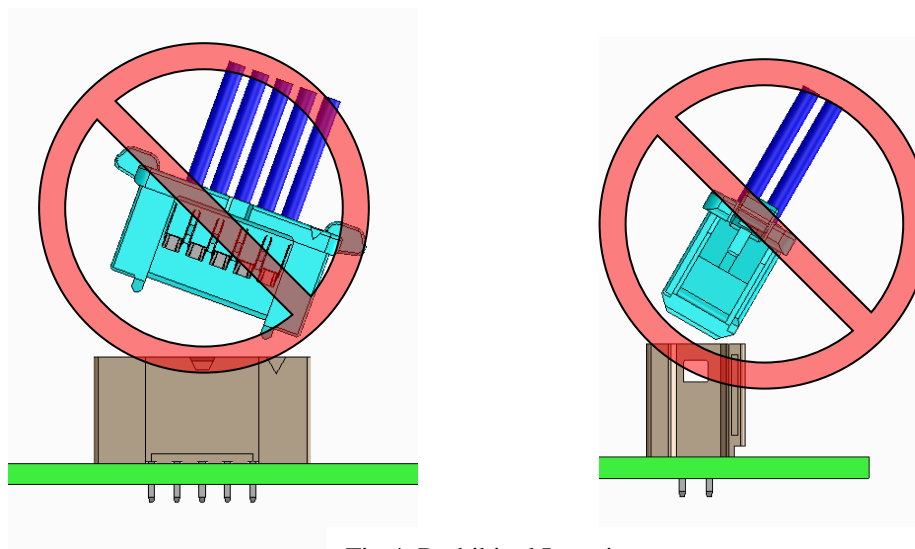

Fig 4. Prohibited Insertion

3-1-c. Confirmation of Mating

: Make sure that the crimp socket is completely mated.

(Make sure if the hooks are caught or not either by looking or by slightly pulling the cables by hand)

See 3-2. Unmating for removal

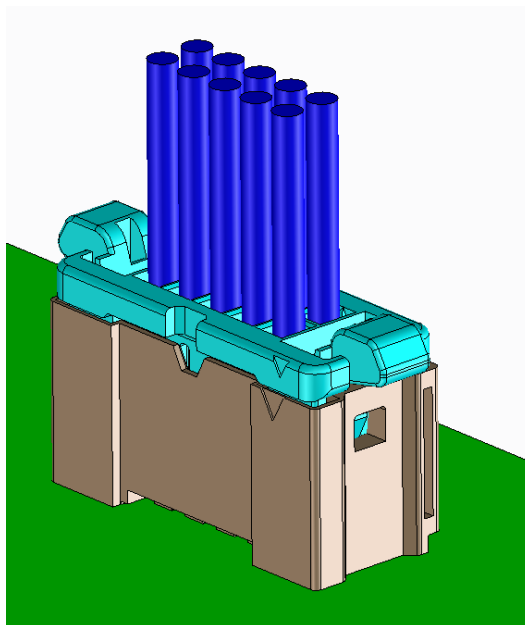

Fig 5. Mating Condition

3-2. Unmating

3-2-a. Grabbing cables

: Grab and hold all cables firmly



Fig 6. Grabbing Cables Condition

3-2-b. Removal

While having the cables, unlock the hooks by pressing the latches and pull the connector vertically

Note: the appropriate unmating cannot be done if the hooks are still stuck.

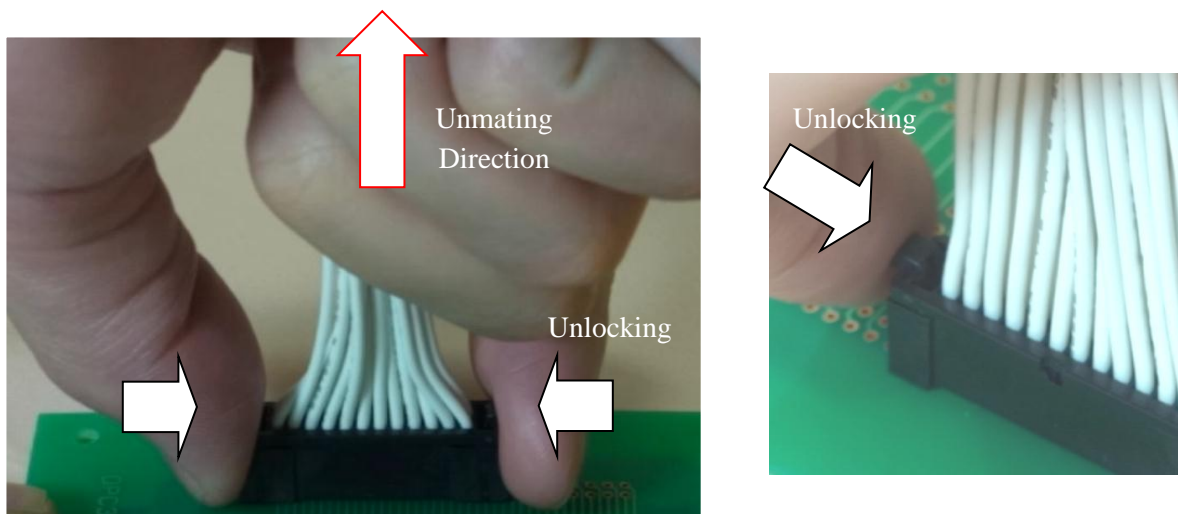

Fig 7. The way of Unmating

4.Precautions

- Do not insert or remove the socket while electrifying.
- Excessive external force to the connectors could cause fault and/or damage.
Therefore, avoid forced mating/unmating, impact given by dropping, or forced pulling the cables.